Vibration Mechanics

A Practical Introduction for Mechanical,
Civil, and Aerospace Engineers



Austin R.J. Downey

Department of Mechanical Engineering
Department of Civil and Environmental Engineering
University of South Carolina, Columbia SC, USA

Laura Micheli

Department of Civil and Environmental Engineering
University of South Carolina, Columbia SC, USA

June 25, 2024

Contents

Preface	iv
Cover Art	iv
License	v
Source Code	v
Questions and Contact Information	v
I Foundational Concepts	1
1 Basic Concepts in Vibrations	2
1.1 Single Degree-of-Freedom Systems	3
1.1.1 Spring-Mass Model	4
1.1.2 Linear Springs	5
1.1.3 Linear Point-mass Models	5
1.2 Equivalent Stiffness	8
1.2.1 Equivalent Stiffness of Structural Systems	9
1.2.2 Springs in Series and Parallel	11
1.3 Equation of Motion for an Oscillating System	14
2 Free Vibrations	20
2.1 Mathematical Modeling of Free Vibration	21
2.1.1 Solve for the Natural Frequency (ω_n) of the System	22
2.1.2 Solve for Initial Phase (ϕ) of the System	23
2.1.3 Solve for Amplitude (A) of the System	24
2.1.4 Response for Simple Harmonic Motion	24
2.1.5 Special Considerations for No Initial Velocity ($v_0 = 0$)	25
2.2 General Solution for Vibrating Systems	28
2.2.1 Formulating the General Solution for a 1-DOF Spring-Mass System	31
2.2.2 Solution of 1-DOF System in Three Forms	34
2.3 Damping	35
2.3.1 Damping Cases	36
2.3.2 Modeling Systems with Damping	37
2.3.3 Modeling Underdamped Motion	39
2.3.4 Modeling Overdamped Motion	46
2.3.5 Modeling Critically Damped Motion	47
2.3.6 Standard Form of the EOM	48
2.4 Logarithmic Decrement	51
3 Forced Vibrations	55
3.1 Harmonic Excitations of Undamped Systems	56
3.2 Harmonic Resonance	59
3.3 Harmonic Excitations of Underdamped Systems	65
3.4 Frequency Response of Underdamped Systems	71

3.5	Base Excitation	75
3.5.1	Displacement Transmissibility Solution for Base Excitation	79
3.5.2	Force Transmissibility Solution for Base Excitation	82
3.6	Numerical Methods	87
4	Transfer Function Approach	90
4.1	Transfer Function Method (Generic)	90
4.2	Transfer Function Method for Solving Vibrating Systems	92
4.2.1	Free Vibration for Undamped Systems	92
4.2.2	Impulse Response Function	94
4.2.3	Unit Step function	96
4.2.4	Undamped Spring-mass System	96
4.2.5	Under Damped Spring-mass System	97
4.3	System Response to Arbitrary Inputs	100
4.4	Transfer Function for Response to Random Inputs	104
4.4.1	Defining the Transfer Function $\mathbf{H}(s)$	104
4.4.2	Transfer Function Method (Steady-state Solution)	105
4.4.3	Response to Random Inputs	110
5	Multiple Degree-of-freedom Systems	117
5.1	General Discussion on Mode Shapes	118
5.2	Modeling Undamped Two- Degree-of-Freedom Systems	119
5.2.1	Solution for Two-Degree-of-Freedom Systems	120
5.2.2	Deriving the Solution for Two-Degree-of-Freedom Systems	121
5.3	Explicit method for Solving 2-DOF Systems	131
5.4	Eigenvalue-based Solution for Natural Frequencies and Mode Shapes	134
5.4.1	Deriving the Eigenvalue-based Solution	135
5.5	Transfer-function Method	142
5.6	Multiple Degrees of Freedom	144
5.7	Modal Analysis	147
5.8	Numerical Methods	154
II	Applied Topics	157
6	Vibration Control	158
6.1	Vibration Nomograph	158
6.2	Vibration Isolation	160
6.3	Vibration Absorption	161
6.3.1	Vibration Absorption for Undamped Systems	162
6.3.2	Vibration Absorption for Damped Systems	164
6.4	Active Vibration Suppression	167
6.4.1	Metrics for Vibration Control	167
6.4.2	Position-Derivative (PD) Control	167
6.4.3	Proportional-Integral-Derivative (PID) Control	169

7	Experimental Vibrations	171
7.1	Sensing and Data Acquisition	172
7.1.1	Accelerometers	172
7.1.2	Data Acquisition	174
7.2	Controlled Force Excitation	175
7.2.1	Modal Hammers	175
7.2.2	Electrodynamic Shakers	176
7.3	Digital Signal Processing	176
7.3.1	Sampling and Quantization	176
7.3.2	Aliasing	178
7.3.3	Time-Frequency Analysis	179
8	Structural Dynamics	180
8.1	Single-story frame	180
8.2	Duhamel's Integral	183
8.3	Two-story frame	186

Preface

This open-source text is designed to offer a complete introduction to the field of vibrations, specifically tailored for undergraduate students. It covers the fundamental principles of vibrations, including single and multi-degree freedom systems, transfer function approaches, and vibration control, along with measurement and instrumentation. Each chapter includes examples and case studies to reinforce the concepts presented. With its simple and clear explanations and practical approach, this textbook serves as a resource for undergraduate students studying vibrations in engineering disciplines.

Cover Art

The B-57 Canberra is an American-built copy of the British English Electric Canberra which first flew in 1949. During initial high-speed flight testing, excessive vibrations were measured on the canopy and a small fairing was added behind the canopy to reduce the aerodynamic load on the canopy and thereby reduce the vibrations. Overall, airframe flight testing is said to have gone very smoothly.

The B-57 was initially a twin-engined tactical bomber and reconnaissance aircraft but over the years, various versions were produced or modified from the original stock. These include the WB-57F, a specialized strategic reconnaissance version developed for the U.S. Air Force that is still flown by NASA for scientific missions. Of note, in 2011 NASA determined that they needed a third WB-57F to support their mission, and an additional WB-57 (s/n 63-13298) was removed from the Air Forces Boneyard in Tucson Arizona after 40 years of storage and returned to operational status. As of 2022, three airframes are still flying for NASA.

The airframe on the cover is the SN 52-1516 and is an EB-57B “Night Intruder” which is an electronic countermeasure (ECM) version of the B-57 and is on static display at the Air Force Armament Museum at Eglin Air Force Base, Florida.

License

This work is licensed under a Creative Commons Attribution-ShareAlike 4.0 (CC BY-SA 4.0) International License. More information on the CC BY-SA 4.0 license can be found at <https://creativecommons.org/licenses/by-sa/4.0/>. Unless otherwise denoted, all text, figures, diagrams, and photos used in this work are the sole property of the authors and are released under CC BY-SA 4.0 both in part or in whole. Reworks and redistributions of this work that fall within the CC BY-SA 4.0 licenses are encouraged.

Source Code

Source material is available at <https://github.com/austindowney/Vibration-Mechanics>.

Questions and Contact Information

For questions, corrections, or requests, contact Austin Downey at austindowney@sc.edu.

Part I

Foundational Concepts



The Arthur Ravenel Jr. Bridge spans the Cooper River outside of Charleston South Carolina (USA) with a main span of 471 m (1,546 feet) and uses dampers on the center cables to mitigate wind and traffic-induced vibrations in the structure. It is the third longest among cable-stayed bridges in the Western Hemisphere (2023).

1 Basic Concepts in Vibrations

Vibrations, within the broader field of classical mechanics, is the investigation of oscillations that occur about an equilibrium point. Vibrations, both desired and undesired, are present in all mechanical systems and can be helpful (e.g. a soil sieve, rotary sander) or destructive (e.g. an aircraft frame in resonance). The oscillations that form a vibrating system may be periodic (e.g., pendulum) or random (e.g. turbulence in an airplane), or a combination of the two.

Vibrations impact our daily lives in a variety of ways, from the sound made by banjo strings that vibrate between 140 and 400 Hz to the vibrations felt by a passenger in a car seat that are typically under 6 Hz.

The consideration of vibrations, and their associated mathematical modeling, are important factors in the design of mechanical systems. In this text, the fundamental theories of vibration are presented and modeled using basic physical principles such as Newton's three laws of motion. These models and analyzed using the mathematical tools of calculus and differential equations.

Vibration Case Study 1.1 TSR-2 and the Resonance of the Human Eye

Why study vibrations? One day, it could save your life! The British Aircraft Corporation (BAC) TSR-2 (figure 1.1) was a strike and reconnaissance aircraft developed during the Cold War by BAC, for the Royal Air Force (RAF). During the second flight test of airframe XR219, vibration from one of the plane's fuel pumps caused vibration at the resonant frequency of the human eyeball. As you may expect, a human eye experiencing high levels of vibrations will distort, causing blindness. Test pilot Roland Beamont was blinded by the vibrations that originated in the fuel pump and transmitted to his head. Roland just happened to be an expert in vibrations and had the knowledge to throttle back one engine. This led to a reduction in the vibrations and a restoration of his full vision.



Figure 1.1: The only BAC TSR-2 prototype to fly, picture taken in 1966 at what is now BAE Warton Lancashire.^a

Roland gained his expertise in vibrations during WW II. During this time he led the vibration program of the Hawker Typhoon. He fit vibrographs to airplanes to determine the effectiveness of propeller balancing. He also led the testing testing of seats with vibration isolators to limit vibrations transmitted from the airframe into the pilot.

^aRuthAS, CC BY 3.0 <<https://creativecommons.org/licenses/by/3.0/>>, via Wikimedia Commons

Review 1.1 Newton's Laws of Motion

Newton's three laws of motion:

1. In an inertial frame of reference, an object either remains at rest or continues to move at a constant velocity unless acted upon by a force.
2. In an inertial reference frame, the vector sum of the forces F on an object is equal to the mass m of that object multiplied by the acceleration of the object: $F = ma$. (It is assumed here that the mass m is constant)
3. When one body exerts a force on a second body, the second body simultaneously exerts a force equal in magnitude and opposite in direction on the first body.

1.1 Single Degree-of-Freedom Systems

In its simplest form, the phenomenon of vibration is the exchange of energy between potential and kinetic energy. Therefore, a vibrating system must have a component that stores potential energy. This component must also be capable of releasing the energy as kinetic energy. This kinetic energy is stored in the movement of a mass where the measure of this movement is the velocity of the system. The continuous interchange between potential and kinetic energy is the vibration of the system. The simplest vibrating systems can be modeled as a single-degree-of-freedom (1-DOF) system. In a 1-DOF system, one variable can describe the motion of a system. Potential examples of 1-DOF systems include:

- yo-yo
- pogo stick
- door swinging on axis
- throttle (gas pedal)

Variables often used for describing 1-DOF systems are $x(t)$, $y(t)$, $z(t)$, and $\theta(t)$. Examples of 1-DOF systems are presented in figure 1.2 where the assumption of small displacements is made.

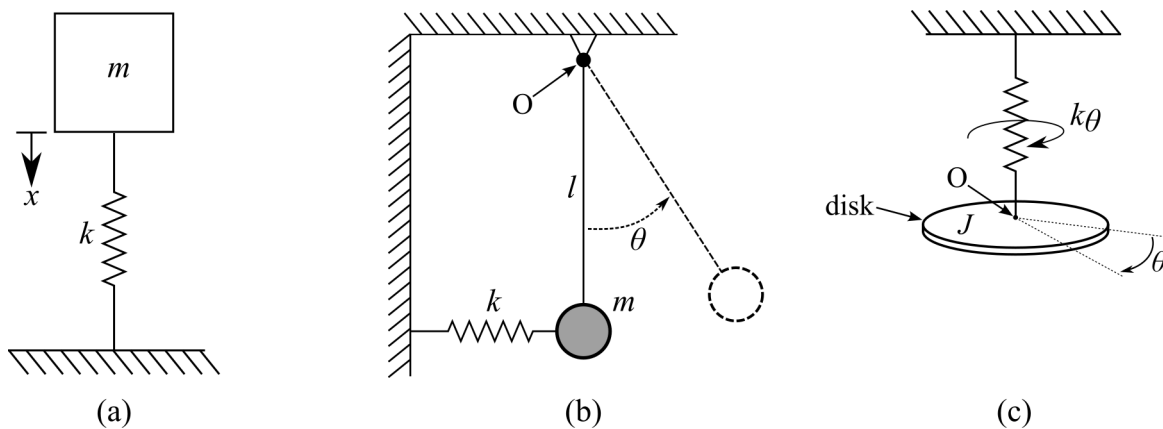

Figure 1.2: Examples of single degree of freedom (DOF) systems showing: (a) a vertical spring-mass system; (b) a simple pendulum; and (c) a rotational spring-mass system.

NOTE

We will often drop the “(t)” for simplicity in this text, such that x , y , z , and θ become the notation for the variables of interests

1.1.1 Spring-Mass Model

Newtonian physics describes the motion of particles in terms of displacement x , velocity \dot{x} , and acceleration \ddot{x} vectors. Moreover, Newton’s second law of motion says that the change in the velocity of mass in motion is a product of the force acting on the mass. A simple way to express this phenomenon is through a spring-mass model as presented in figure 1.3. These spring-mass models neglect the mass of the spring and concentrate all the mass of the system into a single point. Note that in this case the force vector and mass-acceleration vectors lie on the same axis and as such are collinear. Therefore, these vectors can be easily treated as scalars simplifying the math used in the modeling of the system.

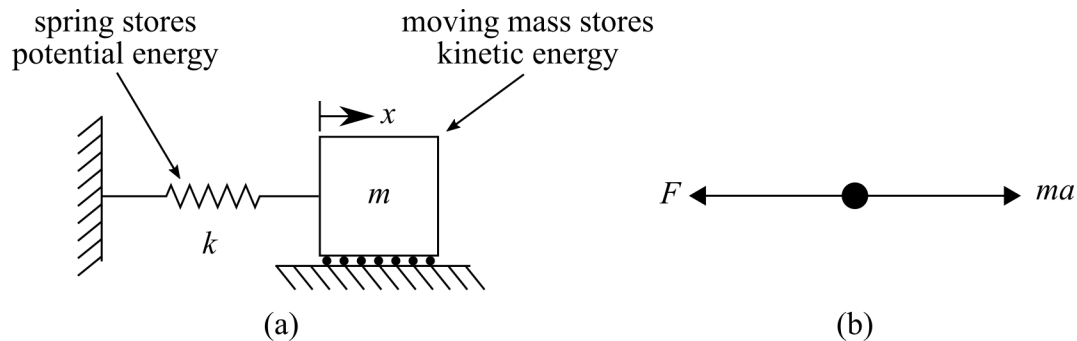

Figure 1.3: A single-degree-of-freedom (1-DOF) spring-mass model showing: (a) annotated schematic of a mass-spring system; and (b) the equivalent free-body diagram represented as a point-mass system.

Review 1.2 Assumption of Small Displacements

The assumption of small displacements states that any displacement in a system is considerably smaller than the initial geometry of the system. This means that any 2nd-order effects caused by displacements within the system are ignored. These 2nd-order effects could be loads or angles at the point of linkage/spring connections.

1.1.2 Linear Springs

Springs are mechanical devices that store energy, moreover, an ideal spring is a theoretical representation of this mechanical device that is massless and responds with a linear increase in force for a unit increase in displacement (i.e. $F = kx$). For simplicity, the springs in the spring-mass models considered in this text are always assumed to be ideal linear springs. A graphical representation of the idealized linear spring is presented in figure 1.4 where a unit force F applied to the free end of the spring results in a unit displacement x of the spring. The resulting mathematical relationship, $F = kx$, is known as Hooke's Law. Nonlinear springs add considerable complexity to the modeling of spring-mass systems, therefore, these are not considered in this introductory work.

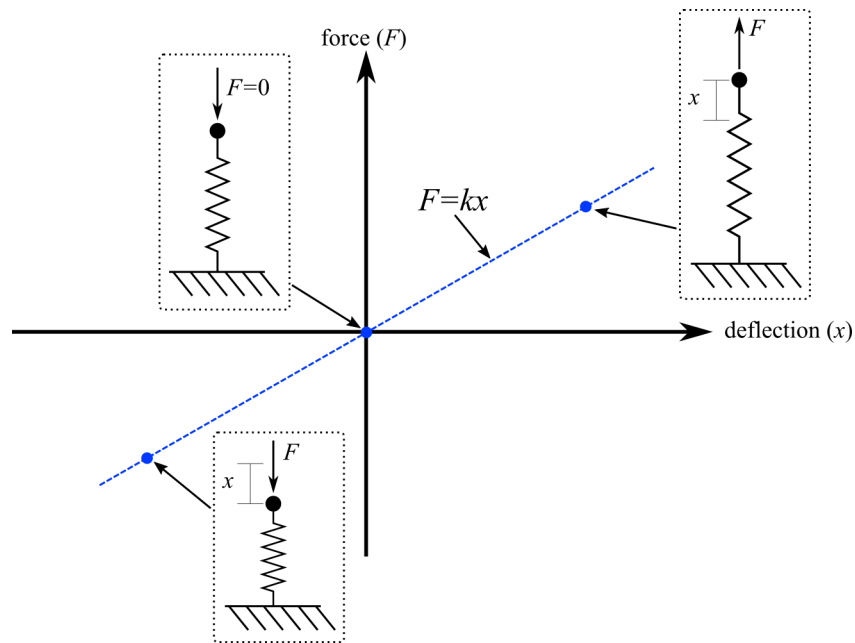

Figure 1.4: Force-displacement plot for a linear spring.

1.1.3 Linear Point-mass Models

Combining linear springs and point masses we get *linear point-mass models*; to which we will add dampers in Chapter 2. An important thing to consider is that the linear point-mass models used throughout this text are only a representation of real-world systems. Moreover, this representation removes any concept of non-linearity that is always present in physical systems. While these models are a gross under-representation of how a system would oscillate in the real world; they can capture enough of the system's dynamics to be incredibly useful in engineering and design. leading to the famous quote:

“All models are wrong, but some are useful”

George E.P. Box (1919 - 2013)

Vibration Case Study 1.2 Adjustable Vehicle Suspension

Why study vibrations? Because vibrations form an integral part of how we interact with our world and as such, are an important consideration in product. For example, vibrations in the automotive industry fall within a field of expertise termed Noise Vibration and Harshness (NVH). NVH is important because, within a single company, different levels of NVH will be desired for different market segments and products.

With a proper understanding of NVH, engineers can design cars that can adapt to their environment or desired use case. Consider the 2019 VW Golf GTI shown in figure 1.5(a) equipped with a dynamic suspension system where the driver can select between ‘comfort’ ‘normal’ and ‘sport’ suspension options. To investigate the effect of these suspension settings, an engineer can install an accelerometer (a sensor used for measuring acceleration) as shown in figure 1.5(b). An important consideration in measuring acceleration is where and how to mount the accelerometer. Here, the accelerometer is mounted in the cup holder to measure the vertical acceleration in the center of the car.

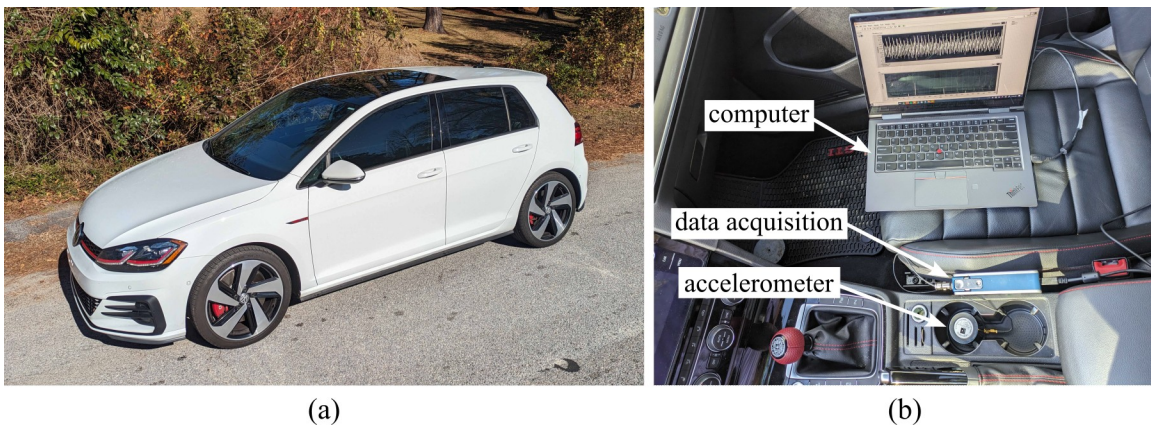

Figure 1.5: VW Golf GTI with three suspension modes, showing: (a) the car, and; (b) the accelerometer and data acquisition system used for measuring vibrations.

Figure 1.6 shows the measured acceleration in both the time and frequency domains for the three suspension modes during 5 minutes of interstate driving. Note that in the time domain, the responses of the three suspension modes are indistinguishable. However, in the frequency domain, the sport mode is shown to have greater vibrational energy. Later in this text we will delve into the technical aspects of power spectral density, for now, consider the area under the curve to be representative of the measured energy for each suspension setting.

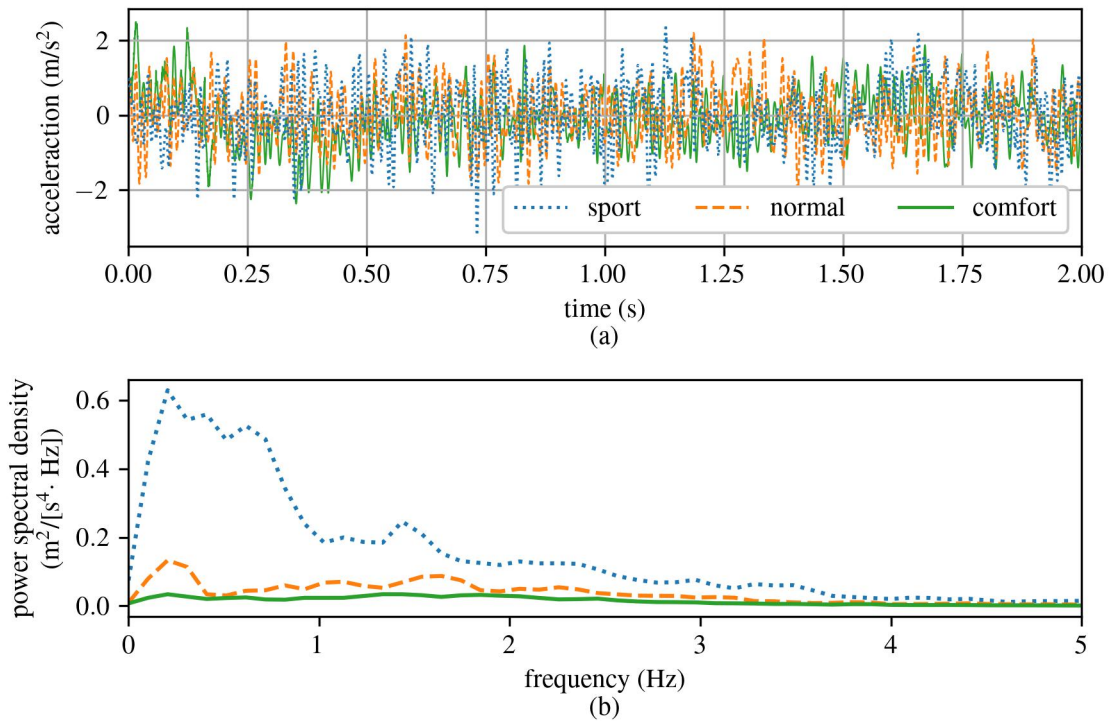

Figure 1.6: Response measured using the experimental setup shown in figure 1.5(b), showing (a) time-series data, and b) spectrum in the frequency domain.

The sport mode is by far the suspension mode with the firmest ride and the highest amount of measured vibration energy. While a stiff ride is beneficial during spirited driving on a track, the associated NVH level is tiring during prolonged driving. However, the comfort mode adds a considerable amount of damping to the suspension, resulting in a ride quality that is much more amenable to everyday driving. An engineer, using their knowledge of vibrations, could develop systems that enable a single product (such as an automobile or an airplane) to function well in multiple use cases; thereby increasing its usefulness and marketability.

1.2 Equivalent Stiffness

The generalized concept of stiffness can be directly related to mechanical systems and structural components through Hooke's law.

Review 1.3 Hooke's Law

Hooke's Law states that the force (F) needed to extend or compress a spring by some distance x scales linearly with respect to that distance. This law can be extended to the tensional stress of a uniform and elastic bar where the length, area, and Young's modulus of the bar are represented by l , A , and E , respectively. Knowing the tensile stress in the bar:

$$\sigma = \frac{F}{A} \quad (1.1)$$

and the definition of strain:

$$\varepsilon = \frac{\Delta l}{l} \quad (1.2)$$

Hooke's law can be expanded to represent a uniform and elastic bar:

$$\sigma = E\varepsilon \quad (1.3)$$

It follows that the change in length Δl can be expressed as:

$$\Delta l = \varepsilon l = \frac{Fl}{AE} \quad (1.4)$$

Hooke's law is often expressed using the convention that F is the restoring force exerted by the spring on the applied force at the free end. Defining the stiffness and displacement as $k = \frac{AE}{l}$ and $\Delta l = x$, respectively. The equation for Hooke's Law becomes:

$$F = -kx \quad (1.5)$$

since the direction of the restoring force is opposite the spring displacement.

1.2.1 Equivalent Stiffness of Structural Systems

For a rod with a uniform cross-section, a direct representation of the system can be developed as expressed in figure 1.7 where the vibration along the axis of the rod is to be considered. The stiffness of the rod, k , is a measure of the resistance offered by an elastic body to deformation.

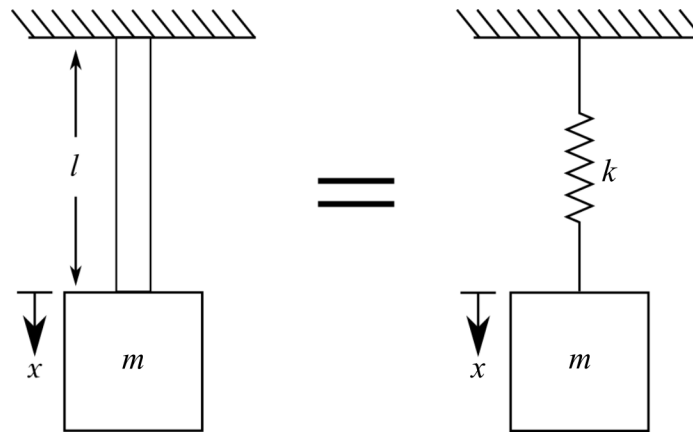

Figure 1.7: Equivalency between a vertical bar with a mass attached to the bottom and a spring-mass model of the system.

For this 1-DOF system, the equation of a spring can be rearranged such that the stiffness can be defined as:

$$k = \frac{F}{x} \quad (1.6)$$

The stiffness of the spring can be more closely related to material properties of the bar A , E , and l considering that Hooke's Law for the uniform tension on a bar can be expressed as:

$$\sigma = E\varepsilon \quad (1.7)$$

This expression can be expanded into the form:

$$\frac{F}{A} = E\left(\frac{x}{l}\right) \quad (1.8)$$

rearranging the terms and recalling the expression $k = \frac{F}{x}$ leads to:

$$k = \frac{EA}{l} \quad (1.9)$$

In a similar fashion, we can also solve the equivalent system for a mass at the end of a cantilever beam (figure 1.8).

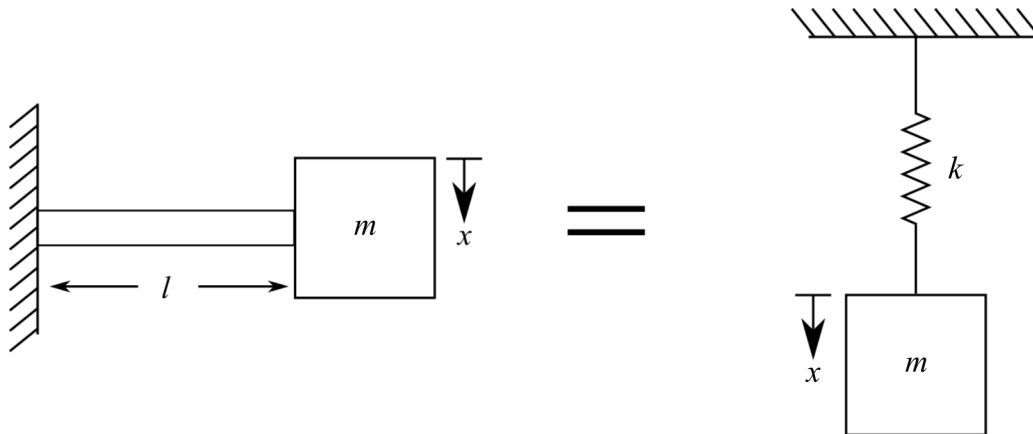

Figure 1.8: Equivalency between a cantilever beam and a spring mass system.

From engineering mechanics, we can compute the deflection at the point of a beam δ with a point load P . This expression is typically expressed as:

$$\delta = \frac{Pl^3}{3EI} \quad (1.10)$$

If we transform this equation into our variable system by exchanging P for F and δ for x . Thereafter, the point load is replaced with the equivalent force F generated by the mass and the pull of gravity (mg). As before, knowing that the stiffness of the system can be expressed as $k = F/x$ we can show that:

$$k = \frac{3EI}{l^3} \quad (1.11)$$

Example 1.1 Axial Rod Vibrations

Considering the rod diagrammed below; calculate an equivalent spring constant for the rod using the length of the rod l , its area A , and Young's modulus E for a compressive force F that compresses the rod a distance x . Additionally, is a linear spring a useful model for a rod under compression? What if the rod is under tension?

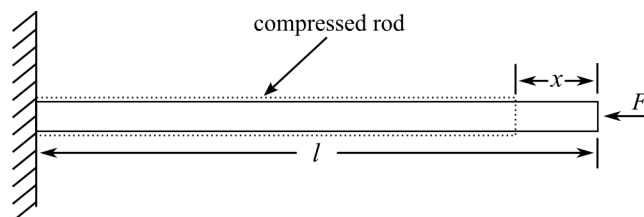

Figure 1.9: Compressed cantilever rod.

Solution:

The rod shortens by a distance x under the axial force F , this can be related to the equation of a linear spring $F = kx$ by recalling from solid mechanics that the elongation (or shortening) of a rod is expressed as

$$x = \frac{x}{l}l = \epsilon l = \frac{\sigma}{E}l = \frac{Fl}{AE} \quad (1.12)$$

where $\epsilon = \frac{x}{l}$ is the strain value and $\sigma = F/A$ is the stress induced in the rod. Combining this expression with the equation of a linear spring yields:

$$k = \frac{F}{x} = \frac{AE}{l} \quad (1.13)$$

As per the usefulness of the linear spring to represent an axial rod under compression or tension, this would be application-specific but could generally be considered an excellent first-order approximation.

1.2.2 Springs in Series and Parallel

In many cases, it becomes necessary to model a mechanical system as a set of springs (e.g., a composite material, a table with multiple legs). For these systems, or for systems with more than one spring acting on a body, equivalent stiffness can be calculated as:

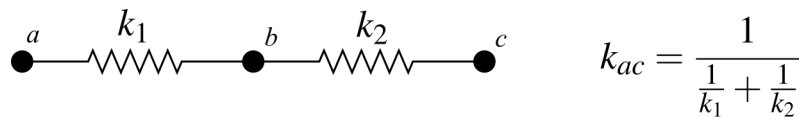

(a)

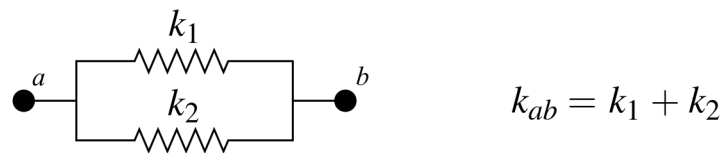

(b)

Figure 1.10: Equations for calculating the equivalent stiffness of two springs (k_1 and k_2); (a) in series; and (b) in parallel.

These are derived considering the displacement δ of the systems. For two springs in series:

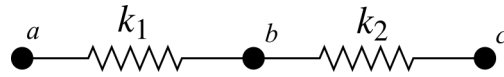

Figure 1.11: Two springs k_1 and k_2 combined in series.

where the total displacement is

$$\delta_{ac} = \delta_{ab} + \delta_{bc} \quad (1.14)$$

Using the equation for stiffness $k = F/\delta$, this converts to:

$$\frac{F}{k_{ac}} = \frac{F}{k_1} + \frac{F}{k_2} \quad (1.15)$$

As F is the same throughout the system, we can cancel out F . Solving for the equivalent stiffness yields:

$$k_{ac} = \frac{1}{\frac{1}{k_1} + \frac{1}{k_2}} \quad (1.16)$$

Similarly for a system of springs in parallel:

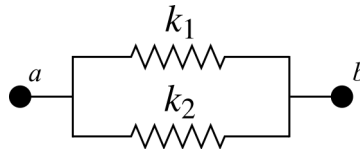

Figure 1.12: Two springs k_1 and k_2 combined in parallel.

The displacement in both springs is the same, so the total displacement is

$$\delta_{ab} = \delta_1 = \delta_2 = \delta \quad (1.17)$$

The forces in the direction of spring elongation sum to zero, therefore:

$$F_{ab} = F_1 + F_2 \quad (1.18)$$

Substituting the displacement and stiffness into the force equation yields:

$$\delta k_{ab} = \delta k_1 + \delta k_2 \quad (1.19)$$

this simplifies to:

$$k_{ab} = k_1 + k_2 \quad (1.20)$$

Example 1.2 Springs in Parallel and Series Configurations

Calculate the equivalent stiffness of the following system:

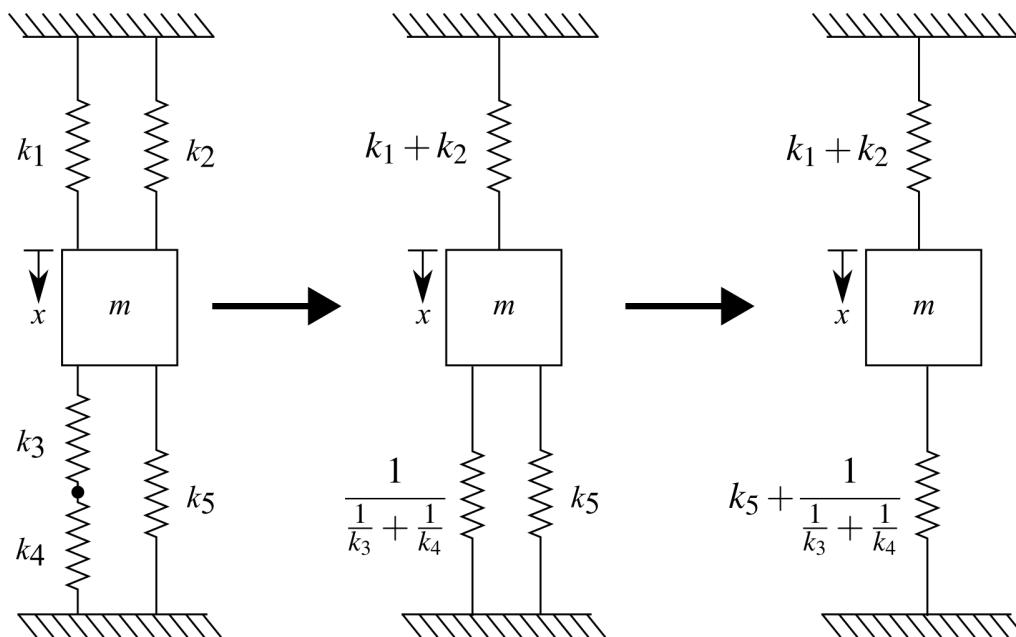

Figure 1.13: Equivalent stiffness for springs in series and parallel.

The springs are combined as shown, using the equations defined before. Now, considering that the displacement (δ) of the top spring, and the bottom spring are the same we can state the total stiffness k , which is the summation of the two. Therefore,

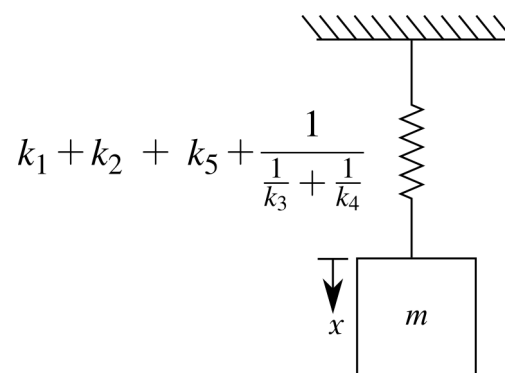

Figure 1.14: A spring-mass system simplified down from springs in series and parallel..

where the final addition, $(k_1 + k_2) + (k_5 + \frac{1}{\frac{1}{k_3} + \frac{1}{k_4}})$ is applied at two springs in parallel as each spring is connected between the mass and the fixity. Rearranging this new expression to get a common denominator:

$$k = \frac{(k_1 + k_2 + k_5)(k_3 + k_4) + k_3 k_4}{k_3 + k_4} \tag{1.21}$$

1.3 Equation of Motion for an Oscillating System

An Equation of Motion (EOM) is an equation that provides a basis for modeling a vibrating system about its equilibrium point and relates the transfer of the potential energy from the spring to the kinetic energy mass. In developing the EOM we assume that any surfaces are frictionless and as such, no energy is extracted from the vibrating system. Referencing the 1-DOF system in figure 1.15(a), and assuming the mass only moves in the x direction, the only force acting on the mass in the x direction is the force that results from the elongation of the spring as annotated in figure 1.15(b). Therefore, the sum of forces along the x axis must equal the mass (m) times the acceleration of the mass ($a\ddot{x}$).

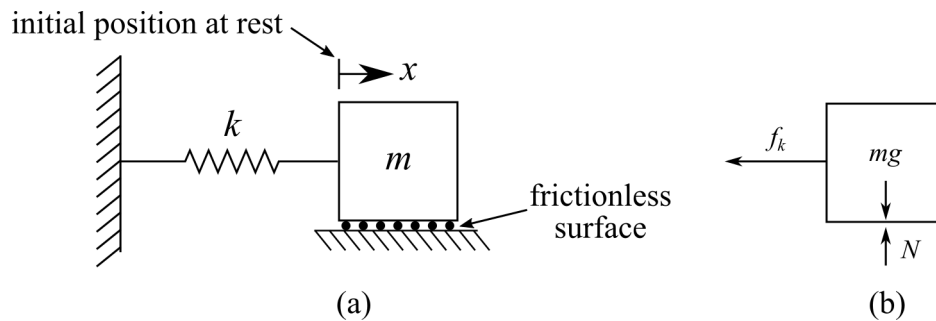

Figure 1.15: A spring-mass model of a 1-DOF system showing: (a) a schematic of the system; (b) a free-body diagram of the system at its initial position.

Considering that positive displacements are to the right, the standard form of the equation of motion for an undamped system without any excitation is expressed as:

$$s_1\ddot{x} + s_2x = 0 \quad (1.22)$$

where s_1 and s_2 are constants to be determined for the specific system. A systematic approach to obtaining the free-body diagram (FBD) of a system under vibration can be expressed in three steps:

1. Draw a free-body diagram (FBD) at the system's equilibrium and displaced position (without a displacing force).
2. Apply Newton's second law to both FBDs (equilibrium and displaced).
3. Combine the equations to write the EOM in standard form with the forcing component on the right-hand side. For free vibration, the forcing component is 0.

Solving these three steps for 1-DOF system presented in figure 1.15 results in the EOM:

$$m\ddot{x} + kx = 0 \quad (1.23)$$

Review 1.4 Differential Equation

A second-order linear homogeneous differential equation has the form:

$$a\ddot{x} + b\dot{x} + cx = 0 \quad (1.24)$$

The EOM for a 1-DOF system under a free vibration is a second-order differential equation due to acceleration (\ddot{x}) being the second derivative of displacement (x) and homogeneous as the forcing function (right-hand side of the equations) is zero. In EOM's current form, $a = m$, $b = 0$, and $c = k$. In future work, b will account for damping in the vibrating system.

Example 1.3 Deriving Equation of Motion

Considering the system:

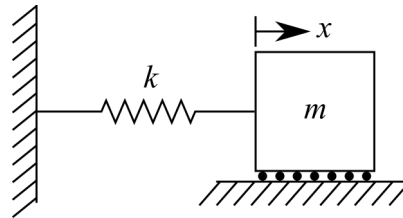

Figure 1.16: A 1 DOF spring-mass system with movement in the horizontal direction

Step-1 Define the direction of displacement, and draw the FBD for the equilibrium and displaced state.

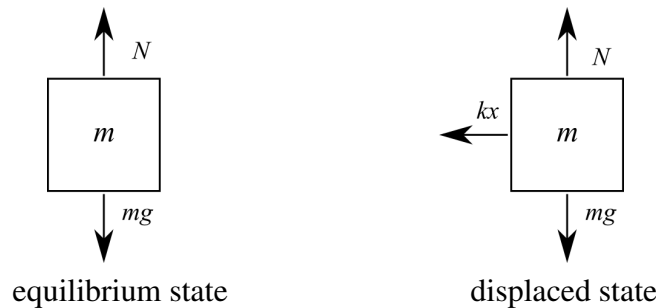

Figure 1.17: Equivalent forces for a 1 DOF spring-mass system with movement in the horizontal direction

The equation for the equilibrium state is:

$$\overset{\pm}{\rightarrow} \sum F_x = 0 \quad (1.25)$$

and in the displaced state:

$$\overset{\pm}{\rightarrow} \sum F_x = -kx \quad (1.26)$$

This equation does not equal zero as the FBD does not account for the restoring force.

Step-2 Apply Newton's second law (we want to store energy in the kinetic state) of motion to the sum of forces for the displaced position we get:

$$ma = m\ddot{x} = \sum_{\rightarrow} F_x = -kx \quad (1.27)$$

$$m\ddot{x} = -kx \quad (1.28)$$

Step-3 Rearrange in the Equation to construct an EOM:

$$m\ddot{x} + kx = 0 \quad (1.29)$$

Vibration Case Study 1.3 Design Considerations in Vibrations

Why study vibrations? One day, it could save your job! For a project to be successful it needs to be completed on time and within budget.

Consider the Ling-Temco-Vought (LTV) XC-142 which was a tilt-wing experimental aircraft developed in the 1960s for the US military and later turned over to NASA. During testing, the cross-linked driveshaft produced excessive vibration and noise which resulted in a high pilot workload. In general, the aircraft's cross-linked driveshaft was the main technical issue that caused the military to lose interest in the project.



Figure 1.18: A Ling-Temco-Vought XC-142A tested at the NASA Langley Research Center in 1969. ^a

^aNASA, Photograph published in Winds of Change, 75th Anniversary NASA publication, by James Schultz, Public domain, via Wikimedia Commons

Example 1.4 Deriving Equation of Motion Considering Initial Displacement

Some systems will have an initial displacement, as the system will oscillate around this position we need to define the EOM about this position. Considering the system:

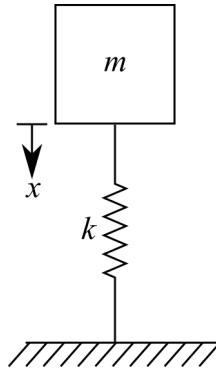

Figure 1.19: A 1 DOF spring-mass system with movement in the vertical direction.

Step-1 Define the direction of displacement (if needed, it is given in this problem) and draw the FBD for the equilibrium and displaced state.

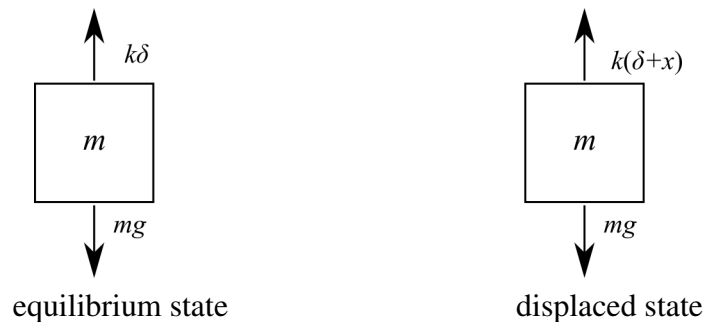

Figure 1.20: Equivalent forces for a 1 DOF spring-mass system with movement in the vertical direction

The equation for the equilibrium state is:

$$+\downarrow \sum F_x = mg - k\delta = 0 \quad (1.30)$$

and in the displaced state:

$$+\downarrow \sum F_x = mg - k(\delta + x) \quad (1.31)$$

This equation does not equal zero as the FBD does not account for the restoring force.

Step-2 Apply Newton's second law (we want to store energy in the kinetic state) of motion to the sum of forces for the displaced position we get:

$$m\ddot{x} = +\downarrow \sum F_x = mg - k\delta - kx \quad (1.32)$$

We can then use the information from the equilibrium state to cancel out some terms, this becomes:

$$m\ddot{x} = -kx \quad (1.33)$$

Step-3 Rearrange in the Equation to construct an EOM:

$$m\ddot{x} + kx = 0 \quad (1.34)$$

Example 1.5 Deriving Equation of Motion Considering Torsional Stiffness

Equations of motion can also be developed for systems with torsional stiffness. Considering the system in figure 1.21 where k is the stiffness in the rotational direction and the shaft is perfectly rigid in the vertical direction. Moreover, consider the polar moment of inertia of the disk (J) that spins about the origin defined as point O.

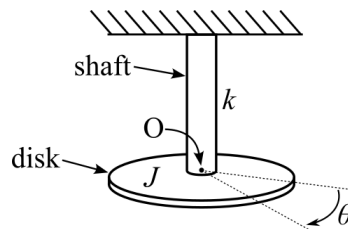

Figure 1.21: A 1 DOF system with a mass-less shaft and a disk where the direction of movement results in a torsional loading of the shaft.

Step-1 Draw the FBD for the equilibrium and displaced state.



Figure 1.22: Equivalent moments for a 1 DOF torsional system.

Considering that $\zeta+$, the equation for the equilibrium state is:

$$\zeta+ \sum M_O = 0 \quad (1.35)$$

as there is no initial displacement due to gravity this expression gives no useful information in this case and is ignored in this example. Next, the displaced state is:

$$\zeta+ \sum M_O = -k\theta \quad (1.36)$$

This equation does not equal zero as the FBD does not account for the restoring force that is present where the shaft connects with the fixity.

Step-2 Apply Newton's 2nd law given the fact that we were given the moment of inertia of a disk as J ,

$$\sum M_O = J\ddot{\theta} = -k\theta \quad (1.37)$$

Step-3 Derive EOM:

$$J\ddot{\theta} + k\theta = 0 \quad (1.38)$$

2 Free Vibrations

Vibrations (i.e. the exchange of potential and kinetic energy) require oscillatory motion that may repeat itself regularly or irregularly. A motion that is repeated at time intervals is called periodic motion. If this motion has a single frequency and amplitude it is called simple harmonic motion. This motion represents the most basic form of oscillatory motion as depicted in figure 2.1. For a 1-DOF system, simple harmonic motion is defined as a periodic motion where the restoring force is directly proportional to the displacement and acts in the direction opposite to that of displacement.

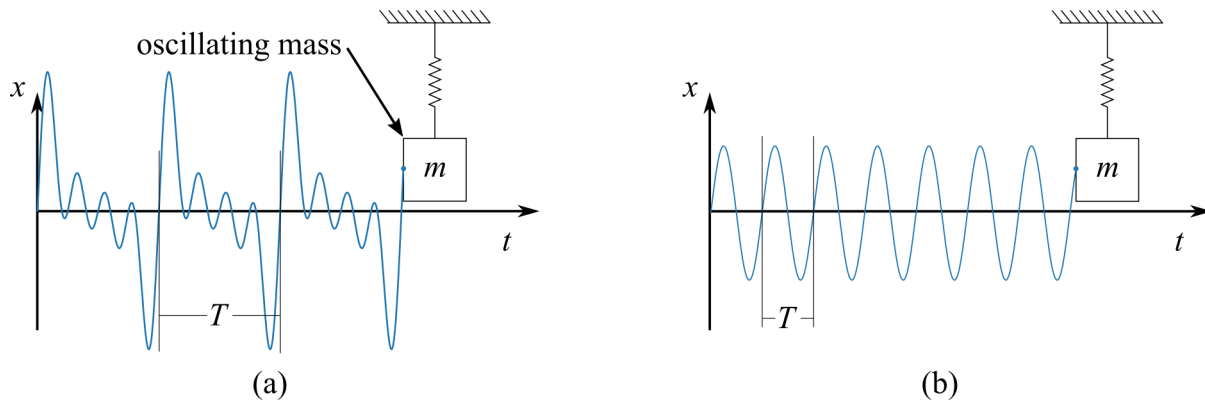

Figure 2.1: Oscillatory motion for a single degree of freedom system showing (a) periodic motion; and (b) simple harmonic motion.

Given the nature of simple harmonic motion, constant amplitude, and frequency, the wave starting at the origin O can be modeled at a point on the end of a vector with length A rotating at a constant angular velocity ω_n where the angle from the origin of the vector is ϕ , defined as $\phi = \omega t$. Where ω is the lowercase Greek letter Omega and ϕ is the lowercase Coptic letter phi. This is similar to a Greek phi (ϕ) and either can be used in this context. The subscript n on ω denotes that this frequency relates to the natural frequency of the system, the only frequency in simple harmonic motion. A visualization of the harmonic motion obtained from projecting the point on the edge of a vector onto the $\omega_n t$ space is presented in figure 2.2.

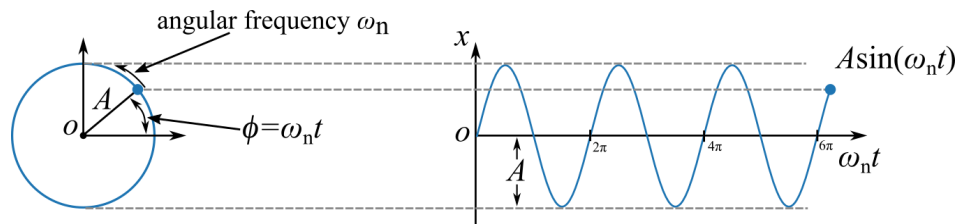

Figure 2.2: Harmonic motion represented as the projection of a point on the end of a vector moving on a circle. Note the axis $\omega_n t$.

2.1 Mathematical Modeling of Free Vibration

The Development of a mathematical model for a system under free vibration would enable the practitioner to predict, or model, the vibrating system of interest. Therefore, considering the following system,

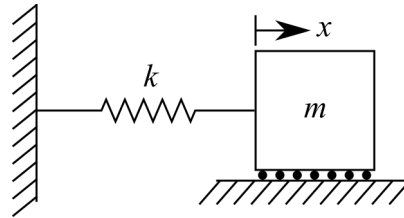

Figure 2.3: 1-DOF spring-mass system.

can be modeled expressed with the following EOM

$$m\ddot{x}(t) + kx(t) = 0 \quad (2.1)$$

it becomes prudent to solve this homogeneous ordinary differential equation (ODE) to obtain a model of the vibrating system.

The simplest method for solving an ODE is to propose a solution based on observations of a vibrating physical system^a. Figure 2.4 reports and annotates the key components from an observation of a vibrating system.

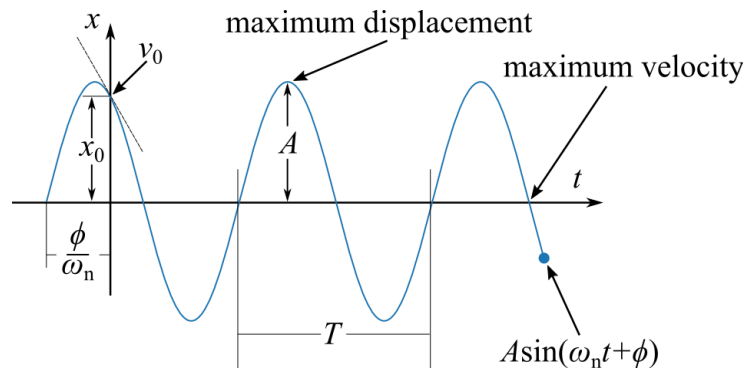

Figure 2.4: Summary of the temporal response for a 1-DOF system.

where x_0 and v_0 are the is the displacement and velocity at $t=0$ (i.e. the initial displacement).

A mathematical expression can now be formulated to represent the observed simple harmonic motion. This expression can be based on the projection of a point on a vector (transposed into the time domain) or assembled from constituent parts as done in what follows. Solving for a location x , at a time t ; $x(t)$, the various characteristics of the expression can be identified:

- System oscillates \rightarrow a sin function models this

^aCalled an ansatz solution. Oxford Languages definition: noun, MATHEMATICS, an assumption about the form of an unknown function which is made in order to facilitate solution of an equation or other problem.

- System oscillates at different speed \rightarrow use a parameter to adjust ω_n in rad/s.
- Systems have different amplitudes \rightarrow use a parameter to adjust A in meters.
- System has different starting points \rightarrow use a parameter to adjust ϕ in rad.

Using these four constituent components, an equation can be proposed:

$$x(t) = A\sin(\omega_n t + \phi) \quad (2.2)$$

This expression can be shown to be the correct solution of a 1-DOF system through simple experimentation.

2.1.1 Solve for the Natural Frequency (ω_n) of the System

Often, we wish to directly compute the natural frequency of a system from its parameters. Take the derivative to get velocity:

$$\dot{x}(t) = A\omega_n \cos(\omega_n t + \phi) \quad (2.3)$$

Take the derivative again to get acceleration:

$$\ddot{x}(t) = -A\omega_n^2 \sin(\omega_n t + \phi) \quad (2.4)$$

Substituting x and \ddot{x} into the EOM for the considered 1-DOF system ($m\ddot{x}(t) + kx(t) = 0$) yields:

$$m(-A\omega_n^2 \sin(\omega_n t + \phi)) + k(A\sin(\omega_n t + \phi)) = 0 \quad (2.5)$$

Thereafter, dividing both sides by $A\sin(\omega_n t + \phi)$ results in the expression:

$$-m\omega_n^2 + k = 0 \quad (2.6)$$

This expression can be rearranged into the more useful standard form:

$$\omega_n = \sqrt{\frac{k}{m}} \quad (2.7)$$

Equation 2.7 represents a solution to the EOM presented in equation 2.1. This solution is not in the form of an ODE so, therefore, we can experimentally prove that this is the correct solution. For example, we could build a system with known mass and stiffness and measure the natural frequency of the system. Equation 2.7 equation leads to:

$$T = \frac{2\pi}{\omega_n} \quad (2.8)$$

where T is the period of oscillations and

$$f_n = \frac{\omega_n}{2\pi} \quad (2.9)$$

where f_n is the frequency of the oscillations.

NOTE

Radians are considered a dimensionless quantity and as such the units of $m\omega_n^2$ become $\frac{\text{kg}}{\text{s}^2} \cdot \frac{\text{m}}{\text{m}}$ where the unit value $\frac{\text{m}}{\text{m}}$ is added such that the stiffness of the spring can be expressed as $\frac{\text{kg}\cdot\text{m}}{\text{s}^2} \cdot \frac{1}{\text{m}} = \frac{\text{N}}{\text{m}}$. The International System of Units (SI) defines radians as a derived unit for measuring angles. Interestingly, the topic is still discussed by some^a.

2.1.2 Solve for Initial Phase (ϕ) of the System

The EOM is a second-order ODE so there needs to exist two initial conditions (constants) to solve it. For the systems under consideration, the displacement (x) and velocity (\dot{x} or v) at $t = 0$ are the initial conditions. For simplicity, these are written as

$$x(0) = x_0 \quad (2.10)$$

$$\dot{x}(0) = v(0) = v_0 \quad (2.11)$$

Setting the equation to its initial state $t = 0$, the equations for displacement and velocity can be simplified to:

$$x(0) = x_0 = A\sin(\omega_n 0 + \phi) = A\sin(\phi) \quad (2.12)$$

$$\dot{x}(0) = v_0 = A\omega_n \cos(\omega_n 0 + \phi) = A\omega_n \cos(\phi) \quad (2.13)$$

Thereafter, mathematical meanings for ϕ and A can be derived. To do this, ϕ can be solved for by rearranging equations 2.12 and 2.13 for A :

$$A = \frac{x_0}{\sin(\phi)} \quad (2.14)$$

and:

$$A = \frac{v_0}{\omega_n \cos(\phi)} \quad (2.15)$$

Setting these two equations equal to each other cancels out A and creates:

$$\frac{x_0 \omega_n}{\sin(\phi)} = \frac{v_0}{\cos(\phi)} \quad (2.16)$$

therefore:

$$\frac{x_0 \omega_n}{v_0} = \frac{\sin(\phi)}{\cos(\phi)} \quad (2.17)$$

finally:

$$\phi = \tan^{-1} \left(\frac{x_0 \omega_n}{v_0} \right) \quad (2.18)$$

^aQuincey, Paul. "Angles in the SI: treating the radian as an independent, unhidden unit does not require the redefinition of the term 'frequency' or the unit hertz." *Metrologia* 57.5 (2020):053001.

2.1.3 Solve for Amplitude (A) of the System

The amplitude of the vibrating system (A) is solved for in a similar manner to ϕ where the expressions for x and \dot{x} are solved for at $t = 0$ and rearranged as to isolate ϕ . This operation results in the equations:

$$\sin(\phi) = \frac{x_0}{A} \quad (2.19)$$

and:

$$\cos(\phi) = \frac{v_0}{\omega_n A} \quad (2.20)$$

From these equations a value for ϕ can be obtained knowing that $\sin^2(\phi) + \cos^2(\phi) = 1$. Therefore:

$$\left(\frac{x_0}{A}\right)^2 + \left(\frac{v_0}{\omega_n A}\right)^2 = 1 \quad (2.21)$$

multiplying each expression by 1 (also expressed as $\frac{\omega_n}{\omega_n}$), gives the equation:

$$\left(\frac{\omega_n}{\omega_n}\right)^2 \left(\frac{x_0}{A}\right)^2 + 1 \left(\frac{v_0}{\omega_n A}\right)^2 = 1 \times 1 \quad (2.22)$$

which becomes:

$$\left(\frac{\omega_n x_0}{\omega_n A}\right)^2 + \left(\frac{v_0}{\omega_n A}\right)^2 = 1 \quad (2.23)$$

Further simplification is obtained by multiplying each side by $(\omega_n A)^2$ to obtain:

$$\omega_n^2 x_0^2 + v_0^2 = A^2 \omega_n^2 \quad (2.24)$$

Solving for A , this expression rearranges to:

$$A = \frac{\sqrt{\omega_n^2 x_0^2 + v_0^2}}{\omega_n} = \sqrt{x_0^2 + \left(\frac{v_0}{\omega_n}\right)^2} \quad (2.25)$$

2.1.4 Response for Simple Harmonic Motion

The time-varying displacement of a 1-DOF vibrating system under free response is expressed by the equation $x(t) = A \sin(\omega_n t + \phi)$. Substituting in the expressions for A and ϕ results in:

$$x(t) = \frac{\sqrt{\omega_n^2 x_0^2 + v_0^2}}{\omega_n} \sin\left(\omega_n t + \left(\tan^{-1}\left(\frac{x_0 \omega_n}{v_0}\right)\right)\right) \quad (2.26)$$

This equation provides a mathematical solution that relates displacement of the mass to the initial conditions x_0 and v_0 . The solution is considered a free-response because no input is applied after $t=0$. The relationship between the initial conditions (x_0 and v_0) and the amplitude and phase of the response can be expressed using the Pythagorean theorem, $a^2 + b^2 = c^2$, as annotated in figure 2.5.

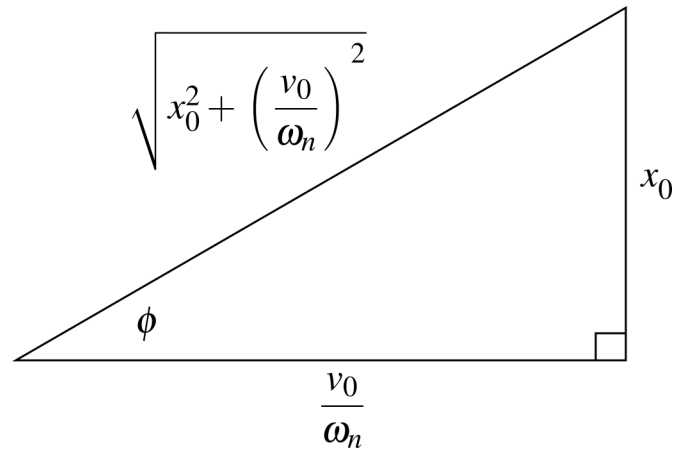

Figure 2.5: Trigonometric relationship between the initial conditions (x_0 and v_0), amplitude A , and phase ϕ for free vibration of a 1-DOF system.

2.1.5 Special Considerations for No Initial Velocity ($v_0 = 0$)

Upon close inspection of the temporal solution in equation 2.26, it becomes evident that any system without initial velocity (i.e. $v_0 = 0$) results in an undefined number for $(x_0\omega_n)/v_0$. A solution to this challenge lies in the fact that the limit of $\tan^{-1}(x)$ approaches $-\pi/2$ at $-\infty$ and $\pi/2$ at ∞ , as depicted in figure 2.6. Therefore, the solution at $-\infty$ and ∞ is undefined, resulting in the expression:

$$\left(\frac{x_0\omega_n}{v_0}\right) = \pm\frac{\pi}{2}, \text{ when } v_0 = 0 \quad (2.27)$$

This step is applied in IEEE floating-point arithmetic (IEEE 754) and results in $\pm\pi/2$ depending on the rounding format used. From the practitioner's side, it becomes important to recognize the situation $v_0 = 0$ and correct this value as needed.

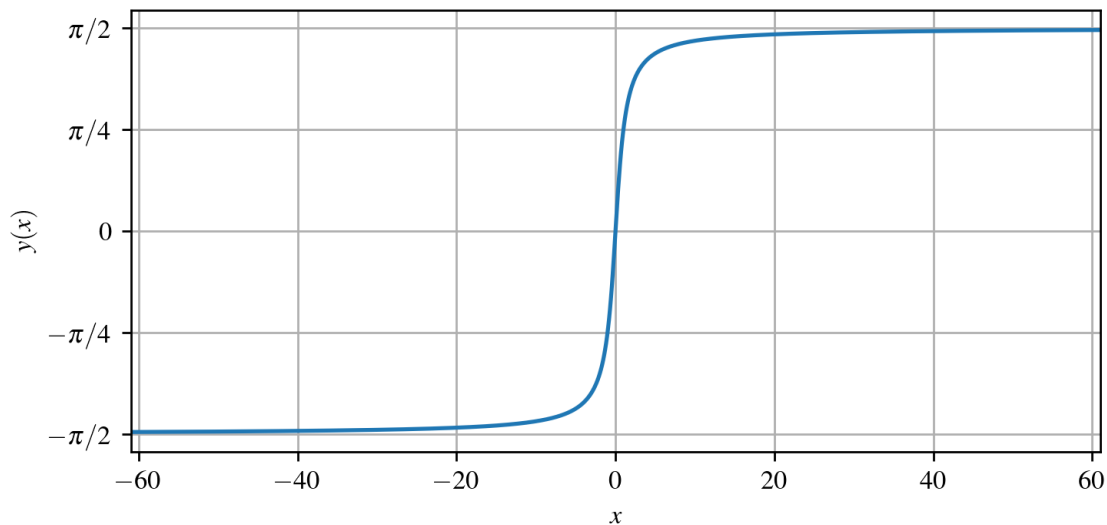

Figure 2.6: Response of \tan^{-1} (or arctan) for $x = -60$ to 60 showing that the \tan^{-1} is undefined as $-\pi/2$ or $\pi/2$ as x approaches $-\infty$ or ∞ , respectively.

Example 2.1 Vehicle Suspension Modeling

A vehicle wheel, tire, and suspension can be modeled as an SDOF spring and mass as depicted below: The mass of the wheel and tire is measured to be 300 kg and its frequency of oscillation is observed to be 10 rad/sec. What is the stiffness of the wheel assembly?

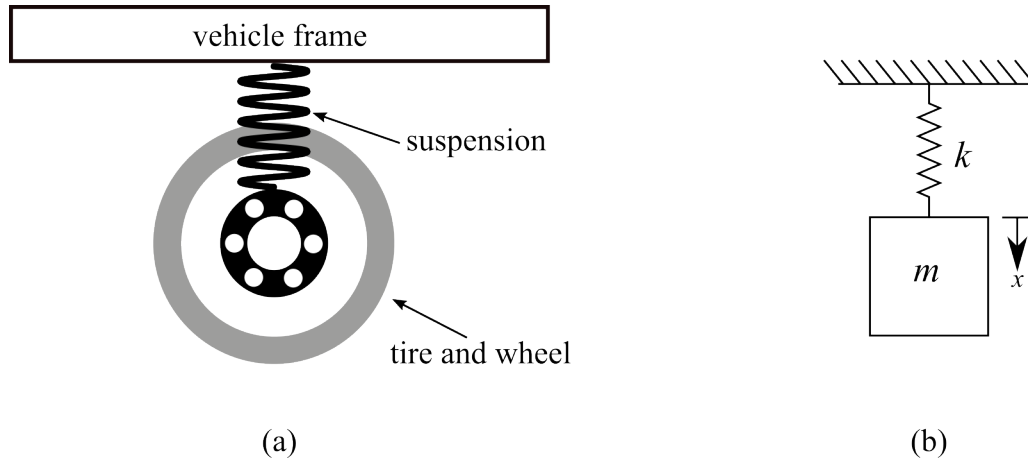

Figure 2.7: Modeling of a vehicle wheel, tire, and suspension showing: (a) Graphical representation; and (b) a spring-mass model.

Solution:

Considering:

$$\omega_n = \sqrt{\frac{k}{m}} \quad (2.28)$$

therefore, $k = m\omega_n^2 = (300 \text{ kg})(10 \text{ rad/s})^2 = 30 \text{ KN/m}$.

Vibration Case Study 2.1 Suspension on Early Tractors

The Hart-Parr 20-40 “Steel King” was an early gas internal combustion engine built in Charles City Iowa^a from 1911-1914. Hart-Parr was the inventor of the world’s first commercially successful tractor. These large frame tractors were used for sod busting on the prairie and road construction. They were dual cylinders and ran on either gasoline or kerosene and water. Each cylinder has an 8-inch bore and a 12-inch stroke. The Hart-Parr 20-40 used an innovative in-hub suspension setup on the front wheel intended to help smooth out the ride in the tractor when used for road construction. However, without a damper integrated into the suspension the suspension proved to be unhelpful, and future refinements of the tractor dropped this feature.

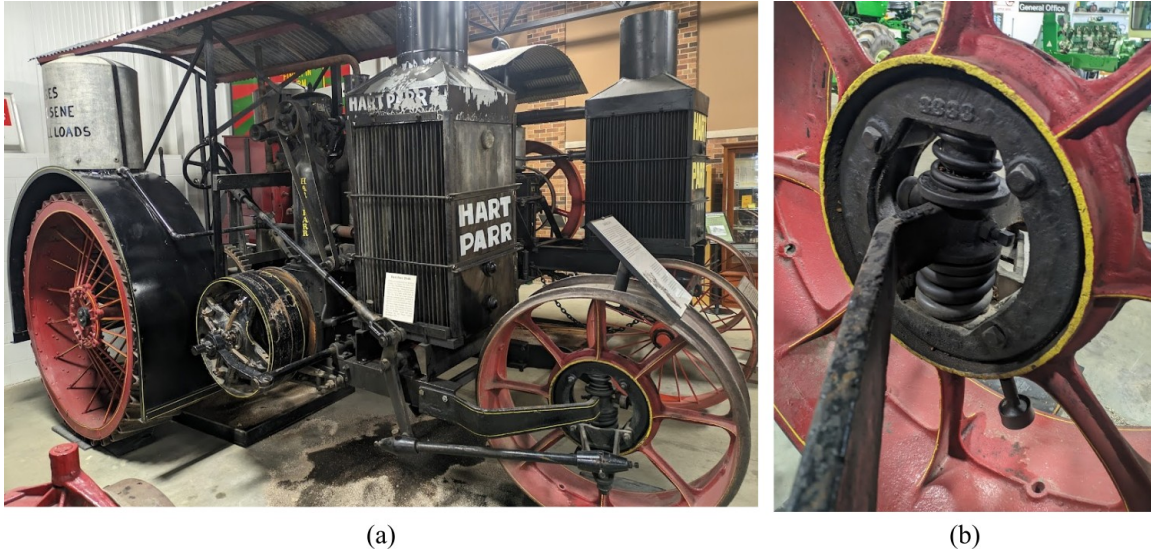

Figure 2.8: Hart-Parr 20-40, showing: (a) the full tractor, and; (b) close up of suspension in the front hub.

^aAustin Downey's hometown.

Example 2.2 Calculating Natural Frequency

Consider the following 1-DOF system, where $k = 857.8 \text{ N/m}$ and $m = 49.2 \times 10^{-3} \text{ kg}$, and calculate the natural frequency in rad/s and Hz. Also, find the period of oscillations and the maximum displacement if the spring is initially displaced 10 mm with no initial velocity.

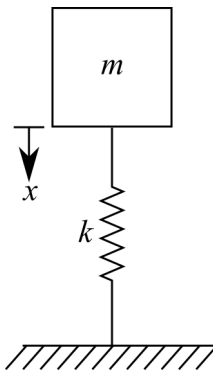

Figure 2.9: 1-DOF spring-mass system.

Solution:

Setting up as solving for the natural frequency results in:

$$\omega_n = \sqrt{\frac{k}{m}} = \sqrt{\frac{857.8}{49.2 \times 10^{-3}}} = 132 \text{ rad/sec} \quad (2.29)$$

In Hz, this is:

$$f_n = \frac{\omega_n}{2\pi} = 21 \text{ Hz} \quad (2.30)$$

The period is:

$$T = \frac{2\pi}{\omega_n} = 0.0476 \text{ s} \quad (2.31)$$

The maximum displacement will happen when $\sin(\omega_n t + \phi) = 0$, therefore, the value of A is the maximum displacement. For an undamped system, $A = \frac{\sqrt{\omega_n^2 x_0^2 + v_0^2}}{\omega_n}$,

$$A = \frac{\sqrt{\omega_n^2 x_0^2 + v_0^2}}{\omega_n} = \frac{\sqrt{132^2 \cdot 0.01^2 + 0^2}}{132} = 0.01 \text{ m} \quad (2.32)$$

2.2 General Solution for Vibrating Systems

The EOM for a vibrating system has many solutions and can be expressed in various forms including a general solution. These forms offer different mathematical approaches to solve the same 1-DOF spring-mass system and relate to each other through Euler's equations.

Review 2.1 Complex Plane

Vibration analysis uses complex numbers to solve the EOM's differential equation. In this text the imaginary number is termed j (sometimes referred to as i): such that:

$$j = \sqrt{-1} \quad (2.33)$$

and:

$$j^2 = -1 \quad (2.34)$$

A general complex number, x , can be expressed as:

$$x = a + bj \quad (2.35)$$

here, a is referred to as the real number and b is the imaginary part of the number x . Such complex numbers can be represented in the complex plane, also called an Argand plot. The absolute value or modules is defined as $|x|$ presented on the complex plot.

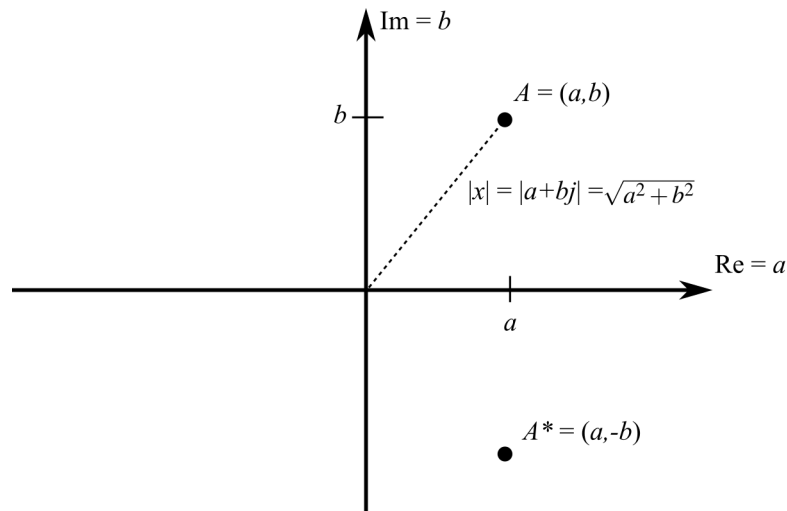

Figure 2.10: A conjugate pair of numbers (A and A^*) represented on the complex plane.

A and A^* prime are complex conjugate pairs. In mathematics, the complex conjugate of a complex number is the number with an equal real part and an imaginary part equal in magnitude but opposite in sign. In other words, a conjugate pair is $a + bj$ and $a - bj$.

Definition - con·ju·gate (adjective): Coupled, connected, or related.

Review 2.2 Euler's Formula

Euler's (pronounced oy-ler) formula, is a mathematical formula in complex analysis that establishes the fundamental relationship between the trigonometric functions and the complex exponential function. Euler's formula states that for any real number x ,

$$e^{j\psi} = \cos(\psi) + j\sin(\psi) \quad (2.36)$$

where $j = \sqrt{-1}$. This equation can also be expressed as:

$$e^{-j\psi} = \cos(\psi) - j\sin(\psi) \quad (2.37)$$

This can be expressed in terms of polar coordinates as:

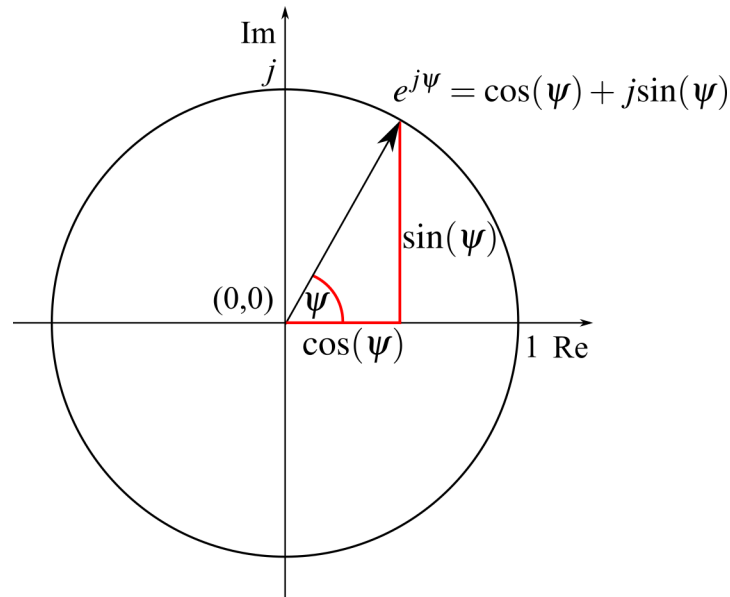

Figure 2.11: Euler's formula illustrated on the unit circle in the complex plane.



Figure 2.12: A Soviet Union stamp from 1957 with a Portrait of Leonhard Euler who worked in various branches of the Imperial Russian Academy of Sciences and Imperial court during his lifetime^a.

Euler's formula is named after the Swiss engineer and mathematician Leonhard Euler (1707-1783), who among other things popularized the use of the Greek letter π to denote the ratio of a circle's circumference to its diameter, was the first to use the expression $f(x)$ to denote a function, and correctly defining the base of the natural logarithm e ; which is now known as Euler's number. While Euler developed "Euler's formula" in 1748, it was

not used to describe points in a complex for another 50 years when the Danish-Norwegian mathematician and cartographer Caspar Wessel presented to the Danish Academy in 1797^b.

^aPost of the USSR, Public domain, via Wikimedia Commons

^bWhittaker, Edmund Taylor, and George Neville Watson. A course of modern analysis: an introduction to the general theory of infinite processes and of analytic functions; with an account of the principal transcendental functions. University Press, 1927.

2.2.1 Formulating the General Solution for a 1-DOF Spring-Mass System

We can also solve the following EOM as an elementary differential equation:

$$m\ddot{x} + kx = 0 \quad (2.38)$$

in a more analytical manner using the theory of elementary differential equations. To do this the form:

$$x(t) = ae^{\lambda t} \quad (2.39)$$

is assumed, where a and t are nonzero constants that need to be determined. Using successive differentiation, the assumed solution becomes:

$$\dot{x}(t) = \lambda ae^{\lambda t} \quad (2.40)$$

and

$$\ddot{x}(t) = \lambda^2 ae^{\lambda t} \quad (2.41)$$

therefore, $m\ddot{x}(t) + kx(t) = 0$ becomes:

$$m\lambda^2 ae^{\lambda t} + kae^{\lambda t} = 0 \quad (2.42)$$

Next, the above expressions is divide by $ae^{\lambda t}$ to obtain the characteristic equation:

$$m\lambda^2 + k = 0 \quad (2.43)$$

This can be done because $ae^{\lambda t}$ is never zero, therefore, the expression is never divided by zero. The quadratic formula gives us:

$$\lambda = \pm \sqrt{-\frac{k}{m}} = \pm \sqrt{\frac{k}{m}}j = \pm \omega_n j \quad (2.44)$$

remember that $\omega_n = \sqrt{\frac{k}{m}}$. Notice that the \pm tells us there are two solutions to this problem. So, putting λ back into the assumed solution results in two solutions (one positive, one negative):

$$x(t) = a_1 e^{+\omega_n j t} \quad (2.45)$$

and

$$x(t) = a_2 e^{-\omega_n j t} \quad (2.46)$$

As these solutions only consider, and are only valid for, linear systems; the sum of the solutions is also a solution. This simplification results in:

$$x(t) = a_1 e^{+\omega_n j t} + a_2 e^{-\omega_n j t} \quad (2.47)$$

where a_1 and a_2 are constants of integration that scale the unit Euler's vector. The positive and negative values in the exponent indicate that the terms are a conjugate pair.

Review 2.3 Superposition of Linear Systems

In linear algebra, the principle of superposition is a fundamental characteristic of linear systems. It states that if x_1 and x_2 are solutions to a linear system $Ax = b$, where A is a matrix and b is a vector, then any linear combination of these solutions is also a solution to the system.

Mathematically, if $Ax_1 = b$ and $Ax_2 = b$, then for any scalars α and β , the vector $\alpha x_1 + \beta x_2$ is also a solution. This can be demonstrated as:

$$A(\alpha x_1 + \beta x_2) = \alpha Ax_1 + \beta Ax_2 = \alpha b + \beta b = (\alpha + \beta)b \quad (2.48)$$

This principle allows for the construction of the general solution to a linear system.

Example 2.3 Equivalences of Mathematical Vibration Models

Show that $x(t) = a_1 e^{+\omega_n j t} + a_2 e^{-\omega_n j t}$ is equal to $A \sin(\omega_n t + \phi)$.

Solution:

This equation was derived using Euler's formula and it can be shown that this equation is equivalent to the $A \sin(\omega_n t + \phi)$. To recover the previously assumed solution, the knowledge that a_1 and a_2 are complex conjugate pairs and as such the magnitude can be expressed as $a_1 = a_2$ is leveraged. Using Euler's polar notation, a_1 and a_2 can be expressed as

$$a_1 = a_2 = a e^{j\psi} \quad (2.49)$$

where a and ψ are real numbers, the equation becomes:

$$x(t) = a e^{j(\omega_n t + \psi)} + a e^{-j(\omega_n t + \psi)} \quad (2.50)$$

this becomes:

$$x(t) = a(e^{j(\omega_n t + \psi)} + e^{-j(\omega_n t + \psi)}) \quad (2.51)$$

Remembering Euler's equations from before, this becomes:

$$x(t) = a(\cos(\omega_n t + \psi) + j \sin(\omega_n t + \psi) + \cos(\omega_n t + \psi) - j \sin(\omega_n t + \psi)) \quad (2.52)$$

combining the "cos" terms and canceling out the "sin" terms this becomes:

$$x(t) = 2a \cdot \cos(\omega_n t + \psi) \quad (2.53)$$

This is equivalent to $x(t) = A \sin(\omega_n t + \phi)$ considering that $A = 2a$ and knowing $\sin(\phi) = \cos(\phi + \psi)$. To expand, this is because the sin and cos are only differentiated by a phase shift.

Next, a general solution for the EOM is obtained. Using the previous solution:

$$x(t) = a_1 e^{+\omega_n j t} + a_2 e^{-\omega_n j t} \quad (2.54)$$

we can expand this into the form:

$$x(t) = a_1 (\cos(\omega_n t) + j \sin(\omega_n t)) + a_2 (\cos(\omega_n t) - j \sin(\omega_n t)) \quad (2.55)$$

using trigonometric functions. This equates to:

$$x(t) = (a_1 + a_2) \cdot \cos(\omega_n t) + (a_1 - a_2)j \cdot \sin(\omega_n t) \quad (2.56)$$

As $x(t)$ is always real, A_1 and A_2 can be defined as:

$$A_1 = (a_1 + a_2) \quad (2.57)$$

and

$$A_2 = (a_1 - a_2)j \quad (2.58)$$

Lastly, the general solution is written as:

$$x(t) = A_1 \cos(\omega_n t) + A_2 \sin(\omega_n t) \quad (2.59)$$

This is the general solution for the EOM ($m\ddot{x} + kx = 0$) of the considered oscillating system where A_1 and A_2 are defined as:

$$A = \sqrt{A_1^2 + A_2^2} \quad (2.60)$$

and

$$\phi = \tan^{-1}\left(\frac{A_1}{A_2}\right) \quad (2.61)$$

These are obtained from a trigonometric relationship, similar to that used before:

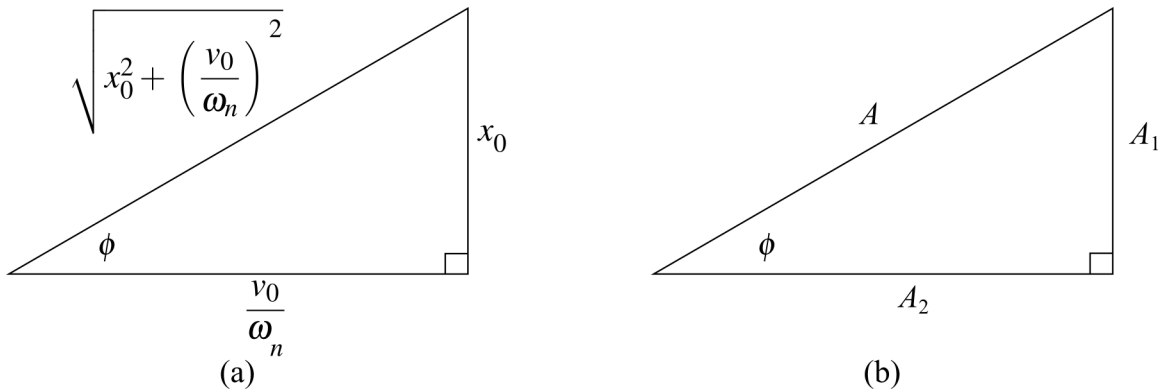

Figure 2.13: Trigonometric relationship between the initial conditions, amplitude, and phase, for free vibration of a 1-DOF system expressed with: (a) variables for initial conditions; and (b) generic variables A_1 and A_2 .

again, A and ϕ are:

$$A = \frac{\sqrt{\omega_n^2 x_0^2 + v_0^2}}{\omega_n} = \sqrt{x_0^2 + \left(\frac{v_0}{\omega_n}\right)^2} \quad (2.62)$$

$$\phi = \tan^{-1}\left(\frac{x_0 \omega_n}{v_0}\right) \quad (2.63)$$

Example 2.4 Solving for Constants in the General Solution

Using the general solution:

$$x(t) = A_1 \cos(\omega_n t) + A_2 \sin(\omega_n t) \quad (2.64)$$

Calculate the values of A_1 and A_2 in terms of their initial conditions x_0 and v_0 .

Solution:

Knowing the following for x and \dot{x} :

$$x(t) = A_1 \cos(\omega_n t) + A_2 \sin(\omega_n t) \quad (2.65)$$

$$\dot{x}(t) = -A_1 \omega_n \sin(\omega_n t) + A_2 \omega_n \cos(\omega_n t) \quad (2.66)$$

Now apply the initial conditions, $x(0) = 0$ and $v(0) = 0$, this yields:

$$x(0) = x_0 = A_1 \quad (2.67)$$

$$\dot{x}(0) = v_0 = A_2 \omega_n \quad (2.68)$$

Solving for A_1 and A_2 shows us:

$$A_1 = x_0, \text{ and } A_2 = \frac{v_0}{\omega_n} \quad (2.69)$$

thus:

$$x(t) = x_0 \cos(\omega_n t) + \frac{v_0}{\omega_n} \sin(\omega_n t) \quad (2.70)$$

2.2.2 Solution of 1-DOF System in Three Forms

Form one, for $m\ddot{x} + kx = 0$ subject to nonzero initial conditions can be written as:

$$x(t) = a_1 e^{+\omega_n j t} + a_2 e^{-\omega_n j t} \quad (2.71)$$

where a_1 and a_2 are complex terms. Form two is:

$$x(t) = A \sin(\omega_n t + \phi) \quad (2.72)$$

while form three is:

$$x(t) = A_1 \cos(\omega_n t) + A_2 \sin(\omega_n t) \quad (2.73)$$

where A , ϕ , A_1 , and A_2 , are all real-valued constants. Each set of constants can be related to each other by:

$$A = \sqrt{A_1^2 + A_2^2} \quad \phi = \tan^{-1} \left(\frac{A_1}{A_2} \right) \quad (2.74)$$

$$A_1 = (a_1 + a_2) \quad A_2 = (a_1 - a_2)j \quad (2.75)$$

$$a_1 = \frac{A_1 - A_2 j}{2} \quad a_2 = \frac{A_1 + A_2 j}{2} \quad (2.76)$$

Which follow from trigonometric identities and Euler's formula.

2.3 Damping

The response of a spring-mass system predicts that a system will oscillate indefinitely. However, we know that this is not true from observing real-world solutions. So based on real-world observations and mathematical conveniences, we need to add a term that will remove “energy” from the system with time. To do this the idea of the ideal dashpot is introduced. A linear dashpot is diagrammed in figure 2.14 and is a mechanical device that resists motion via viscous friction and therefore converts the mechanical energy of the system into thermal energy that is dissipated.

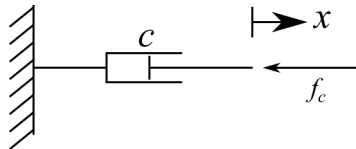

Figure 2.14: Schematic of a linear dashpot showing the damping force (f_c) acting in the opposite direction of the displacement (x).

Just as a spring forms a physical model of the cause vibration, through its storage and release of energy, a dashpot (sometimes called a damper) forms a physical model for dissipating energy. Dashpots create a resisting or damping force that acts opposite to the direction of travel (as annotated in figure 2.14) and is proportional to the velocity. Therefore, the damping forces f_c can be computed as:

$$f_c = c\dot{x} \quad (2.77)$$

the constant c , called the damping coefficient, has the units of kg/s. Dashpots are a mathematical representation of viscous dampers installed in automobiles, aircraft, structures, and other mechanical devices. However, all systems have inherent damping not just systems with physical dampers. The spring-mass system can be used as a representation of real-world systems with inherent damping as demonstrated by the rubber engine mount depicted in figure 2.15.

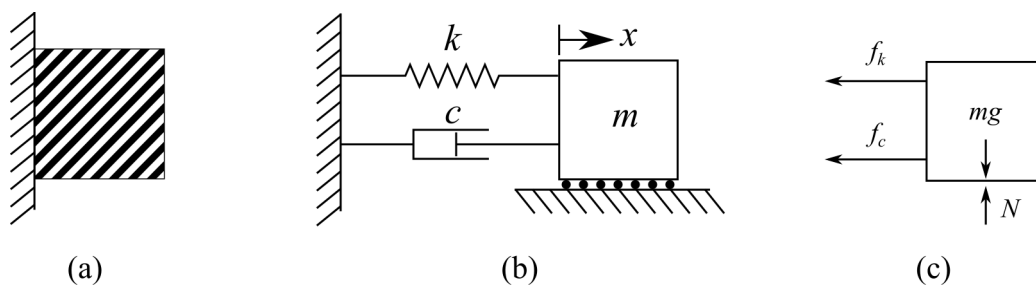

Figure 2.15: Modeling of a rubber engine mount as an spring-dashpot-mass model showing (a) the rubber engine mount; (b) idealized model of the rubber month; and (c) the FBD of the idealized model

2.3.1 Damping Cases

Depending on the amount of damping present in a system, the temporal response of the system will represent itself in various ways, as represented in figure 2.16. To reiterate, an undamped case will oscillate around the equilibrium and does not decay. If a limited amount of damping is present in a system it will oscillate around the equilibrium and slowly decay with time to the equilibrium position, this is termed underdamped. If an excessive amount of damping is present, the system will not oscillate but decay directly to the equilibrium position, this is termed the overdamped case. Lastly, there exists a special case that results in the system converging as quickly as possible to the equilibrium position without oscillations; this case is termed the critically damped case. Furthermore, the amount of damping required to obtain a critically damped system is the damping value between the underdamped and overdamped cases for a specific system. To recap, the key types of damping are:

- **Undamped** - Oscillates about the equilibrium and does not decay.
- **Underdamped** - Oscillates about the equilibrium and slowly decays and is the most common case.
- **Overdamped** - Does not pass the equilibrium position and is a simple decay with no oscillation.
- **Critically damped** - Provides the quickest approach to zero amplitude for a damped oscillator, no oscillation.

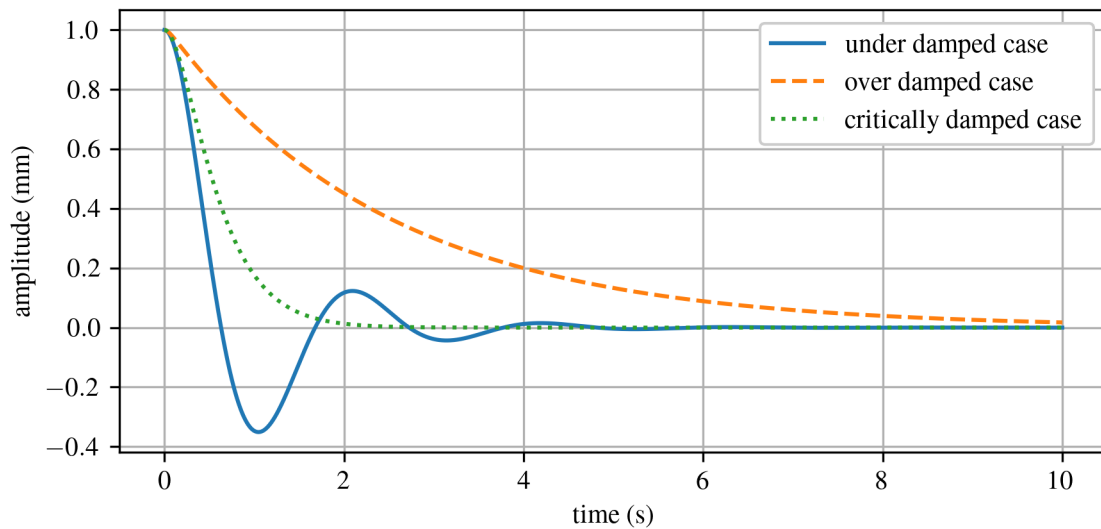

Figure 2.16: Temporal responses for the three types of damping: underdamped, overdamped, and critically damped.

Vibration Case Study 2.2 Supplemental Damping on Suspension Bridges

Dampers are used to extract energy from systems in an effort to reduce their vibrations. The Author Ravel Junior Bridge in Charleston South Carolina is a cable-stayed bridge over the Cooper River with a main span of 471 m (1,546 feet). The bridge uses two dampers connected to the cables in the middle of the bridge to dissipate excess energy in the cables that would otherwise cause unwanted vibrations from wind, traffic, and seismic activity. The inclusion of these dampers on the bridges is a proactive measure to enhance the bridge's performance, safety, and user experience by reducing the effects of vibrations.

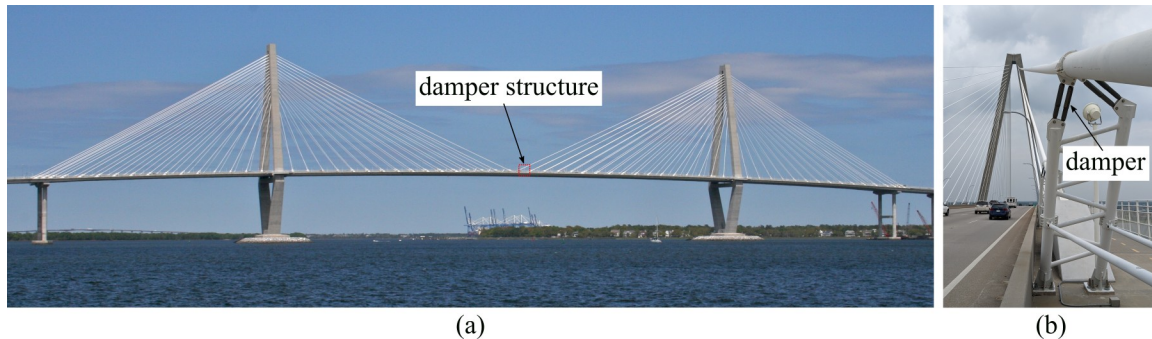

Figure 2.17: Dampers installed on the center cables of the Author Ravel Junior Bridge in Charleston South Carolina, showing: (a) the main span of the bridge taken from the water^a with the damper structure annotated; and (b) close up of the structure that holds the damper.

^aoriginal un-annotated image by bbatsell, CC BY-SA 2.5 <<https://creativecommons.org/licenses/by-sa/2.5/>>, via Wikimedia Commons

2.3.2 Modeling Systems with Damping

The spring-mass system of Chapter 1 can be expanded to a spring-dashpot-mass system that considers the damping component of the system. A mathematical model of the spring-dashpot-mass system can be developed for the case present in figure 2.18. Using the FBD for the system, it can conclude that the EOM for this system:

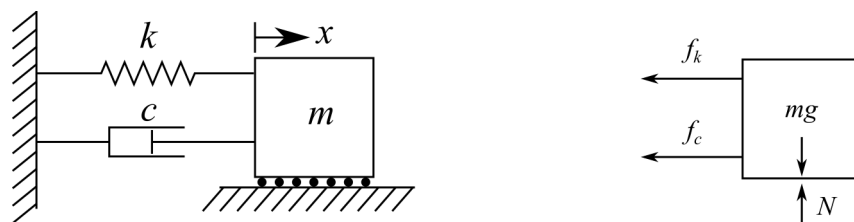

Figure 2.18: Spring-dashpot-mass model showing: (a) a schematic of the system; and (b) the FBD of the system.

is:

$$m\ddot{x}(t) = -f_c - f_k \quad (2.78)$$

Rearranging into standard form and concerting forces into parameters c and k results in:

$$m\ddot{x}(t) + c\dot{x}(t) + kx(t) = 0 \quad (2.79)$$

This system is subject to the same initial conditions as before, $x(0) = x_0$ and $\dot{x}(0) = v_0$. Again, choosing to model it this way for convinces, so let's solve it in a similar manner to the EOM without damping. Again, assume the solution:

$$x(t) = ae^{\lambda t} \quad (2.80)$$

here, a and t are nonzeros constants that need to be determined. Using successive differentiation, we get:

$$\dot{x}(t) = \lambda ae^{\lambda t} \quad (2.81)$$

and

$$\ddot{x}(t) = \lambda^2 ae^{\lambda t} \quad (2.82)$$

therefore, $m\ddot{x} + c\dot{x} + kx = 0$ becomes:

$$m\lambda^2 ae^{\lambda t} + c\lambda ae^{\lambda t} + kae^{\lambda t} = 0 \quad (2.83)$$

Now we divide by $ae^{\lambda t}$ to obtain the characteristic equation:

$$m\lambda^2 + c\lambda + k = 0 \quad (2.84)$$

We can do this because $ae^{\lambda t}$ is never zero, therefore, we never divide by zero. The quadratic formula gives us:

$$\lambda_{1,2} = \frac{-c \pm \sqrt{c^2 - 4km}}{2m} = \frac{-c}{2m} \pm \frac{1}{2m} \sqrt{c^2 - 4km} \quad (2.85)$$

Some key points from this equation:

- The \pm tells us there are two solutions to this problem
- if $c^2 - 4km < 0$, system is Underdamped, solutions are complex conjugate pairs
- if $c^2 - 4km = 0$, system is critically damped, solutions are equal negative real numbers
- if $c^2 - 4km > 0$, system is Overdamped, solutions are distinct negative real numbers

From this, we can see that $c^2 - 4km = 0$ is a special value, let us define a value for c that will give us this critical damping number. We will call it the critical damping coefficient (c_{cr}). So setting the equation as:

$$c_{cr}^2 - 4km = 0 \quad (2.86)$$

giving us:

$$c_{cr}^2 = 4km \quad (2.87)$$

next, we can derive the function:

$$c_{cr} = 2\sqrt{km} = 2\left(\frac{\sqrt{m}}{\sqrt{m}}\right)\sqrt{km} = 2m\omega_n \quad (2.88)$$

remember that $\omega_n = \sqrt{\frac{k}{m}}$ for an undamped system. Next, we generate a non-dimensional number (ζ), pronounced ‘zeta’ that will allow us to distinguish between different types of damping. ζ is called the critical damping ratio.

$$\zeta = \frac{c}{c_{cr}} = \frac{c}{2\sqrt{km}} = \frac{c}{2m\omega_n} \quad (2.89)$$

Now if we put the ζ back into the characteristic equation and resolve using the quadratic equation we get:

$$\lambda_{1,2} = -\zeta\omega_n \pm \omega_n\sqrt{\zeta^2 - 1} \quad (2.90)$$

From this equation, it becomes clear that ζ determines whether the roots are complex or real, this, in turn, determines the nature of the response of the structure. Listing the possible responses we get: For each damping case, we will have a different solution to the problem.

damping case	critical damping ratio	radicand	solutions
under damped	$0 < \zeta < 1$	$c^2 - 4km < 0$	complex conjugate pairs
critically damped	$\zeta = 1$	$c^2 - 4km = 0$	equal negative real numbers
over damped	$1 < \zeta$	$c^2 - 4km > 0$	distinct negative real numbers

2.3.3 Modeling Underdamped Motion

In the case that $0 < \zeta < 1$, a complex conjugate pair of roots are the solutions to the characteristic equation after pulling out a $\sqrt{-1}$:

$$\lambda_1 = -\zeta\omega_n + \omega_n\sqrt{1 - \zeta^2}j \quad (2.91)$$

and:

$$\lambda_2 = -\zeta\omega_n - \omega_n\sqrt{1 - \zeta^2}j \quad (2.92)$$

Where the j is pulled out because:

$$\sqrt{1 - \zeta^2}j = \sqrt{(1 - \zeta^2)(-1)} = \sqrt{\zeta^2 - 1} \quad (2.93)$$

Next, let us “arbitrarily” define:

$$\omega_d = \omega_n\sqrt{1 - \zeta^2} \quad (2.94)$$

where ω_d is the **damped natural frequency**. Therefore, the equations become:

$$\lambda_1 = -\zeta\omega_n + \omega_d j \quad (2.95)$$

and:

$$\lambda_2 = -\zeta\omega_n - \omega_d j \quad (2.96)$$

Again, we have two solutions to a linear problem, so we can combine these into one solution and insert λ into the assumed solution $ae^{\lambda t}$ to obtain:

$$x(t) = a_1 e^{-\zeta \omega_n t + \omega_d t j} + a_2 e^{-\zeta \omega_n t - \omega_d t j} \quad (2.97)$$

where a_1 and a_2 are complex valued constants. This can now be simplified into:

$$x(t) = e^{-\zeta \omega_n t} (a_1 e^{\omega_d t j} + a_2 e^{-\omega_d t j}) \quad (2.98)$$

Using Euler's equations, (same as before) and choosing:

$$A_1 = (a_1 - a_2)j \quad (2.99)$$

and

$$A_2 = (a_1 + a_2) \quad (2.100)$$

Note that the A_1 and A_2 defined here are the reverse of those defined in Eq. 2.74. This is done to allow the general form to be in the same format as before, however, assuming the same A_1 and A_2 would not change the final solution expressed below. The general form of this solution is then:

$$x(t) = e^{-\zeta \omega_n t} (A_1 \sin(\omega_d t) + A_2 \cos(\omega_d t)) \quad (2.101)$$

Recall that for undamped 1-DOF systems we showed

$$x(t) = A \sin(\omega_n t + \phi) = A_1 \sin(\omega_n t) + A_2 \cos(\omega_n t) \quad (2.102)$$

As $e^{-\zeta \omega_n t}$ accounts for the damping, our current solution becomes:

$$x(t) = A e^{-\zeta \omega_n t} \sin(\omega_d t + \phi) \quad (2.103)$$

Now that we have x and \dot{x} , we can solve for the boundary conditions x_0 and v_0 by setting $t = 0$, we get:

$$x(0) = x_0 = A \sin(\phi) \quad (2.104)$$

and taking the derivative of $x(t)$ using the product rule $(fg)' = f'g + fg'$, we get:

$$\dot{x}(t) = -\zeta \omega_n A e^{-\zeta \omega_n t} \sin(\omega_d t + \phi) + A e^{-\zeta \omega_n t} \omega_d \cos(\omega_d t + \phi) \quad (2.105)$$

$$\dot{x}(0) = v_0 = -\zeta \omega_n A \sin(\phi) + A \omega_d \cos(\phi) \quad (2.106)$$

a simplification can be made to the prior equation by letting $A = x_0 / \sin(\phi)$. This gives us the equation:

$$\dot{x}(0) = v_0 = -\zeta \omega_n \left(\frac{x_0}{\sin(\phi)} \right) \sin(\phi) + \left(\frac{x_0}{\sin(\phi)} \right) \omega_d \cos(\phi) \quad (2.107)$$

that can be simplified to:

$$\dot{x}(0) = v_0 = -\zeta \omega_n x_0 + x_0 \omega_d \cot(\phi) \quad (2.108)$$

The above equation related v_0 to ϕ using terms that are known for a given system (ζ , ω_n , x_0 , and ω_d). Therefore, this expression can be used to solve for ϕ :

$$\cot(\phi) = \frac{v_0 + \zeta \omega_n x_0}{x_0 \omega_d} \quad (2.109)$$

and as $\tan(\phi) = 1/\cot(\phi)$:

$$\phi = \tan^{-1} \left(\frac{x_0 \omega_d}{v_0 + \zeta \omega_n x_0} \right) \quad (2.110)$$

Thereafter, we can solve for A considering the fact that we sent $A = x_0/\sin(\phi)$. Using the trigonometric relationship between expressed in equation 2.109 and visualized in figure 2.19:

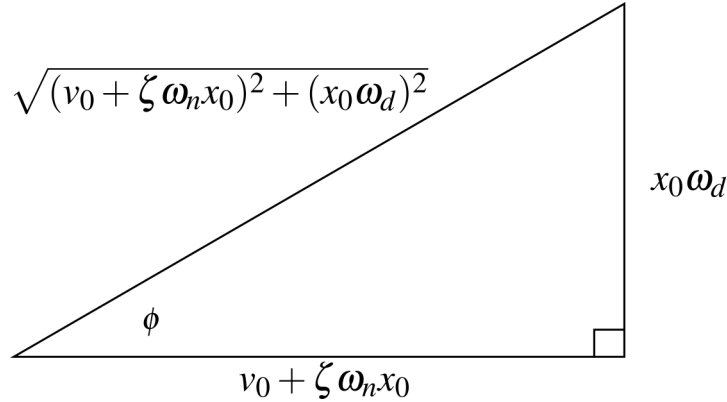

Figure 2.19: Trigonometric relationship between the initial conditions (x_0 and v_0), amplitude A , and phase ϕ for underdamped motion of a 1-DOF system.

we show that $\sin(\phi)$ can be expressed as:

$$\sin(\phi) = \frac{x_0 \omega_d}{\sqrt{(v_0 + \zeta \omega_n x_0)^2 + (x_0 \omega_d)^2}} \quad (2.111)$$

and applying $A = x_0/\sin(\phi)$ we get:

$$A = \frac{\sqrt{(v_0 + \zeta \omega_n x_0)^2 + (x_0 \omega_d)^2}}{\omega_d} = \sqrt{x_0^2 + \left(\frac{v_0 + \zeta \omega_n x_0}{\omega_d} \right)^2} \quad (2.112)$$

Finally, collecting all of our important equations:

- Critical damping coefficient: $c_{cr} = 2\sqrt{km} = 2m\omega_n$
- Damping ratio: $\zeta = \frac{c}{c_{cr}} = \frac{c}{2\sqrt{km}} = \frac{c}{2m\omega_n}$
- Damped natural frequency: $\omega_d = \omega_n \sqrt{1 - \zeta^2}$
- Solution for underdamped system: $x(t) = Ae^{-\zeta \omega_n t} \sin(\omega_d t + \phi)$, where:

$$A = \frac{\sqrt{(v_0 + \zeta \omega_n x_0)^2 + (x_0 \omega_d)^2}}{\omega_d} \quad \phi = \tan^{-1} \left(\frac{x_0 \omega_d}{v_0 + \zeta \omega_n x_0} \right)$$

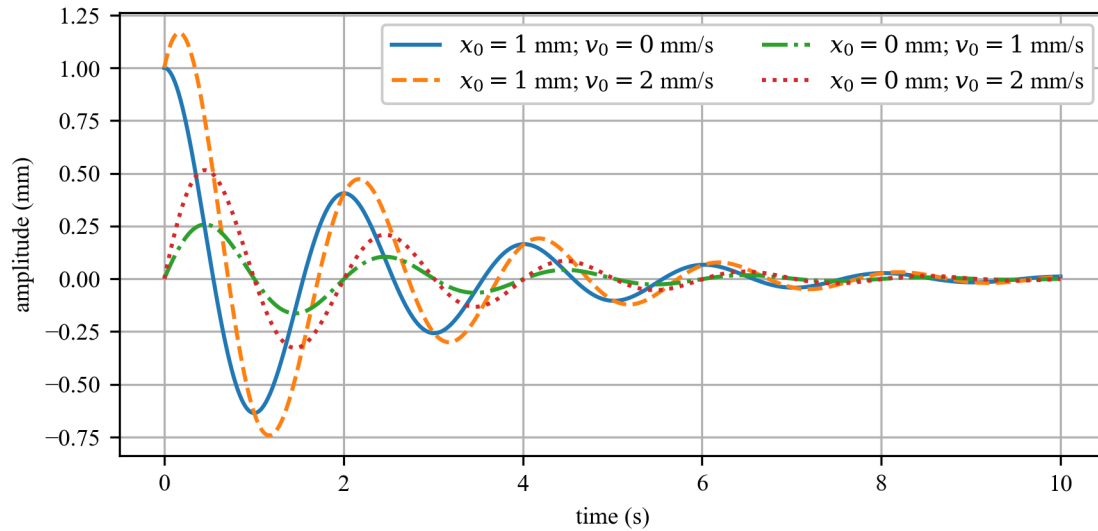

Figure 2.20: Four example responses for an underdamped 1-DOF system ($\zeta = 0.142$) with various initial conditions.

Example 2.5 Solving for Percent Damping

Consider the following 1-DOF system, where $k = 857.8$ N/m, $c = 7.8$ kg/s, and $m = 49.2 \times 10^{-3}$ kg, calculate the percentage of damping and the damped frequency in rad/s and Hz.

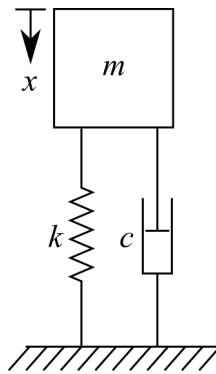

Figure 2.21: 1-DOF spring-dashpot-mass system.

Solution:

Calculate the undamped frequency:

$$\omega_h = \sqrt{\frac{k}{m}} = \sqrt{\frac{857.8}{49.2 \times 10^{-3}}} = 132 \text{ rad/s} \quad (2.113)$$

The systems critical damping value:

$$c_{cr} = 2\sqrt{km} = 2\sqrt{k \cdot m} = 2\sqrt{857.8 \cdot 49.2 \times 10^{-3}} = 12.993 \text{ kg/s} \quad (2.114)$$

And the critical damping ratio:

$$\zeta = \frac{c}{c_{cr}} = \frac{7.8}{12.993} = 0.600 \quad (2.115)$$

This can be expressed as 60% damped, this is an underdamped system, and the system will oscillate. Now we can calculate the damped frequency:

$$\omega_d = \omega_n \sqrt{1 - \zeta^2} = \omega_n \sqrt{1 - 0.600^2} = 105.6 \text{ rad/s} \quad (2.116)$$

Therefore, the system oscillates at 105.6 rad/sec or 16.81 Hz

Example 2.6 Solving for the Damping Case

For a damped one DOF system where m , c , and k are known to be $m = 1 \text{ kg}$, $c = 2 \text{ kg/s}$, and $k = 10 \text{ N/m}$. Calculate the value of ζ and ω_n . Is the system overdamped, underdamped, or critically damped?

Solution:

The natural frequency is calculated as

$$\omega_n = \sqrt{\frac{k}{m}} = \sqrt{\frac{10}{1}} = 3.16 \text{ rad/s} \quad (2.117)$$

The damping can be calculated as:

$$\zeta = \frac{c}{2\omega_n m} = \frac{2}{2\left(\sqrt{\frac{10}{1}}\right)(1)} = \frac{1}{\sqrt{10}} = 0.316 \quad (2.118)$$

So the damped natural frequency is equal to:

$$\omega_d = \omega_n \sqrt{1 - \zeta^2} = \sqrt{10} \sqrt{1 - \left(\frac{1}{\sqrt{10}}\right)^2} = 3 \text{ rad/s} \quad (2.119)$$

As $0 < \zeta < 1$ the system is underdamped.

Example 2.7 Off Orthogonal Stiffness

Figure 2.22 shows an industrial device consisting of a mass isolated from its fixtures by two rubber dampers and an offset spring with an angle α . Provide an estimate of the system's damped natural frequency in the vertical direction. Assume the rubber dampers add damping and only negligible stiffness to the system and that the spring is long enough such that the angles remain constant.

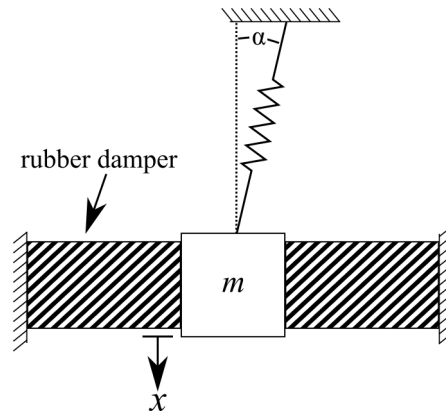

Figure 2.22: Industrial device (mass) connected to a fixed point with a rubber damper and spring at an angle.

Solution:

First and foremost, we need to develop a mass-spring-dashpot representation of the system. This is presented in figure 2.23 where the damping in the vertical direction provided by the rubber damper is modeled as a dashpot in the vertical direction. As we only want an estimate of the frequency, the assumption that the is small and as such α of the displaced state is equal α of the equilibrium state.

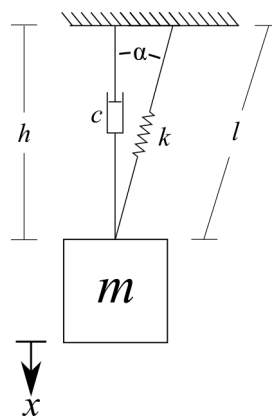
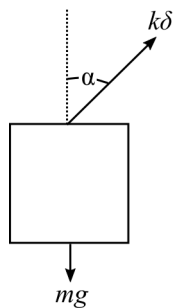

Figure 2.23: Mass-spring-dashpot representation of the industrial system represented in figure 2.22.

This leads to the FBD for the equilibrium and displaced states:

equilibrium position



displaced position “x”

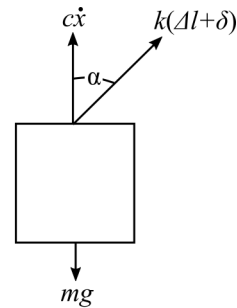

The equation for the equilibrium state is:

$$+\downarrow \sum F_x = mg - k\delta \cos(\alpha) = 0$$

and in the displaced state:

$$+\downarrow \sum F_x = mg - c\dot{x} - k\cos(\alpha)(\Delta l + \delta)$$

Applying Newton's second law and combining these equations yields:

$$m\ddot{x} + c\dot{x} + k\Delta l \cos(\alpha) = 0$$

Looking at the triangles formed by the dashpot and spring it can be shown that:

$$\cos(\alpha) = h/l = x/\Delta l$$

As we assumed the displacement is small and α remains unchanged. Therefore the prior equation becomes:

$$m\ddot{x} + c\dot{x} + k\Delta l \frac{x}{\Delta l} = 0$$

This simplifies to the “normal” EOM for a 1-DOF system:

$$m\ddot{x} + c\dot{x} + kx = 0$$

Therefore, once the values for the system are measured the system's damped natural frequency in the vertical direction can be estimated as

$$\omega_d = \omega_n \sqrt{1 - \zeta^2}$$

Vibration Case Study 2.3 Supplemental Damping in Automotive Damping

Epoxy-based damping is used in the automotive field to reduce vehicle noise and vibration harshness (NVH). This passive form of damping is essential for increasing comfort in modern light-wight vehicles.

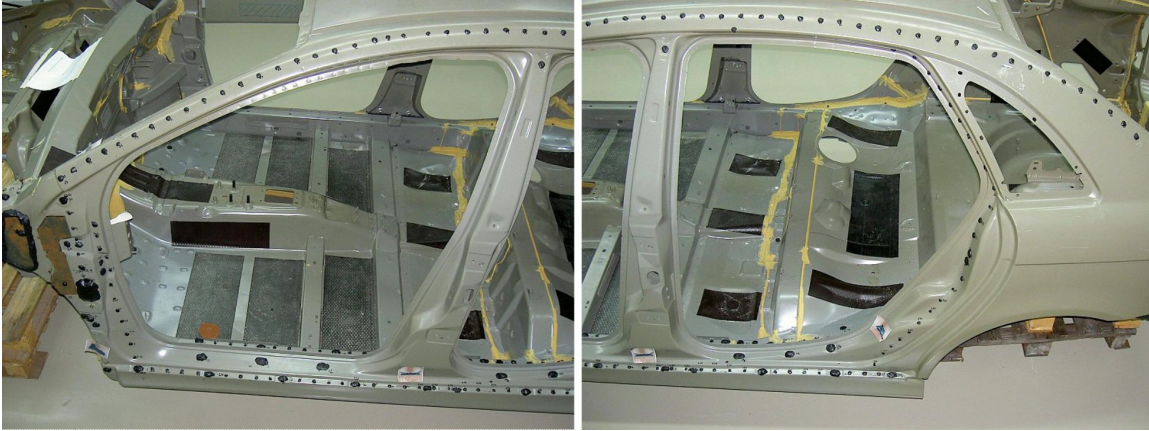

Figure 2.24: Experimental modal analysis of an automotive (Jaguar) body in white, typically done to reduce vehicle noise and vibration harshness^a.

^aCjp24, CC BY-SA 3.0 <<https://creativecommons.org/licenses/by-sa/3.0/>>, via Wikimedia Commons.

2.3.4 Modeling Overdamped Motion

In the case of overdamped systems, $1 < \zeta$, the solutions for λ are distinct real roots that are written as:

$$\lambda_1 = -\zeta \omega_n - \omega_n \sqrt{\zeta^2 - 1} \quad (2.120)$$

and:

$$\lambda_2 = -\zeta \omega_n + \omega_n \sqrt{\zeta^2 - 1} \quad (2.121)$$

The solution for the EOM using the assumed solution then becomes:

$$x(t) = e^{-\zeta \omega_n t} (a_1 e^{-\omega_n t \sqrt{\zeta^2 - 1}} + a_2 e^{+\omega_n t \sqrt{\zeta^2 - 1}}) \quad (2.122)$$

This equation represents a non-oscillating response of the system. Again, a_1 and a_2 are solved for using known boundary conditions x_0 and v_0 such that:

$$a_1 = \frac{-v_0 + \left(-\zeta + \sqrt{\zeta^2 - 1}\right) \omega_n x_0}{2\omega_n \sqrt{\zeta^2 - 1}} \quad (2.123)$$

$$a_2 = \frac{v_0 + \left(\zeta + \sqrt{\zeta^2 - 1}\right) \omega_n x_0}{2\omega_n \sqrt{\zeta^2 - 1}} \quad (2.124)$$

Typical responses for an overdamped system with various initial conditions are shown in figure 2.25.

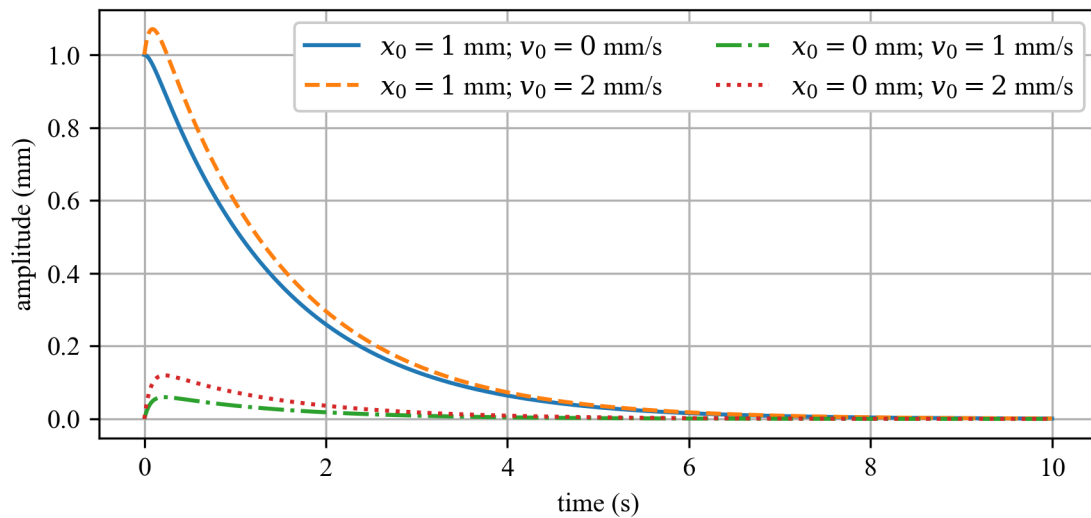

Figure 2.25: Four example responses for an overdamped 1-DOF system ($\zeta = 2.371$) with various initial conditions.

2.3.5 Modeling Critically Damped Motion

In the case of critically damped systems, $\zeta = 1$, the solutions for λ will be equal negative real numbers, therefore from before:

$$\lambda_{1,2} = -\zeta\omega_n \pm \omega_n\sqrt{\zeta^2 - 1} \quad (2.125)$$

We get:

$$\lambda_1 = \lambda_2 = -\omega_n \quad (2.126)$$

Because both solutions (a_1 and a_2) are the same, we multiply the second solution by t so the solution for a critically damped system is in the same form as before. The solution for the EOM using the assumed solution then becomes:

$$x(t) = a_1e^{-\omega_n t} + a_2te^{-\omega_n t} \quad (2.127)$$

This simplifies into:

$$x(t) = (a_1 + a_2t)e^{-\omega_n t} \quad (2.128)$$

This equation represents a non-oscillating response of the system. Again, a_1 and a_2 are solved for using known boundary conditions x_0 and v_0 such that:

$$a_1 = x_0 \quad (2.129)$$

$$a_2 = v_0 + \omega_n x_0 \quad (2.130)$$

2.3.6 Standard Form of the EOM

The EOM for a damped 1-DOF system is written in a “standard form” in which the effect of the damping ratio and natural frequencies are more obvious. To get to the standard form, the normal form of the EOM:

$$m\ddot{x} + c\dot{x} + kx = 0 \quad (2.131)$$

is divided by what the constant terms associated with the acceleration term. In this example, this is m . Dividing every term by m yields:

$$\ddot{x} + \frac{c}{m}\dot{x} + \frac{k}{m}x = 0 \quad (2.132)$$

Numerical manipulations can be undertaken to get the coefficients of the velocity and displacement terms into coefficients that more clearly express the characteristics of the vibrating system:

$$\ddot{x} + 2\zeta\omega_n\dot{x} + \omega_n^2x = 0 \quad (2.133)$$

Example 2.8 Vibration Modeling of Rocker Arm

An engine valve assembly is depicted in figure 2.26 where J is the inertia caused by the right-hand side of the rocker arm. Derive an analytical solution for the natural frequency of the rocker arm. Use the assumptions $\sin(\theta) = \theta$ and $\cos(\theta) = 1$.

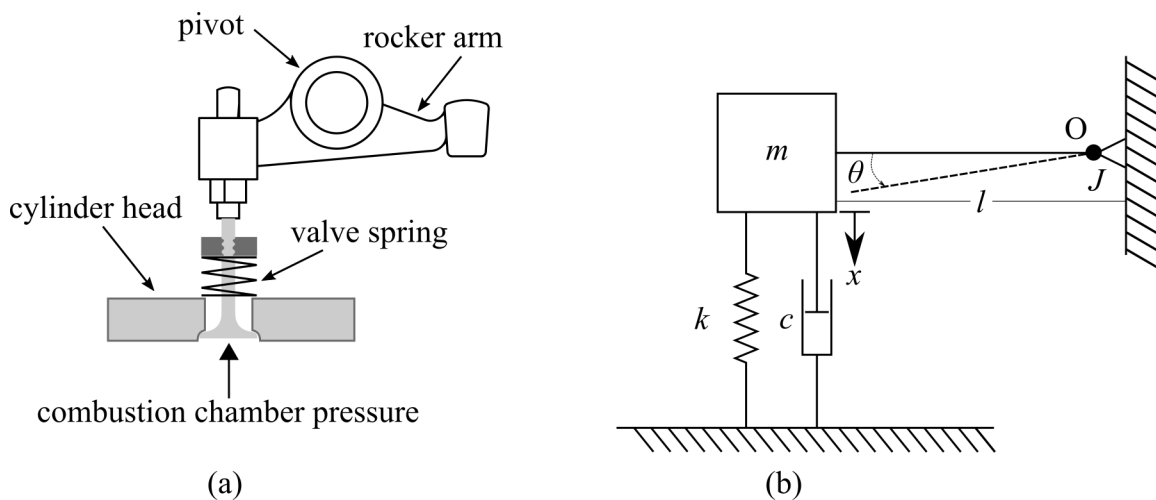

Figure 2.26: Rocker arm assembly of an internal combustion engine showing: (a) a diagram of the system and; (b) the FBD of the system.

Solution:

Taking the sum of the moments about O and considering the inertia caused by the right-hand side of the rocker arm, J , the FBDs can be written as:

equilibrium position

displaced position “ x ”

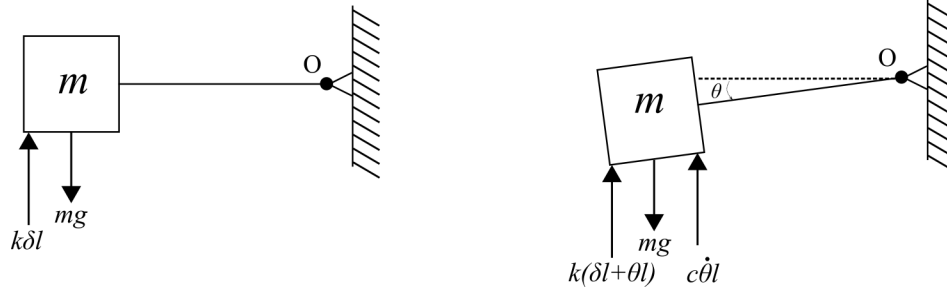

The equation for the equilibrium state is:

$$\zeta + \sum M_o = mgl - kl^2\delta = 0$$

and in the displaced state:

$$\zeta + \sum M_o = mgl - kl^2\delta - kl^2\theta - cl^2\dot{\theta} = 0$$

Applying Newton's second law and combining these equations yields:

$$(J + ml^2)\ddot{\theta} + cl^2\dot{\theta} + kl^2\theta = 0 \quad (2.134)$$

Therefore, the standard form of the EOM is:

$$\ddot{\theta} + \frac{cl^2}{J + ml^2}\dot{\theta} + \frac{kl^2}{J + ml^2}\theta = 0 \quad (2.135)$$

Results in the following analytical solution for the natural frequency:

$$\omega_n = \sqrt{\frac{kl^2}{J + ml^2}} \text{ rad/s} \quad (2.136)$$

Vibration Case Study 2.4 Vibration Induced Failure of Water Turbines

On August 17th, 2009 Turbine 2 of the hydroelectric power station of the Sayano-Shushenskaya Dam near Sayanogorsk in Russia failed catastrophically. The failure flooded the turbine hall and collapsed the ceiling. Killing 75 people, many of whom were in the turbine hall to celebrate the anniversary of the plant's general director. Turbines of the type used at Sayano-Shushenskaya are designed to have high efficiency but a very narrow working band. When they operate outside the designed working band, they vibrate due to the pulsation of water flow and water strokes. These vibrations degrade the turbine over time.

Turbine 2 had experienced excessive vibrations for a long time, ever since its installation in 1979. Through the early 1980s several issues were fixed, along with substantial repairs in 2000 and 2005. In July 2009 the turbine again exceeded the allowed vibration specification but stayed in operation. Over the years, the operating staff simply came to accept the higher level of vibration. The final government report stated that the accident was caused by turbine vibrations which led to fatigue damage in a turbine mount.



Figure 2.27: Sayano Shushenskaya's turbine hall before the accident where turbine 2 (the turbine that failed) is in the foreground of the image^a.



Figure 2.28: Sayano Shushenskaya's turbine hall after the accident^b.

^a4044415 Russian: Андрей Корзун English: Andrey Korzun, CC BY-SA 3.0 <<https://creativecommons.org/licenses/by-sa/3.0/>>, via Wikimedia Commons

^bThe original source of this photograph is believed to be Jaffaa, a user of forums.drom.ru, who uploaded it on August 17, 2009, a few hours after the accident. This image is a faithful digitization of a unique historic image, and the copyright for it is most likely held by the person who created the image or the agency employing the person. It is believed that the use of this image may qualify as fair use under the copyright law of the United States.

2.4 Logarithmic Decrement

For a vibrating system, the mass (m) and stiffness (k) can be measured using scales and static deflection tests. However, the damping coefficient (c) is a more difficult quantity to determine. From k and m we can compute the natural frequency (ω_n) and the critical damping coefficient (c_{cr}). Therefore, knowing that the critical damping ratio (ζ) is defined as:

$$\zeta = \frac{c}{c_{cr}} = \frac{c}{2\sqrt{km}} = \frac{c}{2m\omega_n} \quad (2.137)$$

if we calculate ζ , we can obtain c for the system of interest. This is made possible because c_{cr} can be calculated from k and m .

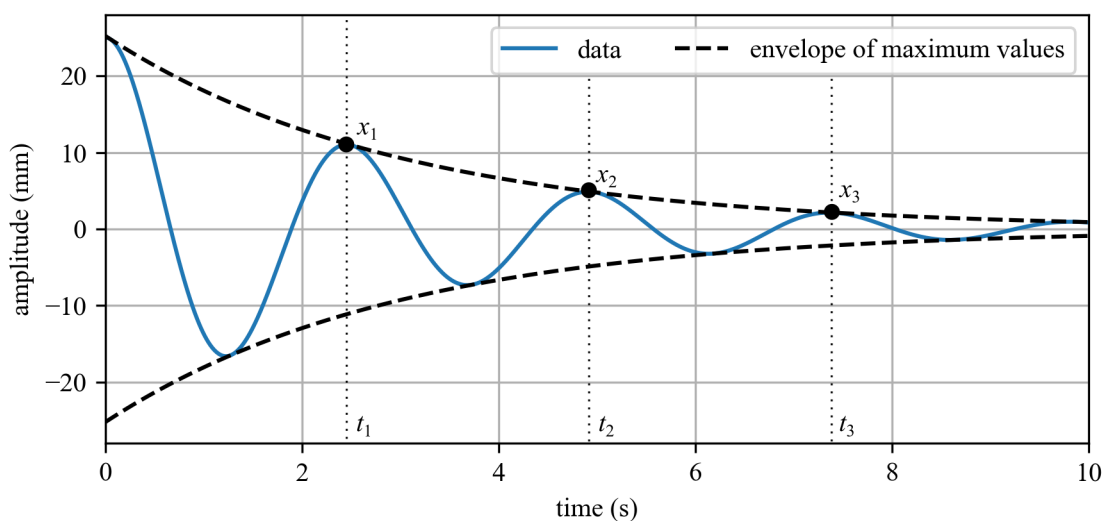

Figure 2.29: Measuring the peak displacement points in an experimental system with decay caused by damping.

Observing the temporal response for the underdamped system, we mark three points of maximum amplitude, x_1 , x_2 , and x_3 that happen at t_1 , t_2 , and t_3 , respectively. Considering displacement values for the first two points x_1 and x_2 , separated by a complete period (T). Knowing that one cycle is 2π , the time period for this complete cycle is given by:

$$t_2 - t_1 = \frac{2\pi}{\omega_d} = \frac{2\pi}{\omega_n \sqrt{1 - \zeta^2}} \quad (2.138)$$

where ω_d is the damped natural frequency. This is the time period (T) of damped oscillations. If we derive an equation for the values of the peaks, also called the envelope of maximum values, we get:

$$x_{\text{peaks}} = Ae^{-\zeta\omega_n t} \quad (2.139)$$

Knowing that the system is underdamped, A can be solved for using the initial conditions x_0 and v_0 , therefore:

$$A = \frac{\sqrt{(v_0 + \zeta \omega_n x_0)^2 + (x_0 \omega_d)^2}}{\omega_d} \quad (2.140)$$

In terms of t_1 and t_2 , we can express the displacement at these times as:

$$x_1 = A e^{-\zeta \omega_n t_1} \quad (2.141)$$

and

$$x_2 = A e^{-\zeta \omega_n t_2} \quad (2.142)$$

therefore:

$$\frac{x_1}{x_2} = \frac{e^{-\zeta \omega_n t_1}}{e^{-\zeta \omega_n t_2}} = e^{\zeta \omega_n (t_2 - t_1)} \quad (2.143)$$

However, from before we know that $t_2 - t_1 = \frac{2\pi}{\omega_d} = \frac{2\pi}{\omega_n \sqrt{1 - \zeta^2}}$. Therefore, we can express this last equation as:

$$\frac{x_1}{x_2} = e^{\left(\frac{2\pi\zeta}{\sqrt{1 - \zeta^2}} \right)} \quad (2.144)$$

Next, we take the natural log of both sides to get the logarithmic decrement, denoted by δ :

$$\delta = \ln\left(\frac{x_1}{x_2}\right) = \ln\left(\frac{x(t_1)}{x(t_1 + T)}\right) = \frac{2\pi\zeta}{\sqrt{1 - \zeta^2}} \quad (2.145)$$

This shows us that the ratio of any two successive amplitudes for an underdamped system, vibrating freely, is constant and is a function of the damping only. Sometimes, in experiments, it is more convenient/accurate to measure the amplitudes after say “ n ” peaks rather than two successive peaks (because if the damping is very small, the difference between the successive peaks may not be significant). The logarithmic decrement can then be given by the equation

$$\delta = \frac{1}{n} \ln\left(\frac{x_1}{x_{n+1}}\right) = \frac{1}{n} \ln\left(\frac{x(t_1)}{x(t_1 + nT)}\right) = \frac{2\pi\zeta}{\sqrt{1 - \zeta^2}} \quad (2.146)$$

Once we use the experimental data to obtain δ , and knowing that:

$$\delta = \frac{2\pi\zeta}{\sqrt{1 - \zeta^2}} \quad (2.147)$$

we can calculate the value of ζ :

$$\zeta = \frac{\delta}{\sqrt{4\pi^2 + \delta^2}} \quad (2.148)$$

Therefore, having ζ we can solve for the coefficient of damping, c , as:

$$c = \zeta 2\sqrt{km} \quad (2.149)$$

Example 2.9 Experimentally Measuring System Damping

Calculate the damping coefficient for the system with the measured amplitude as expressed below given that $m = 3$ kg and $k = 43$ N/m. Use $t_1 = 1$ sec, and $t_{n+1} = t_4 = 6$ sec. Use the peaks as marked in figure 2.30.

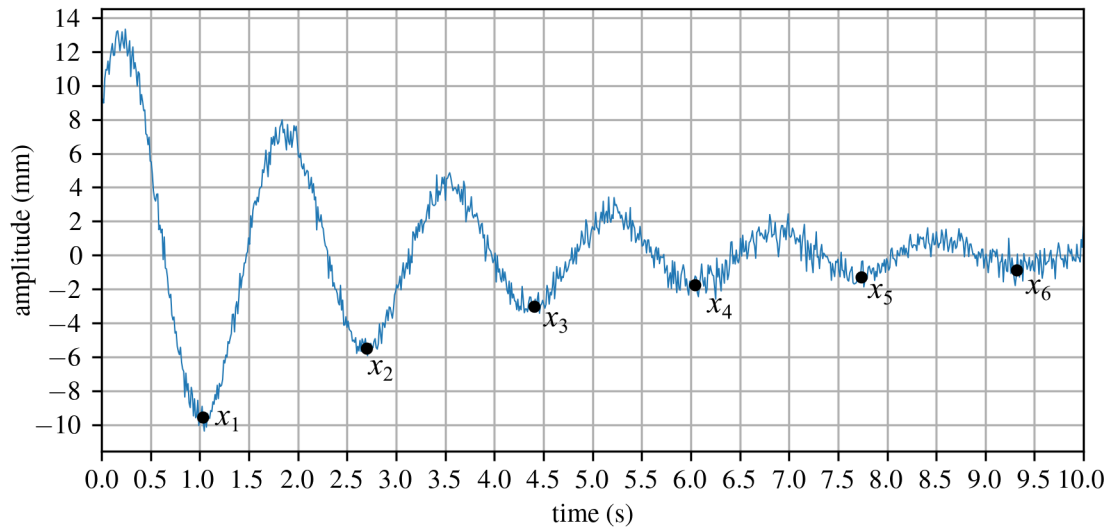

Figure 2.30: Response from an experimental system with noise.

Solution:

First, from the plot we can determine that $x_1 = -9.5$ mm and $x_4 = -1.8$ mm where $n = 3$. Thereafter, we can solve for δ :

$$\delta = \frac{1}{3} \ln \left(\frac{x_1}{x_4} \right) = \frac{1}{3} \ln \left(\frac{-9.5}{-1.8} \right) = 0.554 \quad (2.150)$$

Next, we can calculate ζ , as:

$$\zeta = \frac{\delta}{\sqrt{4\pi^2 + \delta^2}} = \frac{0.554}{\sqrt{4\pi^2 + 0.554^2}} = 0.0879 \quad (2.151)$$

And lastly:

$$c = \zeta 2\sqrt{km} = 0.0879 \cdot 2\sqrt{43 \cdot 3} = 2.0 \text{ kg/s} \quad (2.152)$$

Example 2.10 Calculating Damping Coefficient

The free-response of a 1000-kg automobile with stiffness of $k = 400,000$ N/m is observed to be underdamped. Modeling the automobile as a single-degree-of-freedom oscillation in the vertical direction, as annotated in figure 2.7, determine the damping coefficient if the displacement at t_1 is measured to be 2 cm and 0.22 cm at t_2 .

Solution:

Knowing $x_1 = 2$ cm and $x_2 = 0.22$ cm and $t_2 = T + t_1$, therefore:

$$\delta = \ln \frac{x_1}{x_2} = \ln \frac{2}{0.22} = 2.207 \quad (2.153)$$

and:

$$\zeta = \left(\frac{\delta}{\sqrt{4\pi^2 + \delta^2}} \right) = \left(\frac{2.207}{\sqrt{4\pi^2 + 2.207^2}} \right) = 0.331 \quad (2.154)$$

therefore, we can obtain the damping coefficient as

$$c = 2\zeta \sqrt{km} = 2(0.331) \sqrt{400,000 \cdot 1,000} = 13,256 \text{ kg/s} \quad (2.155)$$

3 Forced Vibrations

Mechanical systems are subjected to external loading. For example, a piston in an engine when forced up and down by a crankshaft or a seat in an airplane may vibrate due to the movement of the jet engines transmitted through the aircraft structure. In real-world situations, structures are subjected to complex loading that are hard to measure or not fully understood.

Vibration Case Study 3.1 Wind Induced Loading

Tall mast light poles are excited by a wind excitation and respond across their entire frequency domain. Consider the light pole located in the state of Kansas in the United States shown figure 3.1. The structure responds more at some frequencies than other frequencies, as dictated by the structure's geometry and material properties. Studying how structures responded to forced inputs allows for a better design of the structure.

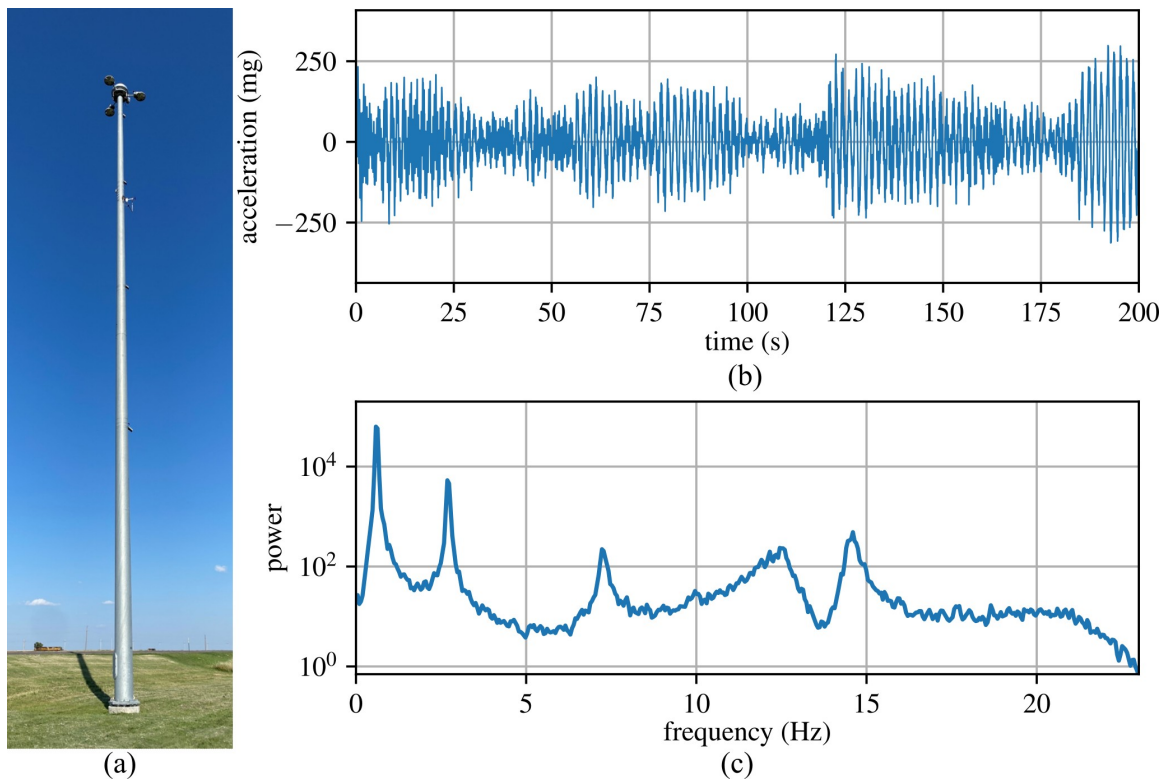

Figure 3.1: Tall mast light pole in the central United States showing: (a) the light mast; (b) the measured temporal response of the light pole, and; (c) the frequency domain response of the light pole. Light pole data provided by Jian li^a and discussed in detail in Shaheen et al.^b.

^aJian li, CC BY-SA 4.0, Light pole data

^bShaheen, Mona, et al. "Wind-Induced Vibration Monitoring of High-Mast Illumination Poles Using Wireless Smart Sensors." *Sensors* 24.8 (2024): 2506.

3.1 Harmonic Excitations of Undamped Systems

Investigating a single-degree of freedom system for a harmonic input is useful as it can be solved mathematically with straightforward techniques. Consider the system:

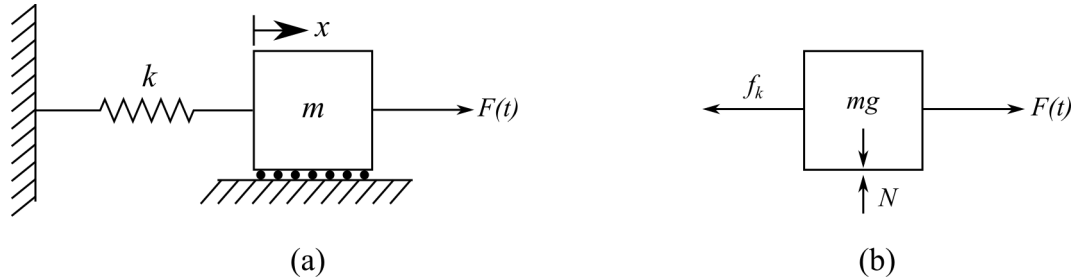

Figure 3.2: 1-DOF system with an external force ($F(t)$) applied, showing: (a) the system configuration; and (b) the free body diagram

where $F(t)$ is the external force applied to the mass. For simplicity, let us consider a harmonic excitation for $F(t)$ such that:

$$F(t) = F_0 \cos(\omega t) \quad (3.1)$$

note that here, ω has no subscript and is the frequency in rad/sec of the driving force. ω is often called the input frequency, driving frequency, or forcing frequency. F_0 represents the magnitude of the applied force. Building the EOM for the system in figure 3.2 yields:

$$m\ddot{x}(t) + kx(t) = F_0 \cos(\omega t) \quad (3.2)$$

For convenience, we drop the “(t)” to make the writing easier. Then, we convert the EOM to the standard form by dividing the equation by m :

$$\ddot{x} + \omega_n^2 x = f_0 \cos(\omega t) \quad (3.3)$$

where:

$$f_0 = \frac{F_0}{m} \quad (3.4)$$

The EOM in this form is a second-order, linear nonhomogeneous differential equation. It is non-homogeneous because there are no terms related to x on the right-hand side of the equation. One way to solve such an ODE is to recall that the solution for a nonhomogeneous equation is the sum of the homogeneous and particular solutions.

$$x = x_h + x_p \quad (3.5)$$

again, noting that this is a temporal solution where “(t)” is implied. First, knowing that the solution is the sum of two parts: 1) oscillations caused by the spring/mass system; and 2) vibrations caused by the forcing function. The oscillations caused by the spring/mass system will form the homogeneous while the vibrations caused by the forcing function will form the particular solution. As we know the solution for oscillations caused by the spring/mass system from our prior investigation of unforced systems we set the equation for the homogeneous solution to be:

$$x_h = A \sin(\omega_n t + \phi) \quad (3.6)$$

Next, we will denote the particular solution as x_p . x_p can be determined by assuming that it is in form of the forcing function, therefore:

$$f_0 \cos(\omega t) \quad (3.7)$$

becomes:

$$x_p = X \cos(\omega t) \quad (3.8)$$

where, x_p is the particular solution and X is the amplitude of the forced response. Our total solution for the harmonic excitations of undamped systems now becomes:

$$x(t) = A \sin(\omega_n t + \phi) + X \cos(\omega t) \quad (3.9)$$

This approach, of assuming that $x_p = X \cos(\omega t)$, in order to determine the particular solution is called the *method of undetermined coefficients*. To calculate X , first we take the equations for x_p and \ddot{x}_p :

$$x_p = X \cos(\omega t) \quad (3.10)$$

$$\ddot{x}_p = -\omega^2 X \cos(\omega t) \quad (3.11)$$

and substituting these into the equation of motion in standard form yields:

$$-\omega^2 X \cos(\omega t) + \omega_n^2 X \cos(\omega t) = f_0 \cos(\omega t) \quad (3.12)$$

As long as $\cos(\omega t) \neq 0$, solving for X yields:

$$X = \frac{f_0}{\omega_n^2 - \omega^2} \quad (3.13)$$

Therefore, as long as $\omega_n \neq \omega$, the particular solution can take the form:

$$x_p = \frac{f_0}{\omega_n^2 - \omega^2} \cos(\omega t) \quad (3.14)$$

This then expands to the total form:

$$x(t) = A \sin(\omega_n t + \phi) + \frac{f_0}{\omega_n^2 - \omega^2} \cos(\omega t) \quad (3.15)$$

Expanding this to the general form for the homogeneous solution obtains the equation:

$$x(t) = A_1 \sin(\omega_n t) + A_2 \cos(\omega_n t) + \frac{f_0}{\omega_n^2 - \omega^2} \cos(\omega t) \quad (3.16)$$

As before, we need to determine the values for the coefficients A_1 and A_2 by enforcing the initial conditions x_0 and v_0 . Setting the time to zero ($t = 0$) and solving the initial displacement leads to:

$$x(0) = x_0 = A_2 + \frac{f_0}{\omega_n^2 - \omega^2} \quad (3.17)$$

or:

$$A_2 = x_0 - \frac{f_0}{\omega_n^2 - \omega^2} \quad (3.18)$$

again, solving the equation in terms of velocity:

$$\dot{x}(t) = A_1 \omega_n \cos(\omega_n t) - A_2 \omega_n \sin(\omega_n t) - \omega \frac{f_0}{\omega_n^2 - \omega^2} \sin(\omega t) \quad (3.19)$$

and solving for the initial velocity at $t = 0$:

$$\dot{x}(0) = v_0 = A_1 \omega_n \quad (3.20)$$

or:

$$A_1 = \frac{v_0}{\omega_n} \quad (3.21)$$

Therefore, combining the equations we get:

$$x(t) = \left(\frac{v_0}{\omega_n} \right) \sin(\omega_n t) + \left(x_0 - \frac{f_0}{\omega_n^2 - \omega^2} \right) \cos(\omega_n t) + \frac{f_0}{\omega_n^2 - \omega^2} \cos(\omega t) \quad (3.22)$$

As before, we can relate A_1 and A_2 to each other through the basic trigonometric identities. This yields,

$$x(t) = A \sin(\omega_n t + \phi) + X \cos(\omega t) \quad (3.23)$$

$$A = \sqrt{\left(\frac{v_0}{\omega_n} \right)^2 + (x_0 - X)^2} \quad (3.24)$$

$$\phi = \tan^{-1} \left(\frac{\omega_n (x_0 - X)}{v_0} \right) \quad (3.25)$$

$$X = \frac{f_0}{\omega_n^2 - \omega^2} \quad (3.26)$$

Example 3.1 Plotting Free and Forced Vibrations

For the 1-DOF system:

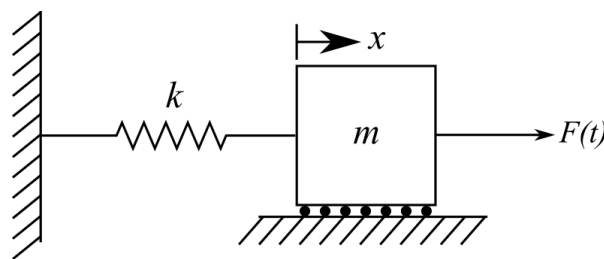

Figure 3.3: 1-DOF spring-mass system subjected to an external force $F(t)$.

with $k = 10$ N/m, $m = 2.5$ kg, $\omega = 4$ rad/sec, $F_0 = 0.1$ N, $x_0 = 1$ mm, and $v_0 = 0$ mm/s plot the temporal responses of the system considering the free-vibration case and the excited case. Plot these on a single plot to compare the responses.

Solution:

The free-vibration response can be plotted using the expression:

$$x(t) = x_0 \cos(\omega_n t) + \frac{v_0}{\omega_n} \sin(\omega_n t) \quad (3.27)$$

while the force vibration is expressed using:

$$x(t) = \left(\frac{v_0}{\omega_n}\right) \sin(\omega_n t) + \left(x_0 - \frac{f_0}{\omega_n^2 - \omega^2}\right) \cos(\omega_n t) + \frac{f_0}{\omega_n^2 - \omega^2} \cos(\omega t) \quad (3.28)$$

These temporal responses are plotted in figure 3.4. Note that the forcing function uses the axis on the right.

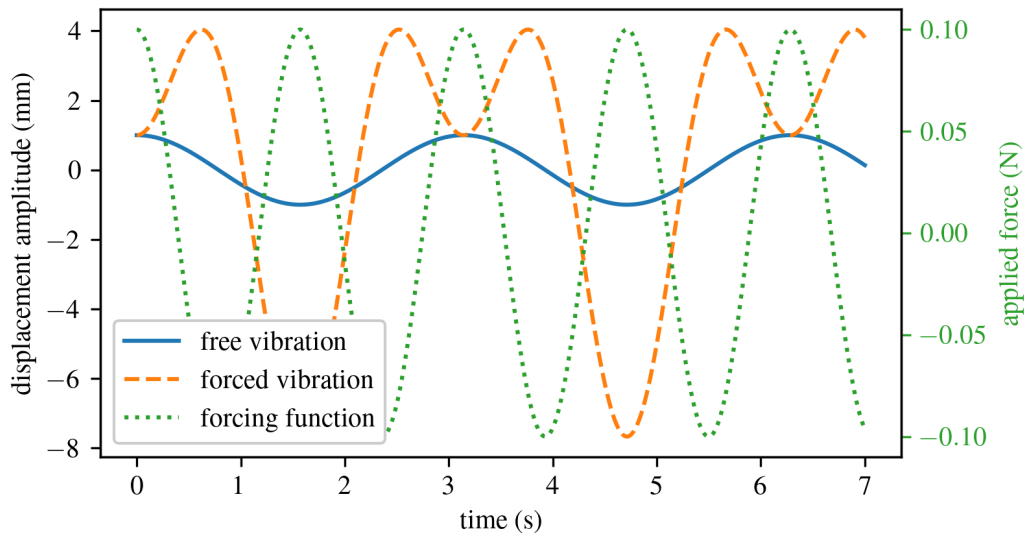

Figure 3.4: Comparison of the temporal response for a 1-DOF system; expressing how the forcing function changes the vibrational temporal response of the system.

3.2 Harmonic Resonance

Recall that our solution from before assumed that $\omega_n \neq \omega$, however, if $\omega_n = \omega$ then the system will develop the phenomenon of resonance. Mathematically, this means the amplitude of the vibrations becomes unbounded. The prior choice of $X \cos(\omega t)$ for the particular solution fails as it is also a solution for a homogeneous equation. Therefore, a new particular solution is needed for the case where $\omega_n = \omega$. This new particular solution can be written as:

$$x_p(t) = tX \sin(\omega t) \quad (3.29)$$

Substituting this into the EOM of the system in standard form equation^a and solving for X yields:

$$x_p(t) = \frac{f_0}{2\omega} t \sin(\omega t) \quad (3.30)$$

^aBoyce, William E., Richard C. DiPrima, and Douglas B. Meade. Elementary differential equations and boundary value problems. John Wiley & Sons, 2021.

thus, the total solution can now be written as:

$$x(t) = A_1 \sin(\omega t) + A_2 \cos(\omega t) + \frac{f_0}{2\omega} t \sin(\omega t) \quad (3.31)$$

Note that $\omega_n = \omega$, therefore, the frequencies are all in terms of the driving frequency ω . Again, evaluating the solution at $t = 0$ for the initial conditions x_0 and v_0 yields:

$$x(t) = \left(\frac{v_0}{\omega}\right) \sin(\omega t) + x_0 \cos(\omega t) + \frac{f_0}{2\omega} t \sin(\omega t) \quad (3.32)$$

Where the first two terms account for the oscillations while the third term accounts for the continued increase of the maximum amplitude. The following plot shows the forced response of a spring-mass system driven harmonically at its natural frequency.

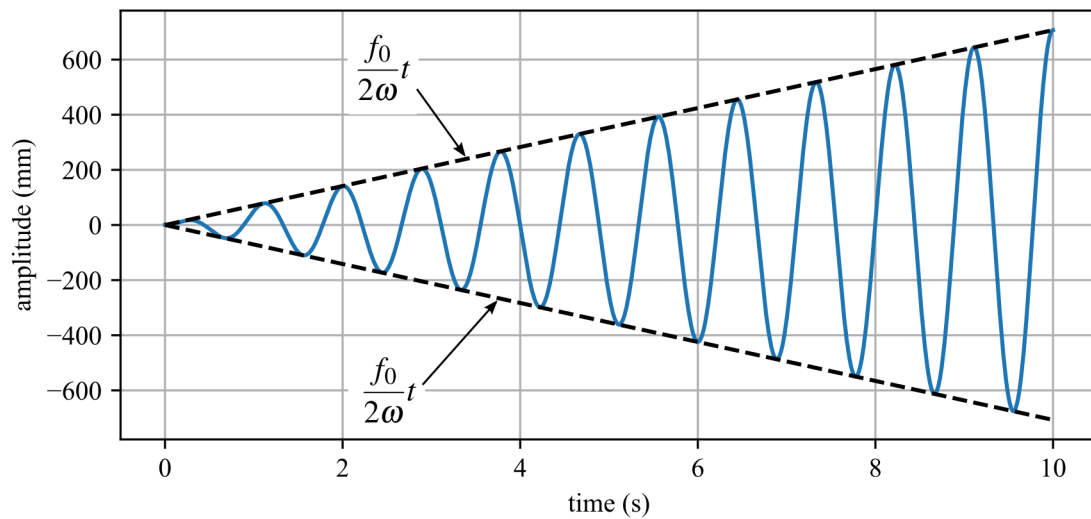

Figure 3.5: Temporal response of a system in resonance showing the enveloped maximum amplitude of displacement.

Example 3.2 Homogeneous and Particular Solution

Compute solutions for the homogeneous and particular solution separately, then compute the total response of a spring-mass system with the following values: $k = 500$ N/m, $m = 10$ kg, subject to a harmonic force of magnitude $F_0 = 100$ N and frequency of 8.162 rad/s, and initial conditions given by $x_0 = 0$ m and $v_0 = 0$ m/s. Plot the response.

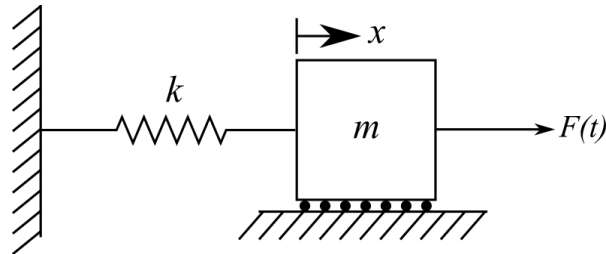

Figure 3.6: 1-DOF spring-mass system subjected to an external force $F(t)$.

Solution:

First, make sure that the system is not in resonance. Calculating that $\omega_n = \sqrt{1000/10} = 10$ shows us that $\omega_n \neq \omega$. Next knowing that $f_0 = F_0/m = 10$ we can find the homogeneous and particular solutions as:

$$x_h(t) = A \sin(\omega_n t + \phi) \quad (3.33)$$

$$x_p(t) = X \cos(\omega t) \quad (3.34)$$

also:

$$x(t) = x_h(t) + x_p(t) \quad (3.35)$$

where:

$$A = \sqrt{\left(\frac{v_0}{\omega_n}\right)^2 + (x_0 - X)^2} = \quad (3.36)$$

$$\phi = \tan^{-1}\left(\frac{\omega_n(x_0 - X)}{v_0}\right) \quad (3.37)$$

$$X = \frac{f_0}{\omega_n^2 - \omega^2} \quad (3.38)$$

This leads to the following results.

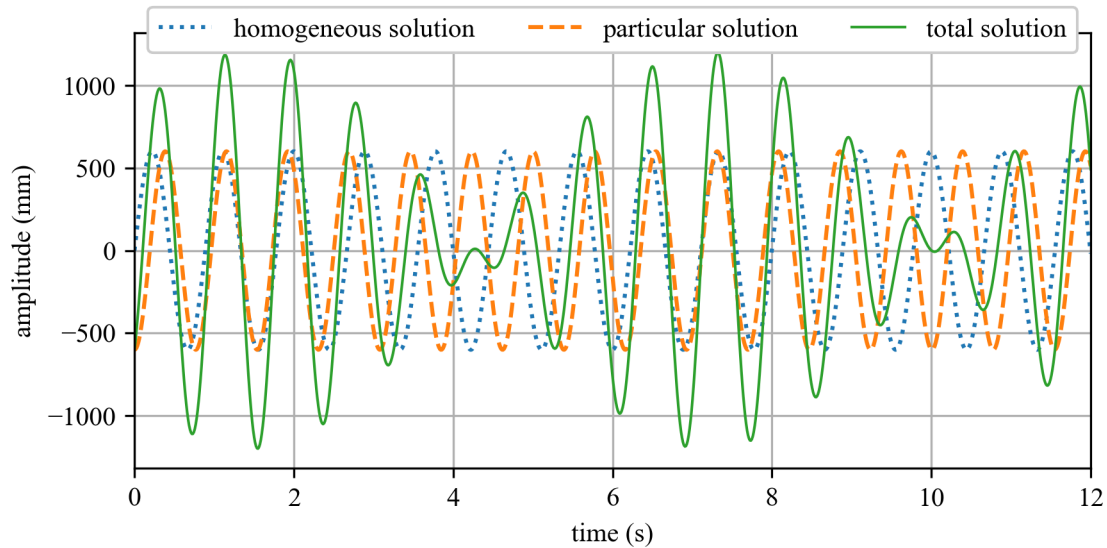

Figure 3.7: Temporal response for example problem where the envelope of the total solution is a “beat” with a period of approximately 6 seconds.

Example 3.3 Forced Undamped System Response

Considering the following system, write the equation of motion and calculate the response assuming a) that the system is initially at rest, and b) that the system has an initial displacement of 0.005 m. Use $k = 2000$ N/m, $m = 100$ kg, $F(t) = 10\sin(10t)$ N.

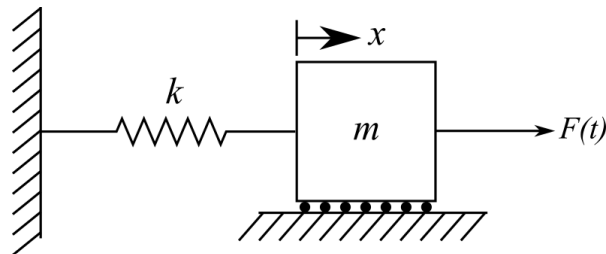

Figure 3.8: 1-DOF spring-mass system subjected to an external force $F(t)$.

Solution:

The equation of motion is

$$m\ddot{x} + kx = 10\sin(10t) \quad (3.39)$$

or in standard form:

$$\ddot{x} + \omega_n^2 x = f_0 \sin(\omega t) \quad (3.40)$$

Note that the forcing function is in terms of sin, not cos as before, so we will have to resolve for the constants A_1 and A_2 . Again, setting the particular solution to $x_p = X\sin(\omega t)$ and solving

for X as before yields:

$$x(t) = A_1 \sin(\omega_n t) + A_2 \cos(\omega_n t) + \frac{f_0}{\omega_n^2 - \omega^2} \sin(\omega t) \quad (3.41)$$

Now we can solve for A_1 and A_2 by setting the initial conditions x_0 and v_0 to $t = 0$. First, setting $t = 0$ in the equation for $x(t)$ yields:

$$A_2 = x_0 \quad (3.42)$$

Then, a function for the velocity of the system is obtained:

$$\dot{x}(t) = v_0 = A_1 \omega_n \cos(\omega_n t) - A_2 \omega_n \sin(\omega_n t) + \omega \frac{f_0}{\omega_n^2 - \omega^2} \cos(\omega t) \quad (3.43)$$

This allows us to obtain:

$$A_1 = \frac{v_0}{\omega_n} - \frac{\omega}{\omega_n} \cdot \frac{f_0}{\omega_n^2 - \omega^2} \quad (3.44)$$

at $t = 0$. These lead to the full equation for the general solution:

$$x(t) = \left(\frac{v_0}{\omega_n} - \frac{\omega}{\omega_n} \cdot \frac{f_0}{\omega_n^2 - \omega^2} \right) \sin(\omega_n t) + x_0 \cos(\omega_n t) + \frac{f_0}{\omega_n^2 - \omega^2} \sin(\omega t) \quad (3.45)$$

Also, knowing:

$$\omega_n = \sqrt{\frac{k}{m}} = \sqrt{20} \text{ rad/sec} = 4.472 \text{ rad/sec} \quad (3.46)$$

and

$$f_0 = \frac{F_0}{m} = \frac{F_0}{m} = 0.1 \text{ N/kg} \quad (3.47)$$

Solution a):

Using the initial conditions $x_0 = 0$ m and $v_0 = 0$ m/s and the general expression obtained above:

$$x(t) = \left(0 - \frac{10}{\sqrt{20}} \cdot \frac{0.1}{20 - 10^2} \right) \sin(\sqrt{20}t) + 0 + \frac{0.1}{20 - 10^2} \sin(10t) \quad (3.48)$$

Solution b):

Using the initial conditions $x_0 = 0.005$ m and $v_0 = 0$ m/s and the general expression obtained above:

$$x(t) = \left(0 - \frac{10}{\sqrt{20}} \cdot \frac{0.1}{20 - 10^2} \right) \sin(\sqrt{20}t) + 0.05 \cos(\sqrt{20}t) + \frac{0.1}{20 - 10^2} \sin(10t) \quad (3.49)$$

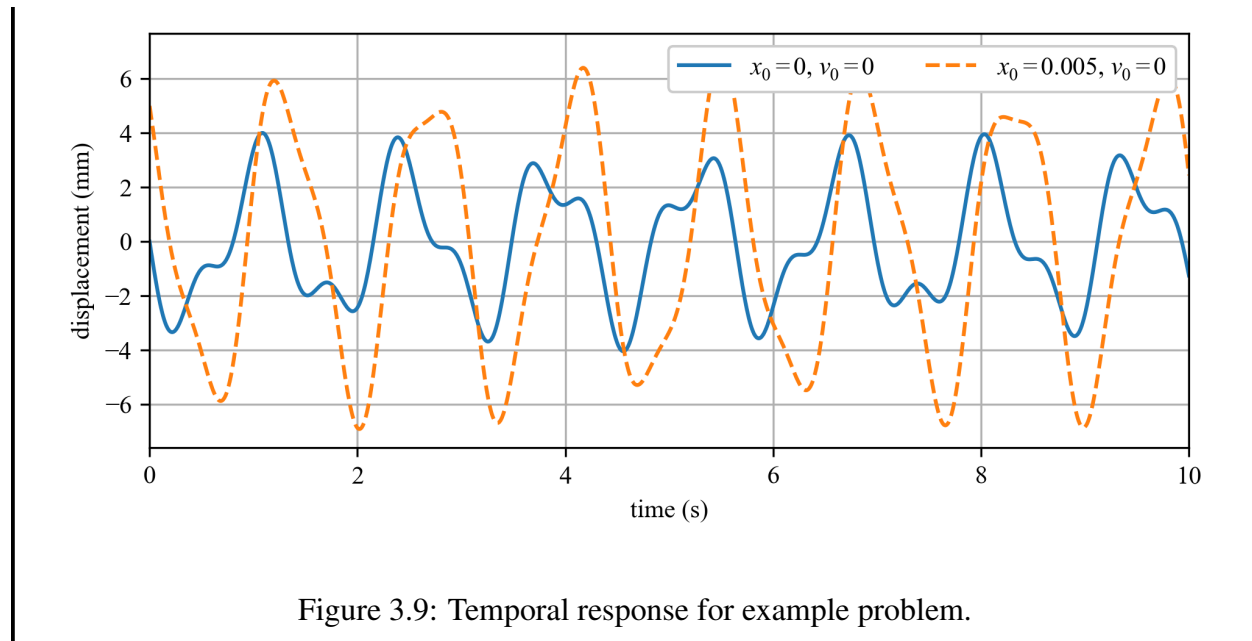

Figure 3.9: Temporal response for example problem.

Vibration Case Study 3.2 Bio-dynamic Induced Loading

The Millennium Bridge is a pedestrian suspension bridge in London over the River Thames. The supporting cables of the bridge are abnormally low and rest below the deck level, giving a very shallow profile. This was required by London's protected Vistas which necessitates a clear line of view from Alexandra Palace to Saint Paul's Cathedral; as well as behind Saint Paul's Cathedral where the bridge sits.

When opened on 10 June 2000, 2,000 pedestrians at 1.5 people per square meter used the bridge. The bridge started to rock in the lateral direction at frequencies of between 0.5 Hz and 1.1 Hz with accelerations up to $0.25 g_n$, this caused people on the bridge to try and brace themselves by moving their body mass in sync with the bridge's movement. This bio-dynamic coupling created a forced lateral vibration in the bridge that would persist when sufficient people were on the bridge.

To mitigate the vibrations, 37 dampers of 7 different types were installed to control the lateral modes, with some also controlling vertical and torsional modes. After the installation of dampers, peak measured accelerations from $0.25 g_n$ to $0.006 g_n$ and no observable bio-dynamic feedback occurred. In total, this retrofit took almost 2 years and added an extra £5 million to the initial £18.2 million cost of the bridge.

Figure 3.10: View of Millennium Bridge in London UK^a.

^aDavid Martin / Under the Millennium Bridge / CC BY-SA 2.0

3.3 Harmonic Excitations of Underdamped Systems

Consider the system:

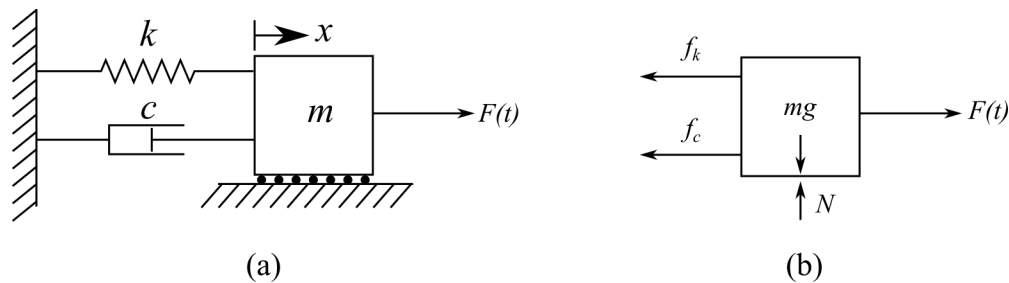

Figure 3.11: Damped 1-DOF system with an external force ($F(t)$) applied, showing: (a) the system configuration; and (b) the free body diagram

Again, for simplicity, let us consider a harmonic excitation for $F(t)$ such that:

$$F(t) = F_0 \cos(\omega t) \quad (3.50)$$

Building the EOM for the system in figure 3.11 results in:

$$m\ddot{x}(t) + c\dot{x}(t) + kx(t) = F_0 \cos(\omega t) \quad (3.51)$$

For convinces we can convert this to the standard form:

$$\ddot{x}(t) + 2\zeta\omega_n\dot{x}(t) + \omega_n^2x(t) = f_0 \cos(\omega t) \quad (3.52)$$

again, where:

$$f_0 = \frac{F_0}{m} \quad (3.53)$$

Recall that one way to solve such an equation is to obtain the sum of the homogeneous and particular solutions.

$$x(t) = x_h(t) + x_p(t) \quad (3.54)$$

However, now that we have damping force to consider, our particular solution will have to consider this damping. Therefore:

$$x_p(t) = X \cos(\omega t - \phi_p) \quad (3.55)$$

where ϕ_p represents the phase shift.

NOTE

ϕ_p is represented in other texts as θ , θ_p , or even just ϕ but we will use ϕ_p throughout the remainder of this text.

Again, the phase shift is expected because of the effect of the damping force. Now, our total equation is:

$$x(t) = A e^{-\zeta \omega_n t} \sin(\omega_d t + \phi) + X \cos(\omega t - \phi_p) \quad (3.56)$$

We can use the method of undetermined coefficients to obtain X and ϕ_p for the particular solution. First, considering that we write the particular solution in the equivalent form:

$$x_p(t) = X \cos(\omega t - \phi_p) = A_s \cos(\omega t) + B_s \sin(\omega t) \quad (3.57)$$

Taking the derivative of the assumed forms of the particular solution yields:

$$x_p(t) = A_s \cos(\omega t) + B_s \sin(\omega t) \quad (3.58)$$

$$\dot{x}_p(t) = -\omega A_s \sin(\omega t) + \omega B_s \cos(\omega t) \quad (3.59)$$

$$\ddot{x}_p(t) = -\omega^2 A_s \cos(\omega t) - \omega^2 B_s \sin(\omega t) \quad (3.60)$$

Recall that the homogeneous and particular solutions are each solutions on their own, therefore, the EOM can be used to describe just the particular solution. Substituting x_p , \dot{x}_p , and \ddot{x}_p for x , \dot{x} , and \ddot{x} in the EOM in standard form:

$$\ddot{x} + 2\zeta \omega_n \dot{x} + \omega_n^2 x = f_0 \cos(\omega t) \quad (3.61)$$

yields:

$$(-\omega^2 A_s \cos(\omega t) - \omega^2 B_s \sin(\omega t)) + 2\zeta \omega_n (-\omega A_s \sin(\omega t) + \omega B_s \cos(\omega t)) + \quad (3.62)$$

$$\omega_n^2 (A_s \cos(\omega t) + B_s \sin(\omega t)) = f_0 \cos(\omega t)$$

and rearranging in terms of $\sin(\omega t)$ and $\cos(\omega t)$ yields:

$$(-\omega^2 A_s + 2\zeta \omega_n \omega B_s + \omega_n^2 A_s - f_0) \cos(\omega t) + \quad (3.63)$$

$$(-\omega^2 B_s - 2\zeta \omega_n \omega A_s + \omega_n^2 B_s) \sin(\omega t) = 0$$

From this expression, it is clear that there are two special moments in time where $\cos(\omega t)$ and $\sin(\omega t)$ equal zero. First, considering that $t = \pi/(2\omega)$ results in $\cos(\omega t)=0$, $\sin(\omega t)=1$ and the equation simplifies to:

$$(-2\zeta\omega_n\omega)A_s + (\omega_n^2 - \omega^2)B_s = 0 \quad (3.64)$$

Additionally, at $t = 0$, $\sin(\omega t)=0$ and $\cos(\omega t)=1$. Therefore, the equation yields

$$(\omega_n^2 - \omega^2)A_s + (2\zeta\omega_n\omega)B_s = f_0 \quad (3.65)$$

We can solve two equations for two unknowns. Writing the two linear equations as the singular matrix equation yields:

$$\begin{bmatrix} \omega_n^2 - \omega^2 & 2\zeta\omega_n\omega \\ -2\zeta\omega_n\omega & \omega_n^2 - \omega^2 \end{bmatrix} \begin{bmatrix} A_s \\ B_s \end{bmatrix} = \begin{bmatrix} f_0 \\ 0 \end{bmatrix} \quad (3.66)$$

This can be solved by computing this system of equations for $\begin{bmatrix} A_s \\ B_s \end{bmatrix}$. This gives us:

$$A_s = \frac{(\omega_n^2 - \omega^2)f_0}{(\omega_n^2 - \omega^2)^2 + (2\zeta\omega_n\omega)^2} \quad (3.67)$$

$$B_s = \frac{2\zeta\omega_n\omega f_0}{(\omega_n^2 - \omega^2)^2 + (2\zeta\omega_n\omega)^2} \quad (3.68)$$

From trigonometric relationships we can see that,

$$X = \sqrt{A_s^2 + B_s^2} \quad (3.69)$$

$$\phi_p = \tan^{-1} \left(\frac{B_s}{A_s} \right) \quad (3.70)$$

We can now derive values for our particular solution x_p :

$$X = \frac{f_0}{\sqrt{(\omega_n^2 - \omega^2)^2 + (2\zeta\omega_n\omega)^2}} \quad (3.71)$$

$$\phi_p = \tan^{-1} \left(\frac{2\zeta\omega_n\omega}{\omega_n^2 - \omega^2} \right) \quad (3.72)$$

Now we can build a solution for the particular equation (x_p), therefore, the total solution becomes:

$$x(t) = x_h(t) + x_p(t) \quad (3.73)$$

$$x(t) = Ae^{-\zeta\omega_n t} \sin(\omega_d t + \phi) + X \cos(\omega t - \phi_p) \quad (3.74)$$

NOTE

For larger values of t , the homogeneous solution approaches zero resulting in the particular solution becoming the total solution. Therefore, the particular solution is sometimes called the steady-state response, and the homogeneous solution is called the transient response.

Solving for the constants A and ϕ using boundary conditions ($x_0 = 0$ and $v_0 = 0$) results in a total solution expressed as:

$$A = \frac{x_0 - X \cos(\phi_p)}{\sin(\phi)} \quad (3.75)$$

$$\phi = \tan^{-1} \left(\frac{\omega_d (x_0 - X \cos(\phi_p))}{v_0 + (x_0 - X \cos(\phi_p)) \zeta \omega_n - \omega X \sin(\phi_p)} \right) \quad (3.76)$$

Assembling all the terms solved results in a unified solution:

$$x(t) = A e^{-\zeta \omega_n t} \sin(\omega_d t + \phi) + X \cos(\omega t - \phi_p) \quad (3.77)$$

Where the parameters are defined as:

$$A = \frac{x_0 - X \cos(\phi_p)}{\sin(\phi)} \quad (3.78)$$

$$\phi = \tan^{-1} \left(\frac{\omega_d (x_0 - X \cos(\phi_p))}{v_0 + (x_0 - X \cos(\phi_p)) \zeta \omega_n - \omega X \sin(\phi_p)} \right) \quad (3.79)$$

$$X = \frac{f_0}{\sqrt{(\omega_n^2 - \omega^2)^2 + (2\zeta \omega_n \omega)^2}} \quad (3.80)$$

$$\phi_p = \tan^{-1} \left(\frac{2\zeta \omega_n \omega}{\omega_n^2 - \omega^2} \right) \quad (3.81)$$

Note that for a case where damping equals zero, this expression collapses down to that obtained for a undamped system.

Example 3.4 Plotting Steady State and Transient Responses

Consider the damped 1-DOF system below, and plot the total, steady state, and transient responses for the following system configurations with no initial conditions. For each configuration, comment on the temporal response and how it differs from the response of the previous configuration.

- $k = 100$ N/m, $m = 10$ kg, $c = 10$ kg/s, $F_0 = 1$ N, and $\omega = 8.162$ rad/s.
- $k = 100$ N/m, $m = 10$ kg, $c = 10$ kg/s, $F_0 = 3$ N, and $\omega = 8.162$ rad/s.
- $k = 100$ N/m, $m = 10$ kg, $c = 10$ kg/s, $F_0 = 3$ N, and $\omega = 3.162$ rad/s.

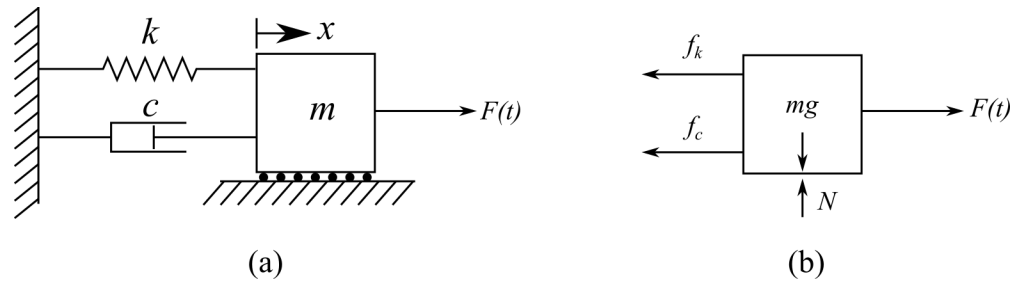

Figure 3.12: Damped 1-DOF system with an external force ($F(t)$) applied, showing: (a) the system configuration; and (b) the free body diagram

Solution:

The total response for the damped 1-DOF system subjected to an external force is modeled using equations 3.77 through 3.81 while the transient response consists of the first half of equation 3.77 and the steady state response consists of the second half of equation 3.77.

Solution a):

Therefore, plotting the temporal responses for the configuration yields:

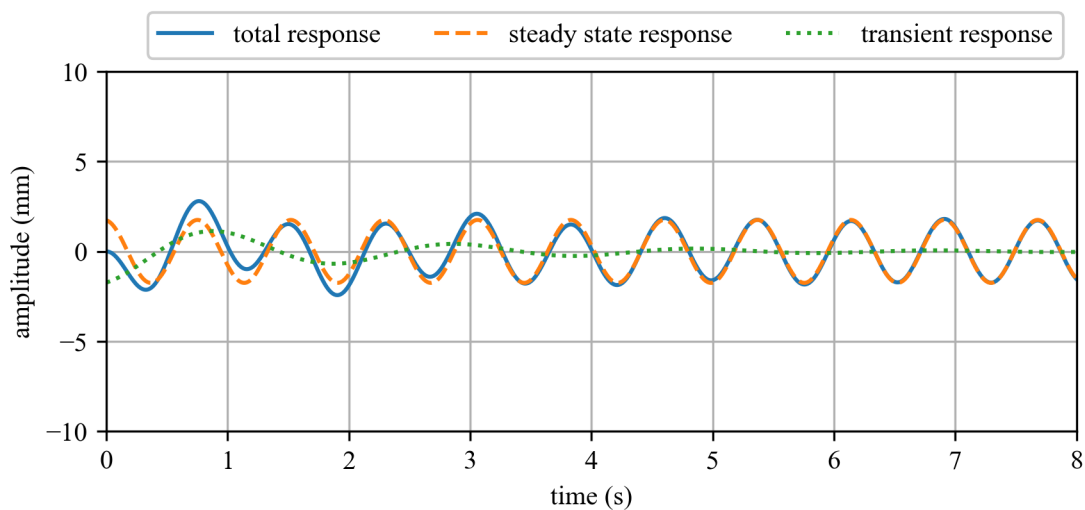

Figure 3.13: Temporal responses for a underdamped system with $k = 100$ N/m, $m = 10$ kg, $c = 10$ kg/s, $F_0 = 1$ N, and $\omega = 8.162$ rad/s.

Solution b): Configuration b increases the forcing function F_0 to 3 N. This results in a similar response to configuration a but with a linearly scaled amplitude:

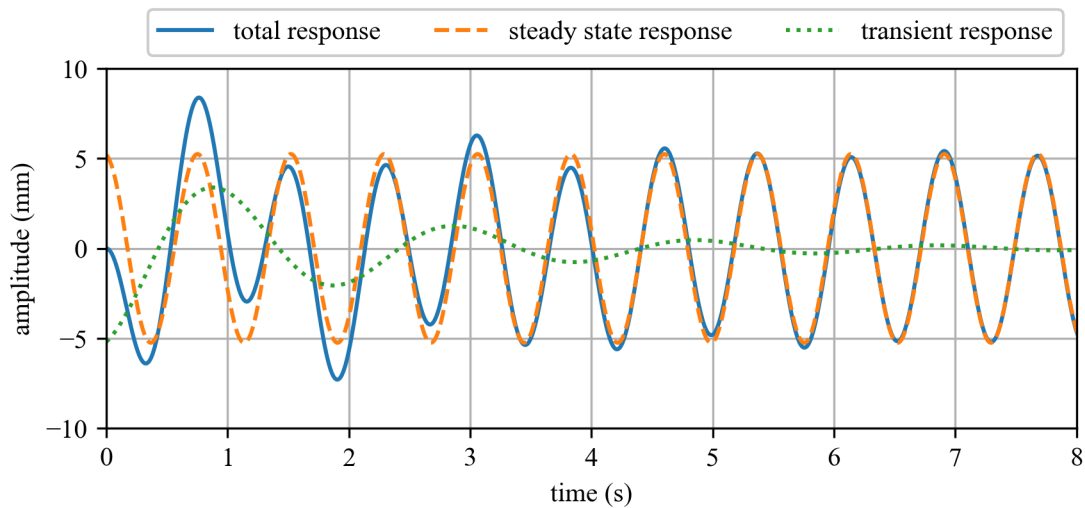

Figure 3.14: Temporal responses for a underdamped system with $k = 100$ N/m, $m = 10$ kg, $c = 10$ kg/s, $F_0 = 3$ N, and $\omega = 8.162$ rad/s.

Solution c):

Now, using $\omega = 3.162$ rad/sec we put the system into resonance as $\omega = \omega_n$. However, unlike the undamped system, the amplitude of the displacement is not unbounded as the damper absorbs energy from the system. Therefore, after about 7 seconds the system enters an equilibrium state where any additional increase in amplitude caused by the system entering into resonance is canceled out by the damping in the system as demonstrated in the plot below:

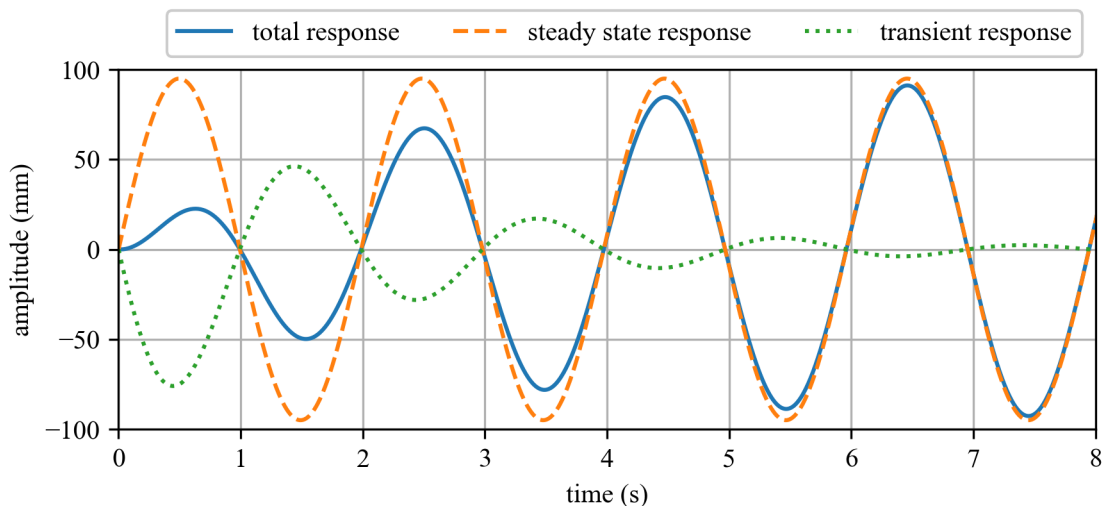

Figure 3.15: Temporal responses for a underdamped system with $k = 100$ N/m, $m = 10$ kg, $c = 10$ kg/s, $F_0 = 3$ N, and $\omega = 3.162$.

3.4 Frequency Response of Underdamped Systems

From equations 3.77 through 3.81 and the figures in example 3.4 we can see that for larger values of t the transient response dies out while only the steady-state response controls the displacement of the total response. This is always true if the system has any significant damping. Therefore, it is often prudent to ignore the transient part and focus only on the steady-state response. Considering the equation for the particular solution:

$$x_p(t) = X \cos(\omega t - \phi_p) \quad (3.82)$$

and knowing the values for X and ϕ_p :

$$X = \frac{f_0}{\sqrt{(\omega_n^2 - \omega^2)^2 + (2\zeta \omega_n \omega)^2}} \quad (3.83)$$

$$\phi_p = \tan^{-1} \left(\frac{2\zeta \omega_n \omega}{\omega_n^2 - \omega^2} \right) \quad (3.84)$$

We want to find a way to plot the responses of the system only in terms of the system's natural and driving frequencies, and its damping. First, we define a frequency ratio as the dimensionless quantity

$$r = \frac{\omega}{\omega_n} \quad (3.85)$$

Another common way to express r is β . Next, Recall that:

$$X = \frac{f_0}{\sqrt{(\omega_n^2 - \omega^2)^2 + (2\zeta \omega_n \omega)^2}} = \frac{\frac{F_0}{m}}{\sqrt{(\omega_n^2 - \omega^2)^2 + (2\zeta \omega_n \omega)^2}} \quad (3.86)$$

If we factor out ω_n^2 from the denominator and substitute in $\omega_n^2 = k/m$ and $r = \omega/\omega_n$, we get:

$$X = \frac{\frac{F_0}{m}}{\omega_n^2 \sqrt{(1 - (\frac{\omega}{\omega_n})^2)^2 + (2\zeta \frac{\omega}{\omega_n})^2}} = \frac{\frac{F_0}{k}}{\sqrt{(1 - r^2)^2 + (2\zeta r)^2}} \quad (3.87)$$

this becomes:

$$\frac{Xk}{F_0} = \frac{X \omega_n^2}{f_0} = \frac{1}{\sqrt{(1 - r^2)^2 + (2\zeta r)^2}} \quad (3.88)$$

in a similar fashion, if we manipulate the equation for ϕ_p we can get ϕ_p in terms of r :

$$\phi_p = \tan^{-1} \left(\frac{2\zeta r}{1 - r^2} \right) \quad (3.89)$$

If we solve for a few key values of r we can get the following data points. On the board, we can solve for a few different frequency responses for a few different damping coefficients.

	frequency ratio (r)								
	0	0.25	0.5	0.75	1	1.25	1.5	1.75	2.0
$\zeta = 0.1$	1.00	1.07	1.32	2.16	5.00	1.62	0.78	0.48	0.33
$\zeta = 0.25$	1.00	1.06	1.27	1.74	2.00	1.19	0.69	0.45	0.32
$\zeta = 0.5$	1.00	1.03	1.11	1.15	1.00	0.73	0.51	0.37	0.28
$\zeta = 0.7$	1.00	1.00	0.97	0.88	0.71	0.54	0.41	0.31	0.24

If we plot the values of the normalized amplitude vs r we obtain figure 3.16 where it can be seen that the normalized amplitude is a function of damping in the system. However, it should be noted that damping is only effective around resonance. Below and above resonance, all damping cases converge on similar values. Note that $\zeta \geq 1/\sqrt{2}$ is the changeover point from where the max normalized displacement is at $r = 0$ vs around resonance.

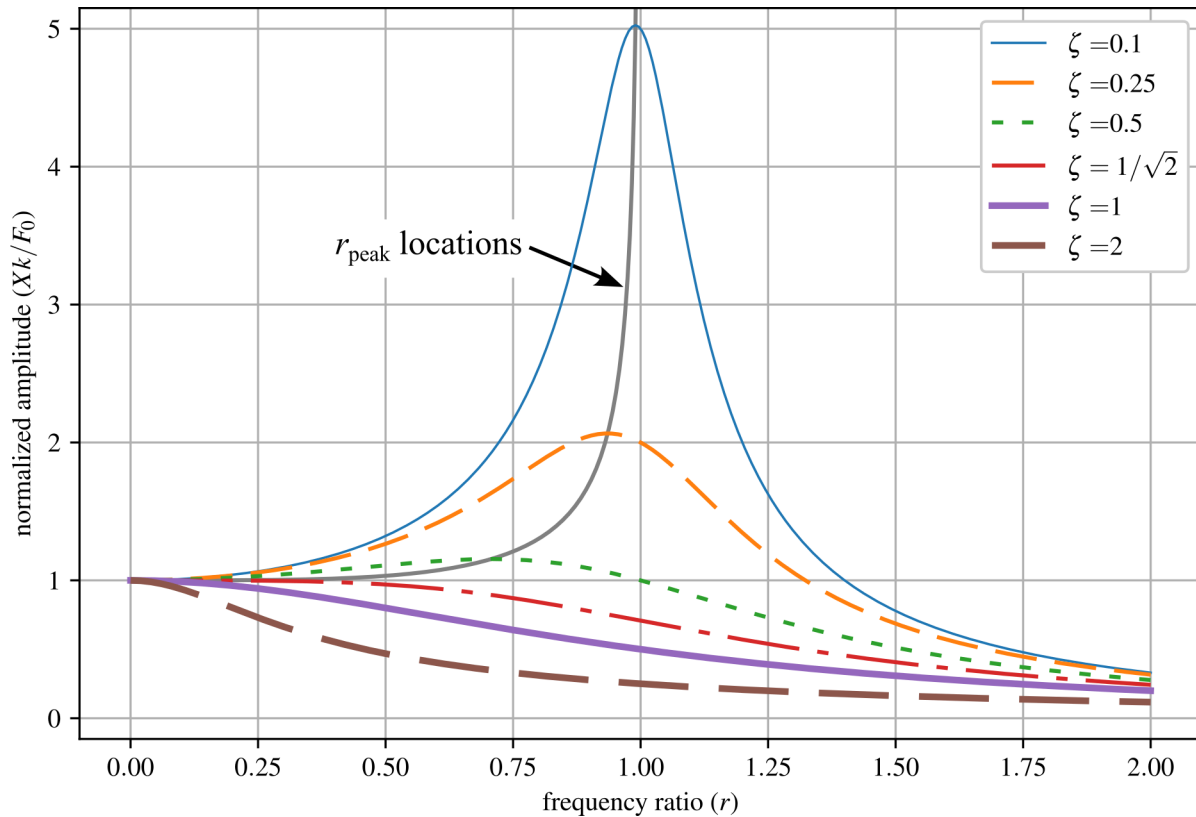

Figure 3.16: Normalized amplitude response for frequency ratio ($r = (\omega/\omega_n)$) from 0 to 2 for a variety of critical damping ratios.

And again, if we plot the values of the phase vs r we get figure 3.17. Note that all systems pass through 90° at resonance. This means that when a system is under resonance, the position of the system will lag the input force by 90° . This phase lag is also called quadrature as the system lags the input by 90° at resonance.

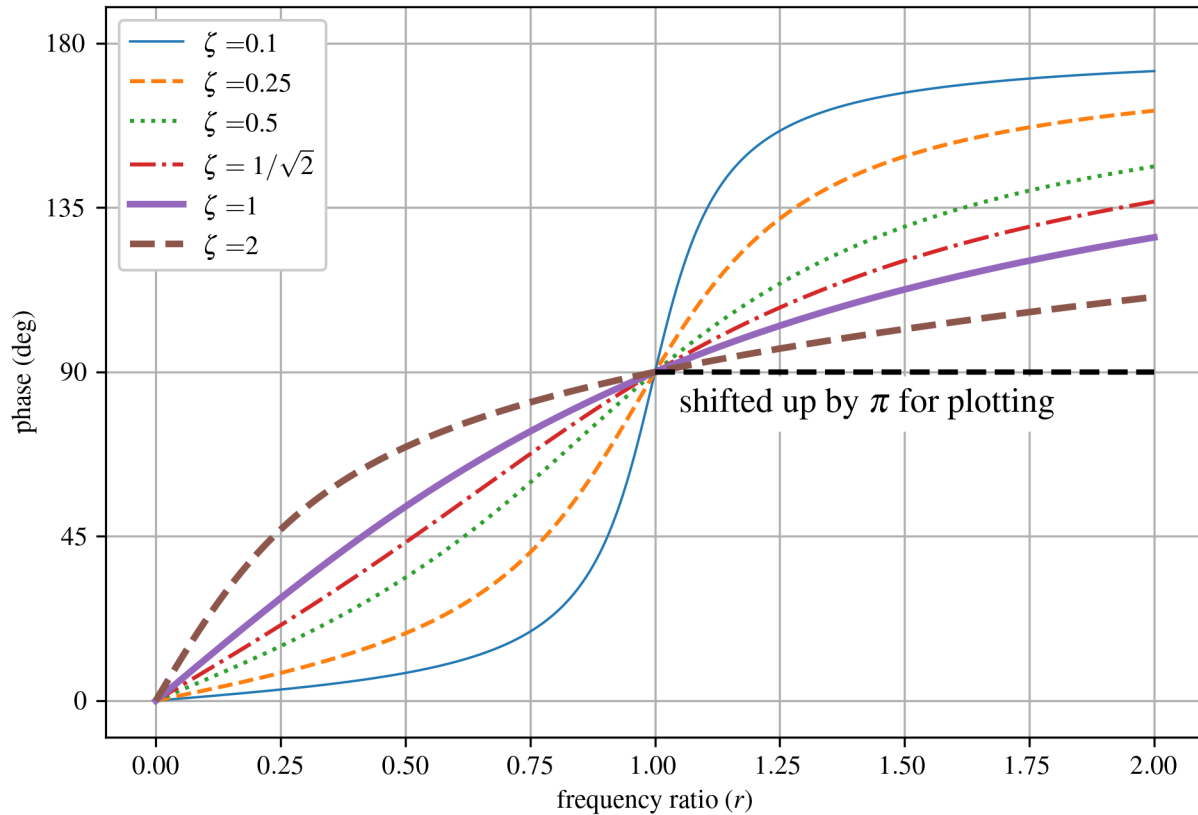

Figure 3.17: Phase response for frequency ratio (r) from 0 to 2 for a variety of critical damping ratios.

note that the dashed black line is there because the phase values after $\pi/2$ need to be adjusted to obtain a continuous plot. An astute observer would notice that the maximum amplitude is not at $\omega = \omega_n$. While resonance is defined as $\omega = \omega_n$, this does not define the point of maximum displacement of the steady-state response. Let us solve for the frequency ratio with the maximum displacement. This will happen when

$$\frac{d}{dr} \left(\frac{Xk}{F_0} \right) = 0 \quad (3.90)$$

We can show that:

$$\left(\frac{1}{\sqrt{(1-r^2)^2 + (2\zeta r)^2}} \right) \frac{d}{dr} = 0 \quad (3.91)$$

when

$$r_{\text{peak}} = \sqrt{1 - 2\zeta^2} = \frac{\omega_p}{\omega_n}, \quad \zeta < 1/\sqrt{2} \quad (3.92)$$

however, this is only true for underdamped systems in which $\zeta < 1/\sqrt{2}$. If $\zeta \geq 1/\sqrt{2}$ then the value is imaginary and the peak value is at $r = 0$. In these cases, the maximum displacement

is a function of only ω_n . ω_p represents the driving frequency that corresponds to the maximum amplitude ($\frac{Xk}{F_0}$) and is called the peak frequency, and can be calculated as:

$$\omega_p = \omega_n r_{\text{peak}} = \omega_n \sqrt{1 - 2\zeta^2}, \quad \zeta < 1/\sqrt{2} \quad (3.93)$$

Example 3.5 Steady State Displacement

Consider the simple spring-mass system,

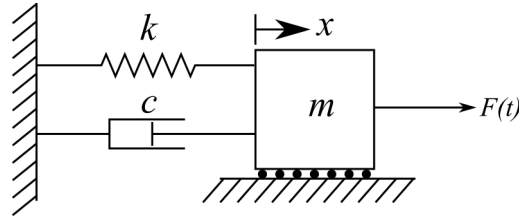

Figure 3.18: Damped 1-DOF spring-mass system subjected to an external force $F(t)$.

where $\omega_n = 132$ rad/sec and $\zeta = 0.0085$. Calculate the displacements of the steady-state response for $\omega=132$ and 125 rad/sec. In both cases, use $f_0 = 10$ N/kg.

Solution:

From before, we know the solution for the system's displacement of the particular solution for $\omega=132$ rad/sec is:

$$X = \frac{f_0}{\sqrt{(\omega_n^2 - \omega^2)^2 + (2\zeta\omega_n\omega)^2}} = \frac{10}{2(0.0085)(132)^2} = 0.034 \text{ m} \quad (3.94)$$

while for $\omega=125$ rad/sec X is:

$$X = \frac{f_0}{\sqrt{(\omega_n^2 - \omega^2)^2 + (2\zeta\omega_n\omega)^2}} = \frac{10}{\sqrt{(1799)^2 + (280.5)^2}} = 0.005 \text{ m} \quad (3.95)$$

Therefore, a slight change in the driving frequency (about 5%) results in an 85% change in the amplitude of the steady-state response.

Example 3.6 Displacement-limited System Design

The steady-state response for an engineered system must not surpass 1 cm, if the system can be modeled as the spring and mass system below, what value of c must be used?

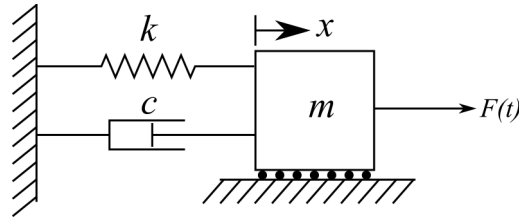

Figure 3.19: Damped 1-DOF spring-mass system subjected to an external force $F(t)$.

Use $k = 2000$ N/m, $m = 100$ kg, $F(t) = 20 \cos(6.3t)$ N.

Solution:

The steady state solution is:

$$x_p(t) = X \cos(\omega t - \phi_p) \quad (3.96)$$

knowing the amplitude is controlled by X :

$$X = \frac{f_0}{\sqrt{(\omega_n^2 - \omega^2)^2 + (2\zeta \omega_n \omega)^2}} \quad (3.97)$$

and recalling from the EOM in standard form that $2\zeta \omega_n = c/m$ we can obtain:

$$X = \frac{f_0}{\sqrt{(\omega_n^2 - \omega^2)^2 + (\frac{c}{m} \omega)^2}} \quad (3.98)$$

rearranging for c gives:

$$c = m \sqrt{\frac{f_0^2}{\omega^2 X^2} - \frac{(\omega_n^2 - \omega^2)^2}{\omega^2}} = \sqrt{\frac{F_0^2}{\omega^2 X^2} - m^2 \frac{(\omega_n^2 - \omega^2)^2}{\omega^2}} \quad (3.99)$$

Therefore, if we set $X = 0.01$ m we can solve the above equation to yield $c = 55.7$ kg/s.

3.5 Base Excitation

Often, loading is not applied directly to the mass, but rather the mass of the system is excited when the base of the mount that it is attached to is excited. This is called base excitation or sometimes support motion. Examples of base excitation, or where base excitation is considered, include:

- machines on rubber mounts
- automobiles excited by the road
- building under earthquake loading
- hospital equipment

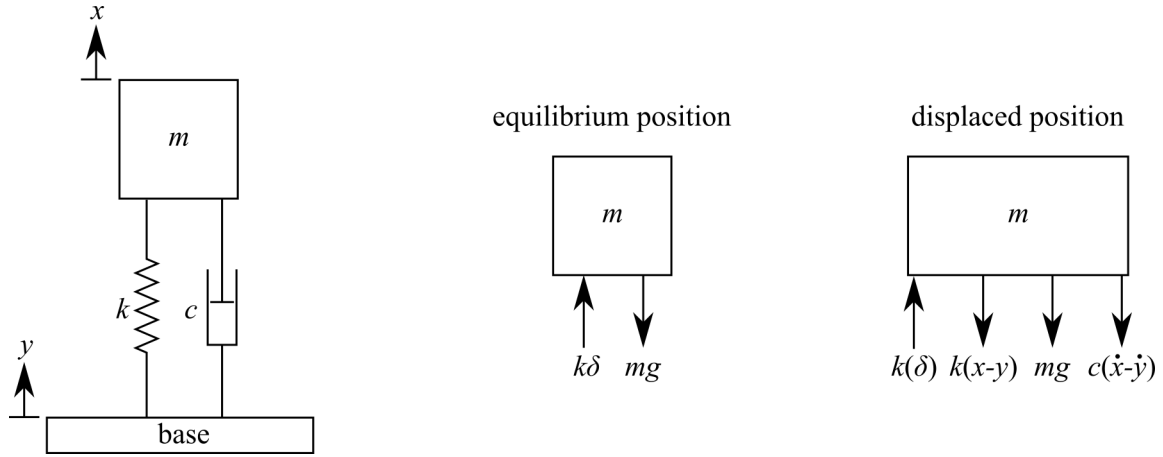

Figure 3.20: Damped 1-DOF spring-mass system subjected to a displacement controlled base excitation showing the FBDs for the equilibrium and displaced positions.

Consider the following system base excited system shown in figure 3.20 where x is the displacement of the mass and y is the displacement of the base. Note that we consider positive upward here so both x and y displace in the same direction. The EOM can be constructed the same as before, but now considering that the relative displacement of the spring and damper is $x - y$.

In the equilibrium state, where a positive x is up and the base displaces down:

$$+\uparrow \sum F_x = k\delta - mg = 0 \quad (3.100)$$

Conversely, the equation for the displaced state is:

$$+\uparrow \sum F_x = k\delta - k(x - y) - mg - c(\dot{x} - \dot{y}) \quad (3.101)$$

Apply Newton's second law about the mass of motion to the sum of forces for the displaced position we get:

$$+\uparrow \sum F_x = m\ddot{x} = k\delta - kx + ky - mg - c\dot{x} + c\dot{y} \quad (3.102)$$

applying the equation $k\delta - mg = 0$, and rearrange into the EOM yields:

$$m\ddot{x} + c\dot{x} + kx = c\dot{y} + ky \quad (3.103)$$

As before we assume an input for the base excitation. For simplicity, we assume:

$$y(t) = Y \sin(\omega_b t) \quad (3.104)$$

Taking the derivative of the assumed input yields:

$$\dot{y}(t) = Y \omega_b \cos(\omega_b t) \quad (3.105)$$

where Y is the amplitude and ω_b is the frequency of the base excitation. Adding these terms into our EOM yields:

$$m\ddot{x} + c\dot{x} + kx = cY \omega_b \cos(\omega_b t) + kY \sin(\omega_b t) \quad (3.106)$$

We can get this in standard form if we divide by m and apply the equations for the critical damping ratio and natural frequency:

$$\ddot{x} + 2\zeta\omega_n\dot{x} + \omega_n^2x = 2\zeta\omega_n\omega_bY\cos(\omega_bt) + \omega_n^2Y\sin(\omega_bt) \quad (3.107)$$

This equation can be related to a spring-mass-damper system with two harmonic inputs, one cos, and one sin as shown below:

$$\ddot{x} + 2\zeta\omega_n\dot{x} + \omega_n^2x = C\cos(\omega_bt) + D\sin(\omega_bt) \quad (3.108)$$

where C and D are arbitrary coefficients.

Vibration Case Study 3.3 Structural Health Monitoring during Earthquakes

Earthquakes are a classic and devastating example of base excitation. On August 24th 2016 an earthquake hit Central Italy approximately 75 km (47 mi) southeast of the city of Perugia. 299 people were killed and the town of Amatrice was heavily damaged. A close look at the town center of Amatrice post-event, as shown in figure 3.21 shows that the town's bell tower is still standing when the shorter residential buildings have collapsed. A simplified explanation for the robustness of the bell tower can be found in the fact the tall and slender bell tower has a natural frequency lower than that of the excitation force of the earthquake. In comparison, the shorter and stiffer residential structures tend to have a higher natural frequency that more closely aligns with the excitation frequency of the earthquake, thereby resulting in these structures being excited closer to resonance.



Figure 3.21: The town center of Amatrice Italy after the August 24th 2016 earthquake that measured 6.2 on the moment magnitude scale; note that the bell tower (lower natural frequency) is still standing while shorter stiffer structures (higher natural frequency) have suffered extensive damage.^a

The architectural and cultural importance of bell towers leads to considerable efforts to protect and preserve these historic structures, in addition to ensuring their safety to protect the public post-event. During the August 24th earthquake, a team at the University of Perugia was actively monitoring the bell tower at Basilica di San Pietro in the city of Perugia with the intention of tracking the tower's dynamics through time to better understand the tower's state; thereby enabling better preservation of the tower. Figure 3.22(a) shows the bell tower, while figure 3.22(b) shows a sensor placed within the tower. Lastly, figure 3.22(c) shows Italian researcher Nicola Cavalagli inspecting the data recorded from the accelerometer on the bell tower on the morning of August 24th. A visual inspection of the monument the day after the event did not result in the identification of damage. However, by comparing the vibration signal from before and after the event, researchers were able to detect anomalies in the tower's structural behavior through statistical analysis of the vibration data.^b This statistical data is then matched with a finite element model of the system tower to infer likely locations of damage.

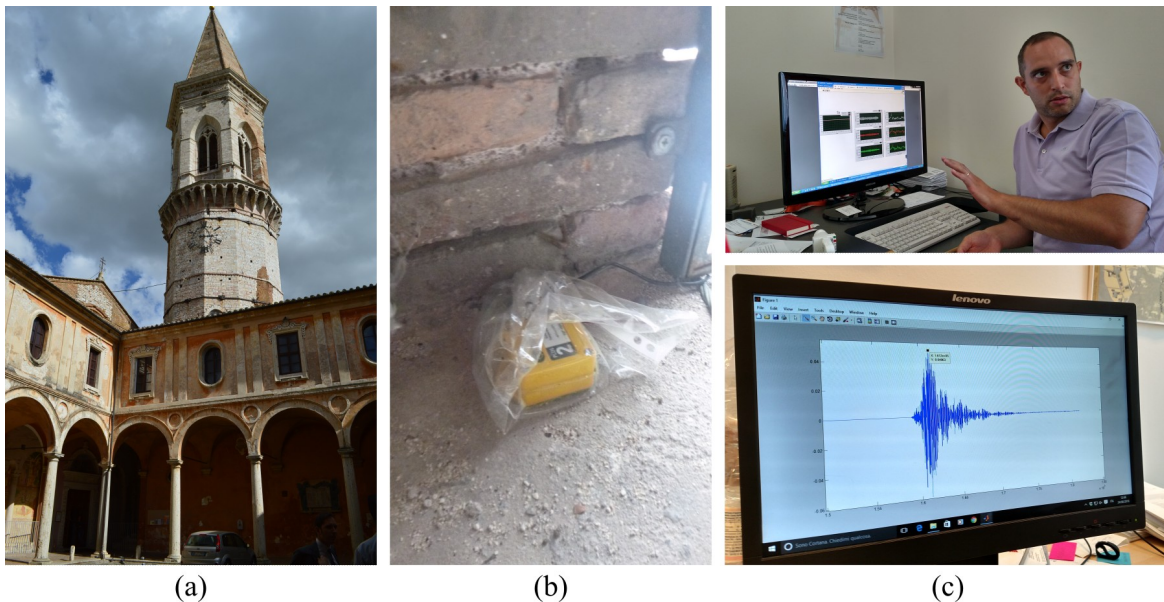

Figure 3.22: Bell tower at Basilica di San Pietro, showing: (a) the bell tower, (b) a sensor in the bell tower, and (c) data collected during the Central Italy earthquake of August 24, 2016.^c

^aImage cropped from original photo by Leggi il Firenzepost, CC BY 3.0 <<https://creativecommons.org/licenses/by/3.0/>>, via Wikimedia Commons

^bGiordano, P. F., Ubertini, F., Cavalagli, N., Kita, A., & Masciotta, M. G. (2020). Four years of structural health monitoring of the San Pietro bell tower in Perugia, Italy: two years before the earthquake versus two years after. *International Journal of Masonry Research and Innovation*, 5(4), 445-467.

^cAustin R.J. Downey, CC BY-SA 3.0 <<https://creativecommons.org/licenses/by/3.0/>>

3.5.1 Displacement Transmissibility Solution for Base Excitation

The steady-state solution is often more important than the transient solution when designing systems for continuous use. The particular solution for the base excited system annotated in figure 3.20 with the EOM presented in equation 3.108 can be expressed as $x_p(t)$. To solve for this expression we will use the linearity of the system and solve for a solution that is the sum of two particular solutions. Resulting in:

$$x_p(t) = x_p^{(1)}(t) + x_p^{(2)}(t) \quad (3.109)$$

Recall that the steady state solution for a harmonically excited spring-mass-damper can be expressed as $x_p(t) = X \cos(\omega t - \phi_p)$, as denoted in equation 3.55. For the base excitation problem, we will convert this expression to $x_p(t) = X \cos(\omega_b t - \phi_1)$. Therefore, for a base excited problem, the forcing function can be expressed as the sum of particular solutions:

$$C \cos(\omega_b t) + D \sin(\omega_b t) = x_p = x_p^{(1)} + x_p^{(2)} \quad (3.110)$$

where we dropped the (t) term from the expression for simplicity. We can then write:

$$x_p^{(1)} = X^{(1)} \cos(\omega_b t - \phi_1) \quad (3.111)$$

$$x_p^{(2)} = X^{(2)} \sin(\omega_b t - \phi_1) \quad (3.112)$$

NOTE

$x_p^{(1)}$ uses a cos term while $x_p^{(2)}$ uses a sin term. Both solutions use ϕ_1 as the damping term as the phase angle is independent of the excitation amplitude and the sin and cos terms account for the difference in phase.

For $x_p^{(1)}$, we again use the method of undetermined coefficients to obtain a solution for $x_p^{(1)} = X^{(1)} \cos(\omega_b t - \phi_1)$. This can be as simple as setting $2\zeta \omega_n \omega_b Y$ equal to f_0 from equation 3.71 that defines X for underdamped systems. Again, $2\zeta \omega_n \omega_b Y$ comes from the EOM in standard form as presented in equation 3.107. We can do this because both terms can be considered a “driving force”. This results in the equation:

$$x_p^{(1)} = \frac{2\zeta \omega_n \omega_b Y}{\sqrt{(\omega_n^2 - \omega_b^2)^2 + (2\zeta \omega_n \omega_b)^2}} \cos(\omega_b t - \phi_1) \quad (3.113)$$

where:

$$\phi_1 = \tan^{-1} \left(\frac{2\zeta \omega_n \omega_b}{\omega_n^2 - \omega_b^2} \right) \quad (3.114)$$

Next, the particular solution associated with $x_p^{(2)} = X^{(2)} \sin(\omega_b t - \phi_1)$ can be obtained using the same method of undetermined coefficients and setting f_0 from equation 3.71 to the driving force for $x_p^{(2)}$ in equation 3.107, ω_n^2 . This results in:

$$x_p^{(2)} = \frac{\omega_n^2 Y}{\sqrt{(\omega_n^2 - \omega_b^2)^2 + (2\zeta \omega_n \omega_b)^2}} \sin(\omega_b t - \phi_1) \quad (3.115)$$

As both equation 3.113 and 3.115 have the same argument ($\omega_b t - \phi_1$), these can be added as:

$$x_p = x_p^{(1)} + x_p^{(2)} \quad (3.116)$$

to obtain:

$$x_p = \omega_n Y \sqrt{\frac{\omega_n^2 + (2\zeta \omega_b)^2}{(\omega_n^2 - \omega_b^2)^2 + (2\zeta \omega_n \omega_b)^2}} \cos(\omega_b t - \phi_1 - \phi_2) \quad (3.117)$$

and:

$$\phi_2 = \tan^{-1} \left(\frac{\omega_n}{2\zeta \omega_b} \right) \quad (3.118)$$

where ϕ_2 is added to account for the cos and sin terms being combined. Again, the (t) has been dropped for simplicity.

As before, if we want to investigate how a frequency input will affect the response (frequency response) we can substitute substitute

$$r = \frac{\omega_b}{\omega_n} \quad (3.119)$$

into the temporal response to obtain:

$$X = Y \sqrt{\frac{1 + (2\zeta r)^2}{(1 - r^2)^2 + (2\zeta r)^2}} \quad (3.120)$$

Next, if we divide by Y we can obtain a normalized expression for the displacement:

$$\frac{X}{Y} = \sqrt{\frac{1 + (2\zeta r)^2}{(1 - r^2)^2 + (2\zeta r)^2}} \quad (3.121)$$

Plotting this for several critical damping ratios:

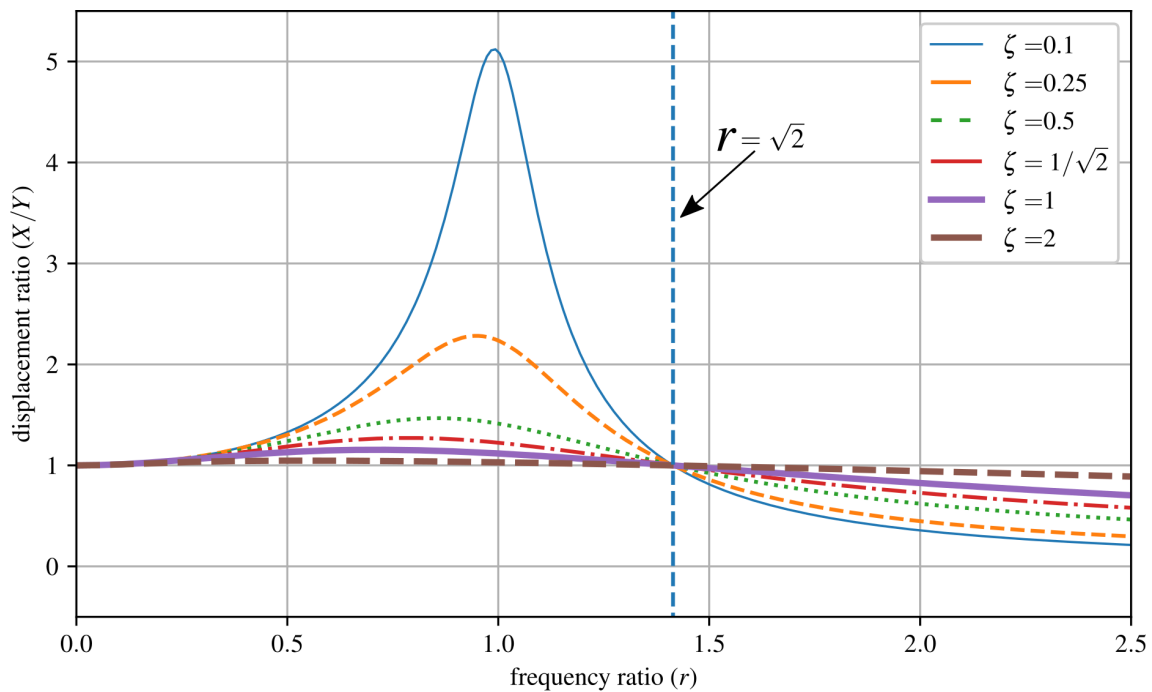

Figure 3.23: Displacement transmissibility for an underdamped 1-DOF system.

Around resonance, the maximum amount of displacement is transmitted to the mass. Additionally, the above plot shows that at $r = \sqrt{2}$ the displacement transmissibility X/Y is 1. Note the “flip” where overdamped systems have a greater response to excitations after $r = \sqrt{2}$ than do underdamped systems.

Example 3.7 Car Traveling over Rough Road

A very common example of base motion is the SDOF model of a vehicle wheel driving over a “rough” road as shown below. For this, let’s consider a generic modern sports sedan that we can diagram as below

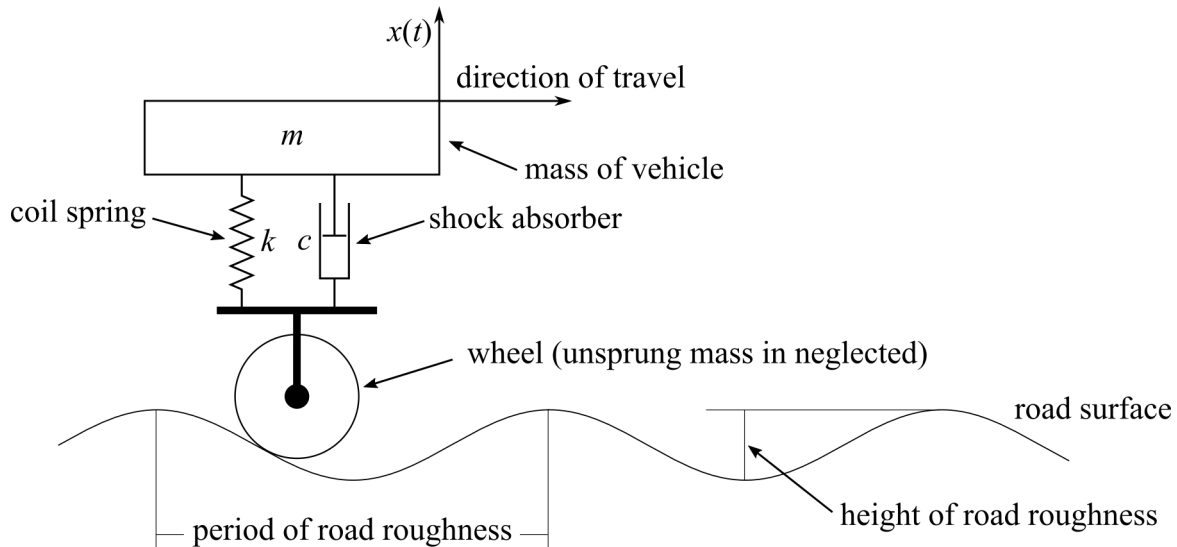

Figure 3.24: A 1-DOF “car” traveling over an uneven road.

where $k = 300,000$ N/m, $m = 1600$ kg, $c = 15,000$ kg/s, the period of road roughness = 3 m, and the height of road roughness = 0.01 m. What is the deflection experience by the car at $v = 50$ km/h?

Solution:

The road is applying a base excitation that can be approximated as

$$Y = 0.005 \text{ m} \quad (3.122)$$

$$v \text{ m/s} = 50 \text{ km/hr} \left(\frac{1000 \text{ m}}{1 \text{ km}} \right) \left(\frac{1 \text{ hours}}{3600 \text{ s}} \right) = 13.888 \text{ m/sec} \quad (3.123)$$

$$\omega_b = \left(\frac{13.88 \text{ m}}{\text{s}} \right) \left(\frac{1 \text{ cycle}}{3 \text{ m}} \right) \left(\frac{2\pi \text{ rad}}{\text{cycle}} \right) = \text{rad/s} = 29.08 \text{ rad/s} \quad (3.124)$$

Therefore, the sinusoidal for the base excitation is then:

$$y(t) = (0.005)\sin(29.08t) \quad (3.125)$$

Next, we can calculate the natural frequency:

$$\omega_n = \sqrt{\frac{k}{m}} = \sqrt{\frac{300,000}{1600}} = 13.69 \text{ rad/s} \quad (3.126)$$

Therefore:

$$r = \frac{\omega_b}{\omega_n} = 2.124 \quad (3.127)$$

and:

$$\zeta = \frac{c}{2\sqrt{km}} = \frac{15,000}{2\sqrt{1600 \cdot 300,000}} = 0.342 \quad (3.128)$$

Then it can be found that the maximum deflection of the car is:

$$X = Y \sqrt{\frac{1 + (2\zeta r)^2}{(1 - r^2)^2 + (2\zeta r)^2}} = Y \sqrt{\frac{1 + (2 \cdot 0.3423 \cdot 2.124)^2}{(1 - 2.124^2)^2 + (2 \cdot 0.3423 \cdot 2.124)^2}} \quad (3.129)$$

$$= 0.0023 \text{ m}$$

3.5.2 Force Transmissibility Solution for Base Excitation

For some systems, such as those with weak connections, the force transmitted to the mass is more important than the displacement of the mass. The force transmitted to the mass is the sum of the forces applied by the spring and damper. From the FBD shown in figure 3.20,

$$F(t) = k(x - y) + c(\dot{x} - \dot{y}) \quad (3.130)$$

where this force is counteracted by the inertial force of the mass:

$$F(t) = -m\ddot{x}(t) \quad (3.131)$$

Only considering the steady state we found that

$$x_p(t) = \omega_n Y \sqrt{\frac{\omega_n^2 + (2\zeta \omega_b)^2}{(\omega_n^2 - \omega_b^2)^2 + (2\zeta \omega_n \omega_b)^2}} \cos(\omega_b t - \phi_1 - \phi_2) \quad (3.132)$$

if we differentiate this twice, to obtain $\ddot{x}(t)$ and combine this with $F(t) = -m\ddot{x}(t)$ we get:

$$F(t) = m\omega_b^2 \omega_n Y \sqrt{\frac{\omega_n^2 + (2\zeta \omega_b)^2}{(\omega_n^2 - \omega_b^2)^2 + (2\zeta \omega_n \omega_b)^2}} \cos(\omega_b t - \phi_1 - \phi_2) \quad (3.133)$$

where the negative sign $F(t) = -m\ddot{x}(t)$ as the force transmitted to the mass is both positive and negative and we are solving for the amplitude of the transmitted force. Again applying:

$$r = \frac{\omega_b}{\omega_n} \quad (3.134)$$

this becomes:

$$F(t) = F_T \cos(\omega_b t - \phi_1 - \phi_2) \quad (3.135)$$

where F_T is the magnitude of the transmitted force and is

$$F_T = kYr^2 \sqrt{\frac{1 + (2\zeta r)^2}{(1 - r^2)^2 + (2\zeta r)^2}} \quad (3.136)$$

Again, this can be converted to force transmissibility to provide a normalized response such that:

$$\frac{F_T}{kY} = r^2 \sqrt{\frac{1 + (2\zeta r)^2}{(1 - r^2)^2 + (2\zeta r)^2}} \quad (3.137)$$

Plotting this for several critical damping ratios:

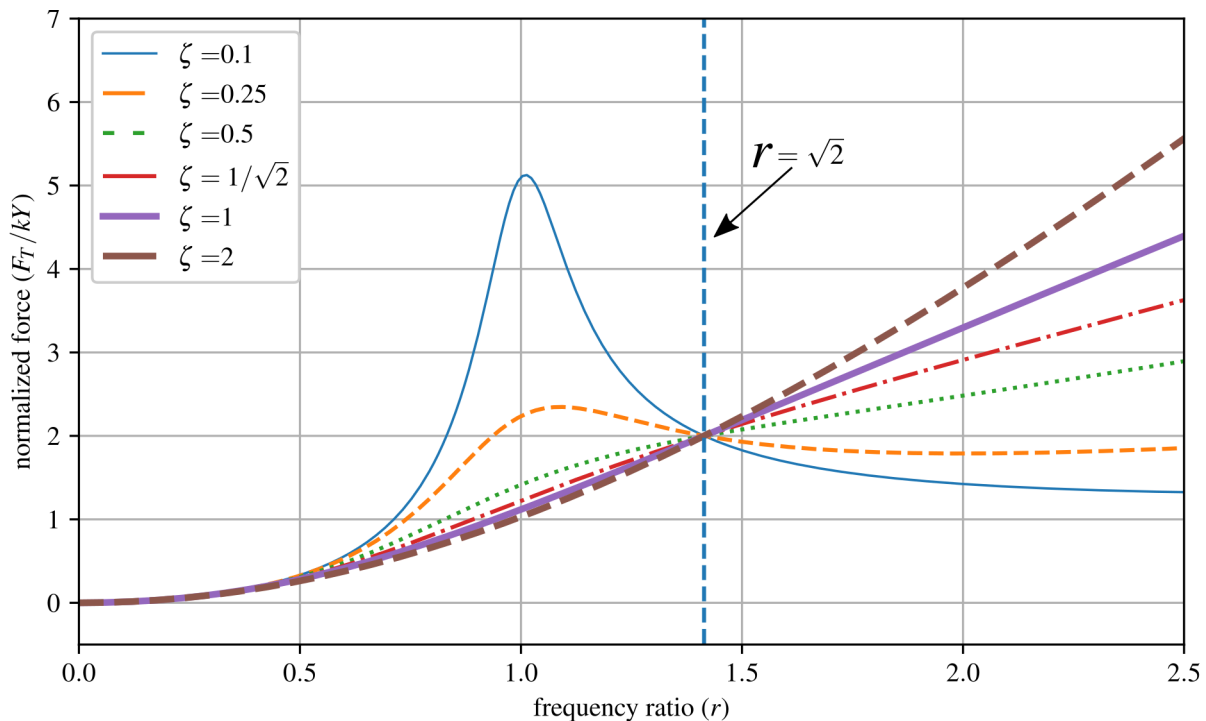

Figure 3.25: Force transmissibility for an underdamped 1-DOF system.

Again, note the key location $r = \sqrt{2}$. At $r = \sqrt{2}$ the force transmitted to the system is $2 \frac{F_T}{kY}$. However, the normalized force does not necessarily fall off for r values greater than $r = \sqrt{2}$.

Vibration Case Study 3.4 Convair F2Y Sea Dart

The Convair F2Y Sea Dart was a prototype seaplane fighter developed by the United States Navy in the early 1950s to enable sea-based jet fighters. One key technical issue with the aircraft's development was the violent forces induced into the plane when the hydro-skis contacted the uneven surfaces of the water. Furthermore, adding damping to the skies proved to be changed as the damping required changed significantly as a function of the hydro-skis contact with the water. Significant work went into the skies and shock-absorbing struts, which helped to improve the situation but it was never fully repaired.



Figure 3.26: The Convair F2Y Sea Dart, showing: a) XF2Y-1 Sea Dart (BuNo 135762) during landing. This airframe disintegrated in mid-air over San Diego Bay, California (USA) during a demonstration flight on November 4th, 1954 killing test pilot Charles E. Richbourg after the airframe limitations were exceeded^a, and b) the hydro-skis undergoing extensive testing on a pantograph mounted on a speed boat to study the forces transmitted to the airframe from the hydro-skis^b.

^aPublic Domain U.S. Navy National Museum of Naval Aviation photo No. 1996.253.7213.010

^bImage from “The Impossible Takes Longer”, a film by Convair about Sea Dart development. The copyright of the image is unknown but may be held by the successor entities of Convair. It is believed that the use of this image qualifies as fair use under the copyright law of the United States.

Example 3.8 System Design for Force Transmissibility

For the system given below and excited at the base, should the system be excited above or below the natural frequency if the transmitted force is the design limitation? Consider the under-damped case with $\zeta = 0.1$, and the over-damped case with $\zeta = 2$ conditions.

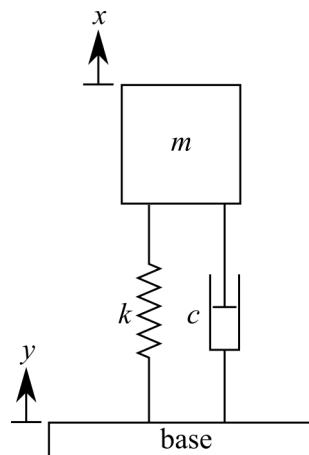

Figure 3.27: Force transmissibility for an underdamped 1-DOF system.

Solution:

We can plot the transmissibility of both the force and displacement onto one plot. For $\zeta = 0.1$

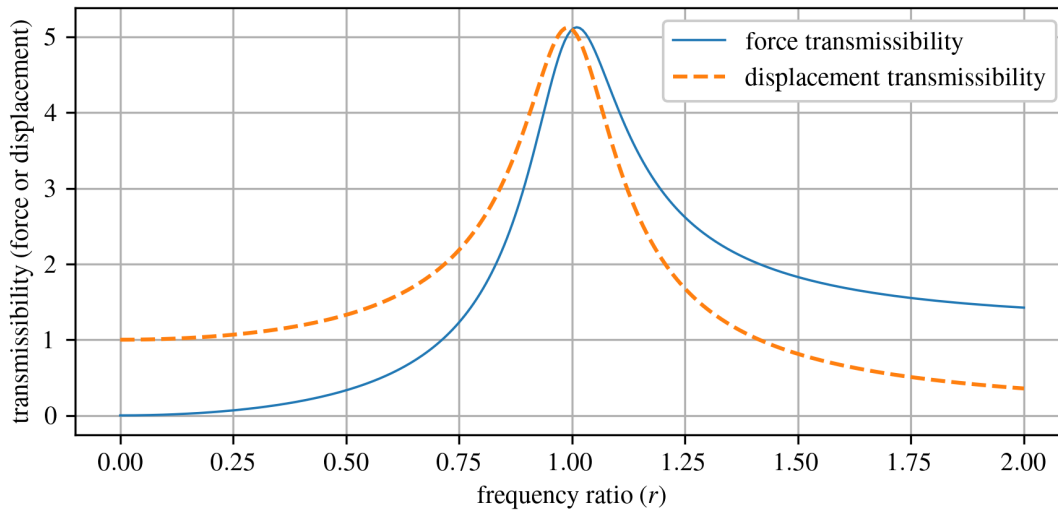

Figure 3.28: Force and displacement transmissibility for the considered base excited system with $\zeta = 0.1$.

it is clear that to minimize the force, the system should be driven with a frequency below the natural frequency. Next for $\zeta = 2$:

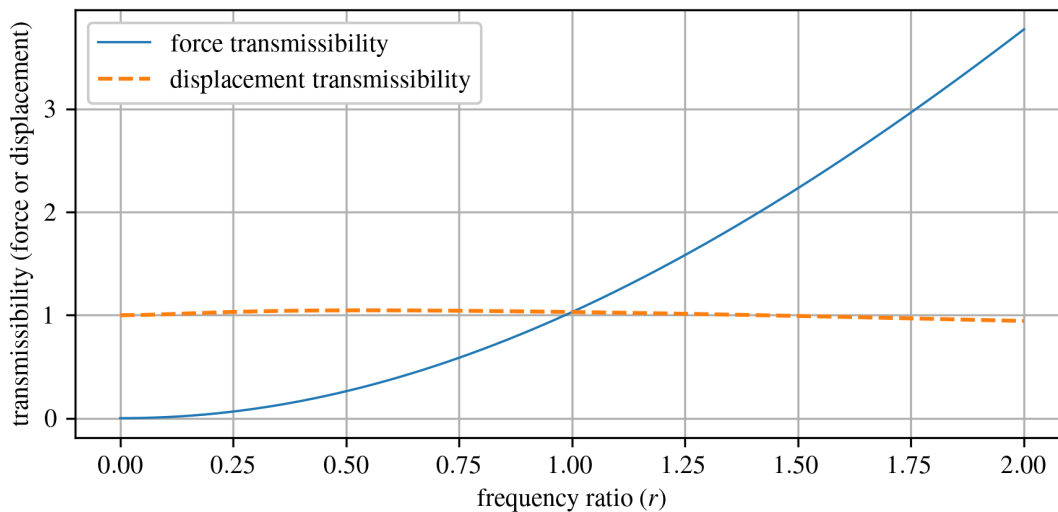

Figure 3.29: Force and displacement transmissibility for the considered base excited system with $\zeta = 2$.

it can be seen that the same rationale applies. Therefore, for both $\zeta = 0.1$ and $\zeta = 2$ the system should be excited below the natural frequency.

Example 3.9 Damping in a Single-story Building

A single-story building is subjected to a harmonic ground motion, $\ddot{y}(t) = A\cos(\omega_b t)$. a) Find the steady-state solution for the structure. b) If a damper was added between the base and the floor, and $r = 2$, what would be the ideal critical damping coefficient to ensure the safety of the building? (Think of safety as limiting displacement and transmitted force.)

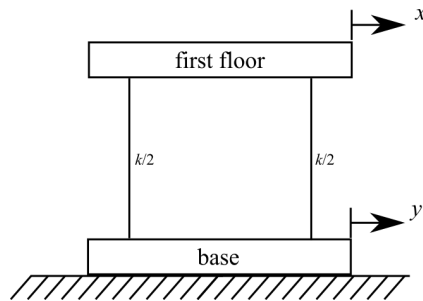

Figure 3.30: A 1-DOF laterally excited system that represents a 1-story building.

Solution (a):

For simplicity, we can rearrange the system as what follows:

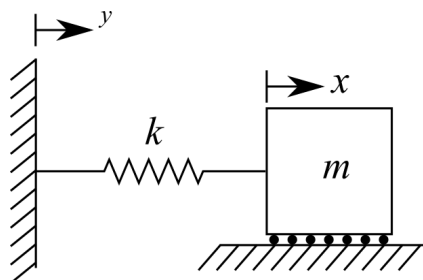

Figure 3.31: A base excited 1-DOF spring-mass system.

solving for the EOM yields:

$$m\ddot{x} + kx = ky \tag{3.138}$$

Notice that this is the same as the EOM for a damped 1-DOF system if $c = 0$.

$$m\ddot{x} + c\dot{x} + kx = +c\dot{y} + ky \rightarrow m\ddot{x} + kx = ky \tag{3.139}$$

Therefore, we can use the solution:

$$x_p(t) = \omega_n Y \sqrt{\frac{\omega_n^2 + (2\zeta\omega_b)^2}{(\omega_n^2 - \omega_b^2)^2 + (2\zeta\omega_n\omega_b)^2}} \cos(\omega_b t - \phi_1 - \phi_2) \tag{3.140}$$

where:

$$\phi_1 = \tan^{-1} \left(\frac{2\zeta\omega_n\omega_b}{\omega_n^2 - \omega_b^2} \right) \tag{3.141}$$

$$\phi_2 = \tan^{-1} \left(\frac{\omega_n}{2\zeta\omega_b} \right) \quad (3.142)$$

Now we have, or can easily get, values for ω_n , ω_b , and ζ . However, we do not have an expression for Y . We can extract the displacement (and therefore the Y) from the acceleration as:

$$\ddot{y}(t) = A \cos(\omega t) \quad (3.143)$$

$$\dot{y}(t) = \frac{A}{\omega} \sin(\omega t) + C_1 \quad (3.144)$$

$$y(t) = -\frac{A}{\omega^2} \cos(\omega t) + C_1 t + C_2 \quad (3.145)$$

Resulting in

$$Y = -\frac{A}{\omega^2} \quad (3.146)$$

Solution (b):

From the plots we solved for before, we can see that we want a critical damping coefficient that is as low as possible. This means any damping added to the system will decrease its safety. This may seem counter-intuitive, but this is because we are attempting to drive the structure at a frequency higher than its natural frequency, something that does not commonly happen. Typically excitations for a structure are well below its natural frequency.

3.6 Numerical Methods

Numerical methods can be used to solve the response of a system subjected to forced vibrations. While not the most computationally efficient method, the EOM is an ODE that can be solved directly while considering the initial directions to obtain the response of the system.

Example 3.10 Directly Solving the Ordinary Differential Equation

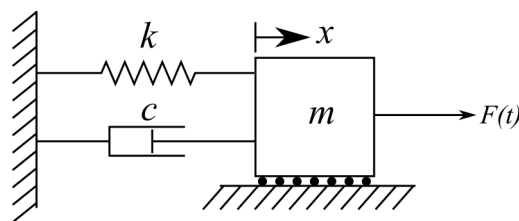

Figure 3.32: Damped 1-DOF spring-mass system subjected to an external force $F(t)$.

Using the EOM for the system in figure 3.32 solve for its temporal response by directly solving the ODE for a system initially at rest with $m = 1$ kg, $c = 0.2$, $k = 2.0$, and $F(t) = 1/2 \sin(2\pi t)$.

Solution:

In MATLAB, ode45 is a versatile ODE solver and is one of the first solvers you should try for most problems. The solver is setup as $[t, y] = \text{ode45}(\text{odefun}, \text{tspan}, y_0)$, where $\text{tspan} = [t_0 \ t_f]$, integrates the system of differential equations $y' = f(t, y)$ from t_0 to t_f with

initial conditions y_0 . Each row in the solution array y corresponds to a value returned in column vector t . The ODE is re-organized as

$$\ddot{x} = (f_t - c\dot{x} - kx)/m \quad (3.147)$$

for the `ode45` solver. Listing 4 reports the code needed to solve the time response of the system shown in figure 3.32.

Listing 1: MATLAB code for solving the EOM through time.

```
% Time span for simulation
tspan = [0, 10]; % Start time and end time

% Initial conditions [x, x']
initial_conditions = [0, 0];

% Use ode45 to solve the system of ODEs
[t, y] = ode45(@equation_of_motion, tspan, initial_conditions);

% Extract displacement and velocity
x = y(:, 1);
x_dot = y(:, 2);
```

The code in listing 4 needs to be combined with the functions in listing 5 and plotting code to obtain the results shown in figure 3.33.

Listing 2: Functions called from the main code in listing 4.

```
% Equation of motion for the system
function dydt = equation_of_motion(t, y)
    % Mass, damping coefficient, and spring constant
    m = 1.0; % Mass
    c = 0.2; % Damping coefficient
    k = 2.0; % Spring constant

    % Unpack the state variables
    x = y(1);
    x_dot = y(2);

    % Define the force excitation function f(t)
    f_t = force_excitation_function(t);

    % Equation of motion
    x_dotdot = (f_t - c * x_dot - k * x) / m;

    % Pack the derivatives into the output vector dydt
    dydt = [x_dot; x_dotdot];
end

% Force excitation function f(t) for a sinusoidal force excitation
function f_t = force_excitation_function(t)
    f_t = 0.5 * sin(2 * pi * t);
end
```

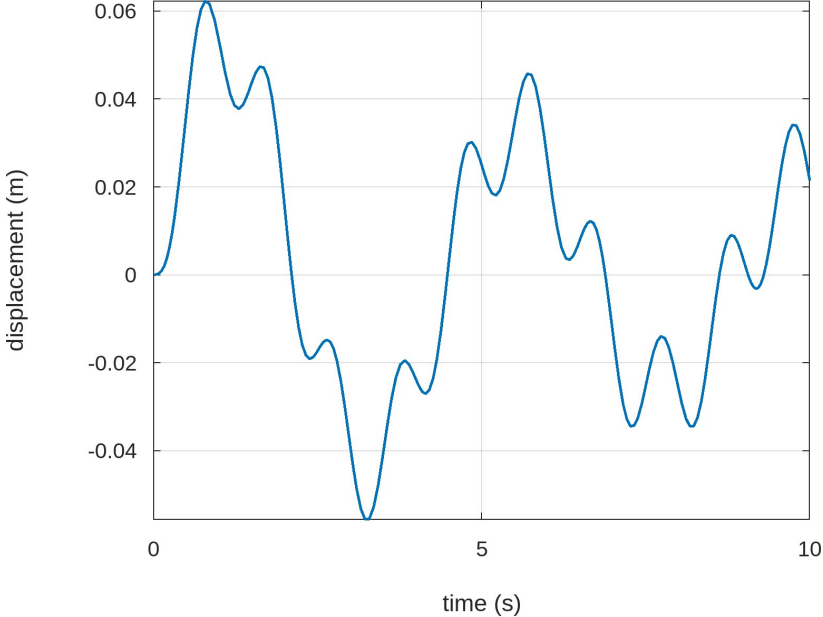

Figure 3.33: Displacement response of the 1-DOF system in in figure 3.32.

4 Transfer Function Approach

Thus far, this text has only considered forced vibrations for 1-DOF systems excited with forcing functions that can be easily expressed using either sin or cos examples. Therefore, the previously developed solutions are only acceptable for systems with known and simple excitations. This chapter will introduce the concept of transfer functions for solving vibration-related problems. The transfer function, in particular the Laplace transfer function, is an important tool in the study of vibrations as it allows the practitioner to solve for the temporal response of a system for a variety of inputs using a single approach. Examples of force excitation that can be calculated include using this method include:

- sinusoidal
- base excitation
- impulse
- arbitrary input

4.1 Transfer Function Method (Generic)

Consider the following system

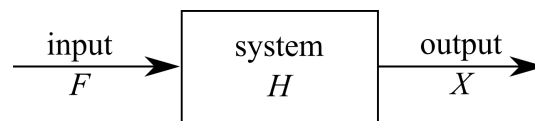

Figure 4.1: Generic system H subjected to an input F and its corresponding output X .

where F is the input, H is the system, and X is the output from the system. This formulation is called the transfer-function approach and is commonly used for the formulation and solution of dynamic problems in the control literature. It can also be used for solving various forced-vibration problems including those from complex or stochastic inputs.

Review 4.1 Laplace Transform

Laplace transforms, or more broadly integral transforms, are a procedure for integrating the time (t) dependence of a function into a function of position or space (s). By transforming the whole differential equation from the time domain into a lower-order function of space the problem becomes easier to solve as the function can often be manipulated algebraically. The Laplace transform ($\mathcal{L}[\]$) of the function $f(t)$, expressed as $\mathcal{L}[f(t)]$. Here, a Laplace transform is used as a method of solving the differential equations of motion by reducing the computation needed to that of integration and algebraic manipulation.

The definition of the Laplace transform of the function $f(t)$ is:

$$\mathcal{L}[f(t)] = F(s) = \int_0^{\infty} f(t)e^{-st} dt \quad (4.1)$$

where s represents a variable in the complex plane (also called the s -plane) and $f(t) = 0$ for all values of $t < 0$. Here, the s is a complex value. Lastly, the term $F(s)$ is a generic term

that represents the input to a system. As this class needs the derivatives of the base function, we will calculate these next:

$$\mathcal{L}[\dot{f}(t)] = \int_0^{\infty} \dot{f}(t)e^{-st} dt = \int_0^{\infty} e^{-st} \frac{d[f(t)]}{dt} dt \quad (4.2)$$

integration by parts yields:

$$\mathcal{L}[\dot{f}(t)] = e^{-st} f(t) \Big|_0^{\infty} + s \int_0^{\infty} e^{-st} f(t) dt \quad (4.3)$$

Astutely, it can be noticed that the second term $s \int_0^{\infty} e^{-st} f(t) dt$ is the input to the system $F(s)$. With a little rearranging, this becomes:

$$\mathcal{L}[\dot{f}(t)] = sF(s) - f(0) \quad (4.4)$$

Taking the derivative of again yields:

$$\mathcal{L}[\ddot{f}(t)] = s^2 F(s) - sf(0) - \dot{f}(0) \quad (4.5)$$

A few key points of the Laplace transforms are:

- The domain of the problem changes from the real number line (t) to the complex plane (s -plane).
- The integration of the Laplace transform changes differentiation into multiplication.
- The transform procedure is linear. Therefore, the transform of the linear combination of two transforms is the same as the linear transformation of these functions.
- To move from the time domain to the complex number plane we typically use tables of pre-solved integral.
- The function $x(t)$ can be obtained by taking the inverse Laplace transform defined as $x(t) = \mathcal{L}[X(s)]^{-1}$

The Laplace transform can be calculated in symbolic form. In particular interest to this text is the Laplace form of the system input $F(s)$ and output $X(s)$. To expand the symbolic form of the Laplace transform for the system inputs are and for system outputs:

$$\mathcal{L}[f(t)] = F(s) \quad (4.6)$$

$$\mathcal{L}[\dot{f}(t)] = sF(s) - f(0) \quad (4.7)$$

$$\mathcal{L}[\ddot{f}(t)] = s^2 F(s) - sf(0) - \dot{f}(0) \quad (4.8)$$

here, $f(0)$ and $\dot{f}(0)$ are the initial values of the function $f(t)$. Furthermore, the system outputs are:

$$\mathcal{L}[x(t)] = X(s) \quad (4.9)$$

$$\mathcal{L}[\dot{x}(t)] = sX(s) - x(0) \quad (4.10)$$

$$\mathcal{L}[\ddot{x}(t)] = s^2X(s) - sx(0) - \dot{x}(0) \quad (4.11)$$

here, $x(0)$ and $\dot{x}(0)$ are the initial values of the function $x(t)$.

4.2 Transfer Function Method for Solving Vibrating Systems

As mentioned in the introduction to this chapter, a variety of systems can be solved for using the transfer function method. The procedure for using the Laplace transform to solve equations of motion expressed as an inhomogeneous ordinary differential equation is:

1. Take the Laplace transform of both sides of the EOM while treating the time derivatives symbolically.
2. Solve for $X(s)$ in the obtained equation.
3. Apply the inverse transform $x(t) = \mathcal{L}[X(s)]^{-1}$

4.2.1 Free Vibration for Undamped Systems

Consider the undamped single-DOF system:

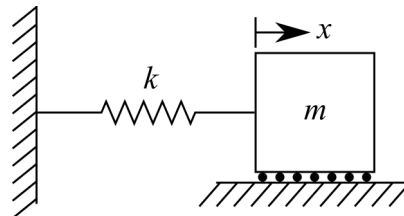

Figure 4.2: A spring-mass model of a 1-DOF system.

The EOM for this system is a homogeneous differential equation because the right-hand side is equal to zero:

$$m\ddot{x}(t) + kx(t) = 0 \quad (4.12)$$

Here we will leave the “(t)” for clarity to differentiate the time domain solution from Laplace solution “(s)” in the s -plane, as discussed in review 4.1. The EOM can be rewritten in standard form as:

$$\ddot{x}(t) + \omega_n^2 x(t) = 0 \quad (4.13)$$

where the initial conditions at $t = 0$ are $x(0) = x_0$ and $\dot{x}(0) = v_0$. Taking the Laplace transforms, in symbolic form using equations 4.9 - 4.11, of both sides of the EOM yields:

$$[s^2X(s) - sx_0 - v_0] + [\omega_n^2X(s)] = 0 \quad (4.14)$$

using equations 4.9 and 4.11 from section 4.1. Solving for the output of the system $X(s)$ yields:

$$X(s) = \frac{sx_0 + v_0}{s^2 + \omega_n^2} \quad (4.15)$$

We can expand this form of $X(s)$ to obtain equations listed in our Laplace Transform table:

$$X(s) = \frac{sx_0}{s^2 + \omega_n^2} + \frac{v_0}{s^2 + \omega_n^2} \cdot \frac{\omega_n}{\omega_n} \quad (4.16)$$

This becomes:

$$X(s) = x_0 \frac{s}{s^2 + \omega_n^2} + \left(\frac{v_0}{\omega_n} \right) \cdot \frac{\omega_n}{s^2 + \omega_n^2} \quad (4.17)$$

Next, using the inverse Laplace transform $x(t) = \mathcal{L}[X(s)]^{-1}$ and the two following Laplace transforms (#5 and #6):

$$f(t) \text{ is } \cos(\omega t) \text{ when } F(s) \text{ is } \frac{s}{s^2 + \omega^2} \quad (4.18)$$

$$f(t) \text{ is } \sin(\omega t) \text{ when } F(s) \text{ is } \frac{\omega}{s^2 + \omega^2} \quad (4.19)$$

Therefore, we can obtain the solution for the system output $X(s)$ as:

$$x(t) = x_0 \cos(\omega_n t) + \frac{v_0}{\omega_n} \sin(\omega_n t) \quad (4.20)$$

The same procedure can be used to calculate the under-damped and forced responses. However, when calculating these responses the algebraic solution for $X(s)$, s often contains quotients of polynomials. These Polynomial ratios may not be found in simple Laplace tables and must be solved using the method of partial fractions. An example of this procedure can be found in Appendix B of Inman^a.

Review 4.2 Pierre-Simon Laplace

The Laplace transform is named after mathematician and astronomer Pierre-Simon Laplace (23 March 1749 - 5 March 1827). Pierre-Simon Laplace was one of the greatest scientists of all time and is often considered the French Newton. He taught Napoleon at the École Militaire in 1784, became a count of the empire in 1806, and a marquis in 1817 after the restoration of the monarchy. He is credited with advancements in engineering, mathematics, statistics, physics, astronomy, and philosophy; however, maybe his greatest achievement is not only surviving but benefiting from the change from the Ancien Régime → Bonaparte → Bourbon Restoration.

^aInman, Daniel J., and Ramesh Chandra Singh. "Engineering vibrations". Vol. 3. Englewood Cliffs, NJ: Prentice Hall, 1994.



Figure 4.3: Portrait of Pierre-Simon Laplace by Johann Ernst Heinsius (1775).^a

^aJohann Ernst Heinsius, CC BY-SA 4.0 <<https://creativecommons.org/licenses/by-sa/4.0/>>, via Wikimedia Commons

4.2.2 Impulse Response Function

Shock loads on mechanical systems represent a very common source of vibration. These short-duration forces are also called an impulse. An impulse excitation is defined as a force that is applied for a very short, or infinitesimal, length of time. An impulse is a nonperiodic force that is represented by the lower case delta symbol (δ). The response of a system to an impulse load is the same as the system's free response provided that the correct initial conditions are applied. This is illustrated in the following where the applied force $F(t)$ is impulsive (i.e., large magnitude over a very short time).

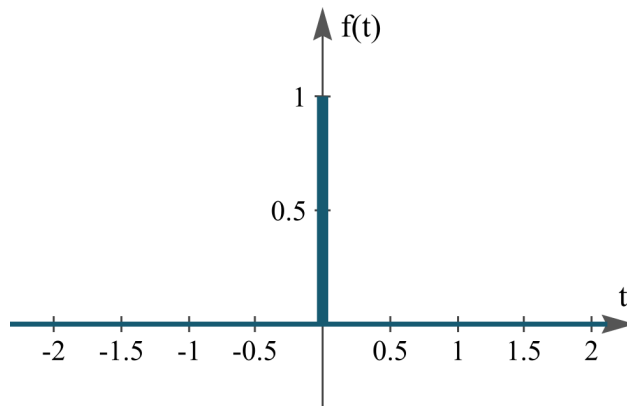

Figure 4.4: An impulse function with the impulse at $t = 0$.

The impulse response function can be solved for analytically, however, we will solve it using the transfer function approach. Here we will consider the under-damped spring-mass system. First, assume that the system is at rest (no initial conditions). Next, we write the EOM as:

$$m\ddot{x} + c\dot{x} + kx = \delta(t) \quad (4.21)$$

Taking the Laplace transform of both sides of the equation yields

$$m(s^2X(s) - sx(0) - \dot{x}(0)) + c(sX(s) - x(0)) + kX(s) = 1 \quad (4.22)$$

The $\mathcal{L}[\delta] = 1$ per #1 in the transform table. However, if we assume zero initial conditions (a system at rest when the impulse happens), the equation simplifies too.

$$ms^2X(s) + csX(s) + kX(s) = 1 \quad (4.23)$$

or

$$(ms^2 + cs + k)X(s) = 1 \quad (4.24)$$

Solving this equation for $X(s)$:

$$X(s) = \frac{1}{m} \cdot \frac{1}{s^2 + 2\zeta\omega_n s + \omega_n^2} \quad (4.25)$$

Again, the mass is extracted to develop a formulation that can be found in the Laplace tables. Setting the constraint that $\zeta < 1$ and consulting #10 in the table for Laplace transforms results in:

$$x(t) = \frac{1}{m\omega_d} e^{-\zeta\omega_n t} \sin(\omega_d t) \quad (4.26)$$

where this is the general solution for a damped system subjected to an impulse loading function. For the undamped case, a solution can be obtained by setting $\zeta = 0$. This results in the following form for the undamped case:

$$x(t) = \frac{1}{m\omega_n} \sin(\omega_n t) \quad (4.27)$$

Below is a typical response for both an undamped and underdamped 1-DOF system subject to an impulse response at $t = 0$ seconds.

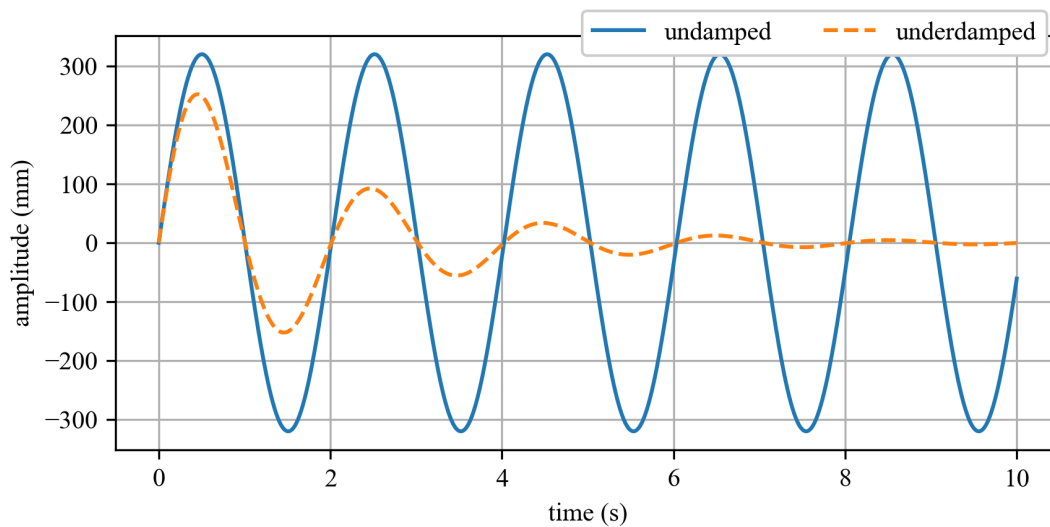

Figure 4.5: Temporal responses from underdamped and undamped 1-DOF systems to an impulse response function.

4.2.3 Unit Step function

Now consider a unit step function, denoted with a capital Greek Phi Φ :

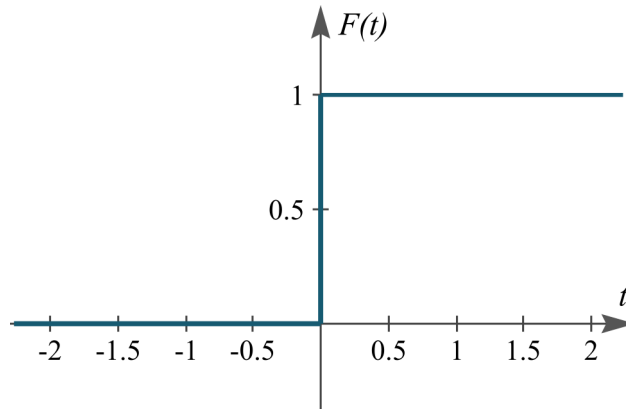

Figure 4.6: A Step function.

A step function is a common loading situation and can represent the dropping of a load into a truck, a car going over a curve, or a motor starting up.

The Laplace transform of the function, for a unit step function Φ , is:

$$\mathcal{L}[\Phi(t)] = \int_0^{\infty} e^{-st} dt = -\frac{e^{-\infty}}{s} + \frac{e^{-0}}{s} = \frac{1}{s}$$

This also lines up with Laplace Transform #3 from the Laplace table. This would be expected as Φ is used to represent the unit step function (i.e. a step function with a displacement of 1). As we consider linear systems in this class, we can scale the magnitude of the response by the magnitude of the impulse after the transform is performed.

4.2.4 Undamped Spring-mass System

For a spring-mass system subjected to a unit step, assuming both initial conditions are zero, the solution can be obtained using the transform method. First, the EOM is

$$m\ddot{x}(t) + kx(t) = \Phi(t) \quad (4.28)$$

Taking the Laplace transform of both sides and assuming zero initial conditions yields:

$$ms^2X(s) + kX(s) = \frac{1}{s} \quad (4.29)$$

Next, this equation is solved for $X(s)$ as:

$$X(s) = \frac{1}{s(ms^2 + k)} \quad (4.30)$$

This can be rearranged as:

$$X(s) = \frac{1}{m} \cdot \frac{1}{s(s^2 + \omega_n^2)} \quad (4.31)$$

where $\frac{1}{m}$ will pass through the Laplace function. Therefore, taking the inverse Laplace transform using #9 of the provided Laplace transforms yields:

$$x(t) = \frac{1}{m} \cdot \frac{1}{\omega_n^2} (1 - \cos(\omega_n t)) = \frac{1}{k} (1 - \cos(\omega_n t)) \quad (4.32)$$

4.2.5 Under Damped Spring-mass System

For a spring-mass-damper system subjected to a unit step, assuming both initial conditions are zero, the solution can be obtained using the transform method. First, the EOM is:

$$m\ddot{x}(t) + c\dot{x}(t) + kx(t) = \Phi(t) \quad (4.33)$$

Converting to the standard form results in:

$$\ddot{x}(t) + 2\zeta\omega_n\dot{x}(t) + \omega_n^2x(t) = \frac{1}{m} \cdot \Phi(t) \quad (4.34)$$

taking the Laplace transform of both sides and assuming zero initial conditions yields:

$$s^2X(s) + 2\zeta\omega_n sX(s) + \omega_n^2X(s) = \frac{1}{m} \cdot \frac{1}{s} \quad (4.35)$$

Next, this equation is solved for $X(s)$ as:

$$X(s) = \frac{1}{s^2 + 2\zeta\omega_n s + \omega_n^2} \cdot \frac{1}{m} \cdot \frac{1}{s} \quad (4.36)$$

multiplying the right-hand-side of this equation by $\frac{\omega_n^2}{\omega_n^2}$ results in:

$$X(s) = \frac{1}{m\omega_n^2} \cdot \frac{\omega_n^2}{s(s^2 + 2\zeta\omega_n s + \omega_n^2)} \quad (4.37)$$

Again, the $\frac{1}{m\omega_n^2}$ will pass through the Laplace function. Therefore, taking the inverse Laplace transform using #11 on the Laplace transform sheet yields:

$$x(t) = \frac{1}{m\omega_n^2} \cdot \left(1 - \frac{\omega_n}{\omega_d} e^{-\zeta\omega_n t} \sin(\omega_d t + \phi) \right), \text{ where } \phi = \cos^{-1}(\zeta), \text{ where } \zeta < 1 \quad (4.38)$$

After obtaining equations for the undamped and under-damped cases, the responses for the unit step, solved with the transform method, can be plotted as:

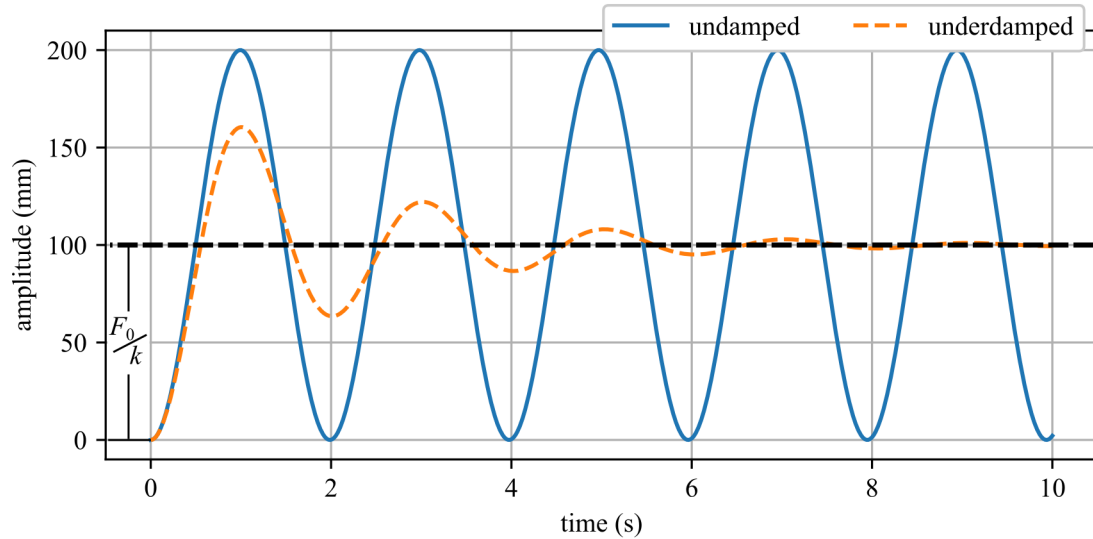

Figure 4.7: Temporal responses from underdamped and undamped 1-DOF systems subjected to an impulse response function.

Note that the system will settle out around F_0/k where $F_0\Phi$ is a scaling factor for the step loading.

Example 4.1 Displacement under Dynamic Loading

A load of dirt m is dumped into the back of a dump truck. The bed of the truck can be modeled as a spring-mass system where the load of dirt is modeled as a force $F(t) = mg$ that is applied to the system, as illustrated in figure 4.8. How does the maximum displacement of the truck bed compare to the steady-state displacement of the truck bed with the dirt in it?



(a)

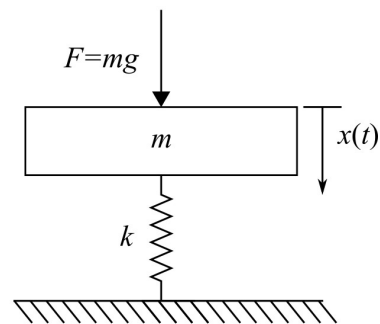

(b)

Figure 4.8: Dump truck being loaded with dirt showing (a) dirt going into the truck bed^a; and (b) the single-degree-of-freedom vibration model.

Solution:

Setting the load applied to the truck as 1 unit, it can be seen that this is a unit step loading condition with an undamped system. We can obtain a for the transient and steady-state

displacement of the truck bed knowing that the undamped displacement is

$$x(t) = \frac{1}{k}(1 - \cos(\omega_n t)) = \frac{mg}{k}(1 - \cos(\omega_n t)) \quad (4.39)$$

This equation has a maximum amplitude when the $\cos(\omega_n t) = -1$, resulting in:

$$x(t) = \frac{mg}{k}(1 - (-1)) \quad (4.40)$$

This can be rearranged for the maximum displacement value x_{\max} as:

$$x_{\max} = 2\frac{mg}{k} \quad (4.41)$$

Note that the transient displacement of the truck bed is twice that of the steady-state displacement. Therefore, if the truck manufacturer designed the truck to only take the static load of dirt (i.e. if the dirt were placed gently into the truck bed), the frame of the truck would be damaged when the dirt is dropped into the back of the truck. From this, it can be understood that it is important to consider the transient responses of a system during the design phase.

^aSGT Marvin Lynchard, A dump truck is filled with dirt, by members of the 459th Civil Engineering Flight, for use in repairing a damaged runway during Exercise Prime Beef '82, Public Domain, via picryl.com

Vibration Case Study 4.1 Limiting Wind-induced Loading

A smokestack or chimney stack is used to exhaust combustion gases into the outside air. The design of large stacks poses considerable challenges from a structural dynamics perspective. As high winds pass over the tower creating a combination of oscillating wind currents and complex vortex shedding that load the tower with a variety of wind-induced frequencies. This are called vortex-induced vibrations^a. This wide bandwidth of excitation results in a stack that is loaded near its resonant frequency. To mitigate this, stack designers have designed stacks with changing diameters to ensure that different parts of the stack have different resonant frequencies. Also, wind bands in the forms of protruding bricks or helical strakes are added to the stacks to prevent vortex shedding which reduces the loading on the tower.

Sadly, engineers understanding of vortex shedding and structural dynamics lagged behind the development of these structures; leading to multiple wind-induced collapses of smokestacks during the industrial revolution. The use of the transfer function approach gives the practitioner the ability to easily model the complex response of smokestack excited with a wide bandwidth of excitation.

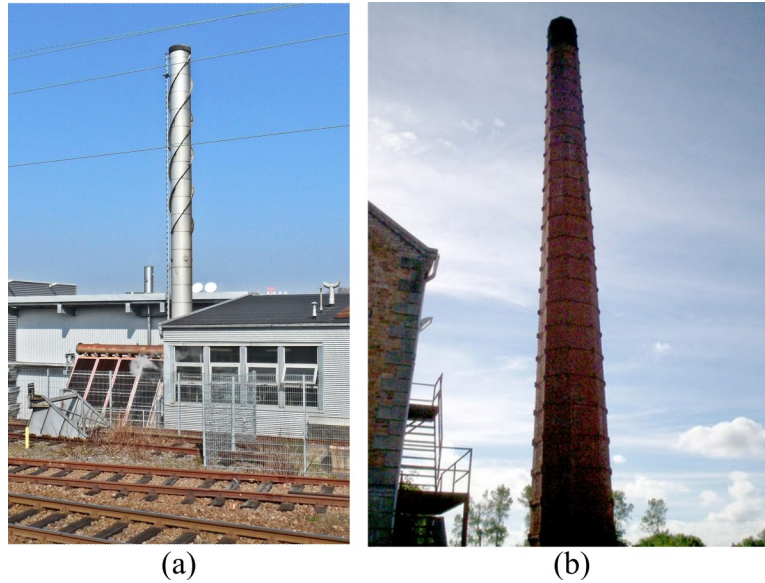

Figure 4.9: Methods used to reduce vortex-induced vibrations in smokestacks, showing: (a) helical steel strakes on a chimney stack^b, and; (b) Tapered chimney with wind bands at a Weaving Factory in the UK^c.

^aWang, Lei, and Xing-yan Fan. “Failure cases of high chimneys: A review.” *Engineering failure analysis* 105 (2019): 1107-1117.

^btromBer, CC BY-SA 3.0 <<https://creativecommons.org/licenses/by-sa/3.0/>>, via Wikimedia Commons

^cP Flannagan / Large Chimney Stack of the disused Weaving Factory, Donaghcloney. / CC BY-SA 2.0

4.3 System Response to Arbitrary Inputs

The time-domain response of a system to an arbitrary input force in time can be calculated using a series of impulses as shown in figure 4.10. This method allows the practitioner to easily calculate the response of an arbitrary input to a system using a single expression executed in a “for loop”. This type of analysis is often more efficient in terms of programming than more direct methods.

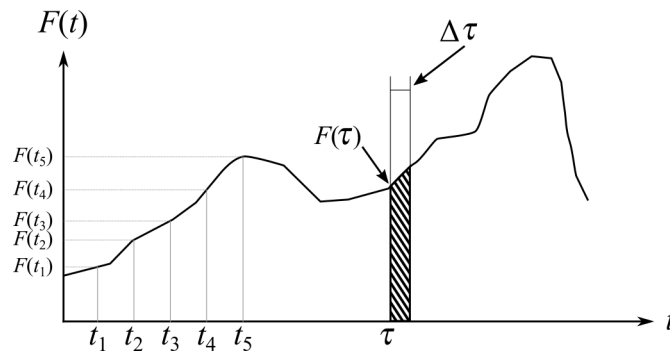

Figure 4.10: Generalized response showing that any signal can be represented as a series of impulse signals.

To solve for a generalized response to arbitrary inputs we will use our knowledge that we are dealing with linear systems and that the sequence of partial sums can be applied to from a solution from several impulse responses. First, we re-define the response of a 1 DOF system to a unit impulse load as

$$g(t) = x(t) = \frac{1}{m\omega_d} e^{-\zeta\omega_n t} \sin(\omega_d t) \quad (4.42)$$

by re-defining $x(t)$ as $g(t)$ we reserve the use of $x(t)$ for the final solution.

From figure 4.10, we can assume that at time τ a force defined as $F(\tau)$ acts on the system for a time $\Delta\tau$. Therefore, the impulse acting at time t is $F(\tau)\Delta\tau$. At any time in the future after the impulse that is applied at time τ , the time elapsed is $t - \tau$. Therefore, the response at any time t of the impulse event is found using equation 4.42 and is written as $g(t - \tau)$. As the impulse for this special case happens at $t = \tau$ instead of the traditional $t = 0$, the unit impulse response at any time $t - \tau$ can be expressed as

$$g(t - \tau) = \frac{1}{m\omega_d} e^{-\zeta\omega_n(t-\tau)} \sin(\omega_d(t - \tau)), \quad t \geq \tau \quad (4.43)$$

Again, using g as the response to a single impulse that makes up the arbitrary signal. To solve for the arbitrary input $F(t)$, a piece-wise expression is used; as demonstrated in example 4.2.

To define the integral form we first obtain the total response by summing all the individual impulse responses using the open-ended summation

$$x(t) = \sum F(\tau)g(t - \tau)\Delta\tau \quad (4.44)$$

Letting $\Delta\tau \rightarrow 0$, the summation can be transferred into the continuous integration

$$x(t) = \int_0^t F(\tau)g(t - \tau)d\tau \quad (4.45)$$

The integral in equation 4.45 is called a convolutional integral which is simply the integral of the produce of two functions where one of the functions is shifted by the variable of integration; in this case τ . Knowing the solution to an impulse load, re-defined as $g(t)$ in equation 4.42 we can expand out the expression in equation 4.45 such that the response of the total system is

$$x(t) = \frac{1}{m\omega_d} \int_0^t F(\tau) e^{-\zeta\omega_n(t-\tau)} \sin(\omega_d(t - \tau)) d\tau \quad (4.46)$$

Again, this represents the total system response (without initial conditions) for an arbitrary excitation $F(t)$. These equations are called the *Duhamel* integral. In many cases, the function $F(t)$ allows for explicit integration of equations 4.45 and 4.46. However, numerical evaluation using a piece-wise equation made up of equation 4.43 is always possible and many times easier given the simplicity of coding.

Example 4.2 Double Hammer Impact

In testing, a hammer is used to excite a 1-DOF system with an impact (i.e. impulse), however, the hammer impacts the system twice by ascendant (a double hit). The first impact has a force of 0.2 N, while the second has a force of 0.1 N and happens 0.1 seconds after the first impact. Plot the response for the double impact. The system has the parameters $m = 1$ kg, $c = 0.5$ kg/s, $k = 4$ N/m.

Solution: First, we can define the forcing function as:

$$F(t) = 0.2\delta(t) + 0.1\delta(t - \tau) \quad (4.47)$$

where τ is the offset between the first and second impacts. Next, considering that the unit impulse has a magnitude of 1 we can obtain solutions for the first impact by first writing its EOM:

$$m\ddot{x}(t) + c\dot{x}(t) + kx(t) = 0.2\delta(t) \quad (4.48)$$

Taking the Laplace transform of both sides of the equation yields

$$m(s^2X(s) - sx(0) - \dot{x}(0)) + c(sX(s) - x(0)) + kX(s) = 0.2 \quad (4.49)$$

However, assuming zero initial conditions, the equation simplifies to.

$$(ms^2 + cs + k)X(s) = 0.2 \quad (4.50)$$

Solving this equation for $X(s)$:

$$X(s) = \frac{0.2}{m} \cdot \frac{1}{s^2 + 2\zeta\omega_n s + \omega_n^2} \quad (4.51)$$

Again, consulting #10 in the table for Laplace transforms results in:

$$x_1(t) = \frac{0.2}{m\omega_d} e^{-\zeta\omega_n t} \sin(\omega_d t) \quad (4.52)$$

where this is the general solution for a damped system subjected to an impulse loading function. The second impact can now be solved for using the same method. However, now the time (t) must be offset by (τ) to allow the impact to still be located at $t = 0$ in terms of the second impact. This results in:

$$x_1(t) = \frac{0.2}{m\omega_d} e^{-\zeta\omega_n t} \sin(\omega_d t) \quad (4.53)$$

$$x_2(t) = \frac{0.1}{m\omega_d} e^{-\zeta\omega_n(t-\tau)} \sin(\omega_d(t-\tau)) \quad (4.54)$$

Using the knowledge that the systems are linear and that the Laplace transform of a linear combination of two transforms is the same as the linear transformation of these functions we can build the piecewise function:

$$x(t) = \begin{cases} \frac{0.2}{m\omega_d} e^{-\zeta\omega_n t} \sin(\omega_d t) & \text{if } t < \tau \\ \frac{0.2}{m\omega_d} e^{-\zeta\omega_n t} \sin(\omega_d t) + \frac{0.1}{m\omega_d} e^{-\zeta\omega_n(t-\tau)} \sin(\omega_d(t-\tau)) & \text{if } \tau \leq t \end{cases} \quad (4.55)$$

For the mass, damping, and stiffness values given above can be plotted as:

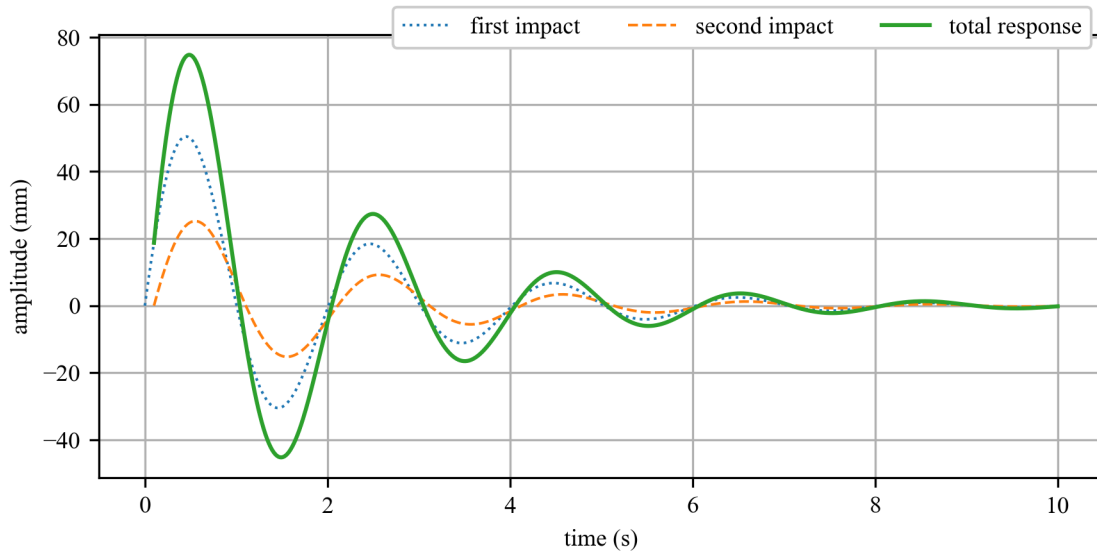

Example 4.3 Arbitrary Base Excitation

Consider the base excitation as shown below subjected to an arbitrary base excitation. Derive an equation (Duhamel integral) for its displacement (z), when the displacement is expressed at the relative displacement of the mass such that $z = x - y$.

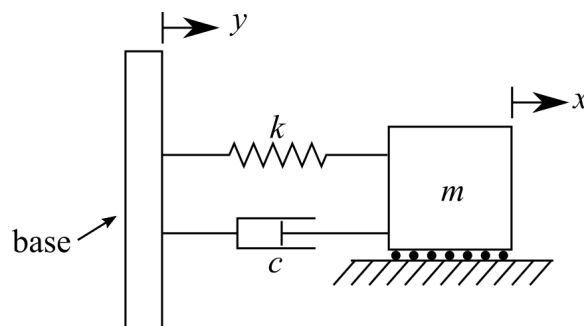

Figure 4.11: A base excited 1-DOF spring-mass-damper system.

Defining the EOM for the system results in

$$m\ddot{x} + c\dot{x} + kx = c\dot{y} + ky \quad (4.56)$$

Using $z = x - y$, this can be simplified to

$$m\ddot{z} + c\dot{z} + kz = -m\ddot{y} \quad (4.57)$$

Given that we can replace $-m\ddot{y}$ with F , this is the same equation as

$$m\ddot{z} + c\dot{z} + kz = F \quad (4.58)$$

meaning that the solutions for an arbitrary force-excited problem can transfer to a base-excited problem if we consider the relative displacement of the mass. Therefore, we can write the equation for the relative displacement of the mass as

$$z(t) = -\frac{1}{m\omega_d} \int_0^t \ddot{y}(\tau) e^{-\zeta\omega_n(t-\tau)} \sin(\omega_d(t-\tau)) d\tau \quad (4.59)$$

4.4 Transfer Function for Response to Random Inputs

Consider the following system

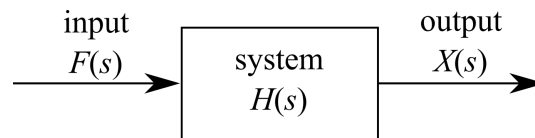

Figure 4.12: Generic block diagram of a system $H(s)$ subjected to an input $F(s)$ and its corresponding output $X(s)$ where the (s) denotes that the considered system is in the s -plane.

where $F(s)$ is the input, $H(s)$ is the system, and $X(s)$ is the output from the system. This formulation is called the transfer-function approach and is commonly used for the formulation and solution of dynamic problems in the control literature. It can also be used for solving various forced-vibration problems including those from complex or stochastic inputs.

4.4.1 Defining the Transfer Function $H(s)$

Again, consider the generic system represented in figure 4.12. For this system representation, $F(s)$ is the Laplace of the transform of the driving force, and $H(s)$ is the Laplace transform of the response of the system $h(t)$.

We need to define the transfer function $H(s)$ for a generic system. To do this let us show the reasoning behind the transfer function. Here we will show that the output of any system ($x(t)$) can be related to the input of the system ($f(t)$) through a series of polynomial coefficients (a and b). Consider the general n^{th} -order linear, time-invariant differential equation that governs the behavior of the dynamic system.

$$a_n \frac{d^n x(t)}{dt^n} + a_{n-1} \frac{d^{n-1} x(t)}{dt^{n-1}} + \dots + a_0 x(t) = b_m \frac{d^m f(t)}{dt^m} + b_{m-1} \frac{d^{m-1} f(t)}{dt^{m-1}} + \dots + b_0 f(t) \quad (4.60)$$

where $x(t)$ is the output and $f(t)$ is the input. Note that this is similar to the formulation we have had before for the EOM. Taking the Laplace transform of both sides of the above equation yields

$$\begin{aligned} a_n s^n X(s) + a_{n-1} s^{n-1} X(s) + \dots + a_0 X(s) + \text{initial condition for } x(t) = \\ b_m s^m F(s) + b_{m-1} s^{m-1} F(s) + \dots + b_0 F(s) + \text{initial condition for } f(t) \end{aligned} \quad (4.61)$$

It can be seen that this equation is a purely algebraic expression. If we assume the initial conditions to be zero, the equation reduces to the following:

$$(a_n s^n + a_{n-1} s^{n-1} + \dots + a_0) X(s) = (b_m s^m + b_{m-1} s^{m-1} + \dots + b_0) F(s) \quad (4.62)$$

if we rearrange equation 4.62 to solve for the relationship between the Laplace variables ($X(s)$ and $F(s)$) and the algebraic expressions we get:

$$\frac{X(s)}{F(s)} = \frac{b_m s^m + b_{m-1} s^{m-1} + \dots + b_0}{a_n s^n + a_{n-1} s^{n-1} + \dots + a_0} \quad (4.63)$$

this shows that the ratio of the input algebraic expressions over the output algebraic expressions is equal to the ratio of the output Laplace variable over the input Laplace variable. This shows that we can relate the Laplace variables to the algebraic expressions. Therefore, we can define the transfer function $H(s)$ as:

$$H(s) = \frac{X(s)}{F(s)} \quad (4.64)$$

In a more formal term, the transfer function is defined as: “The ratio of the Laplace transforms of the output or response function to the Laplace transform of the input or forcing function assuming zero initial conditions”.

Equation 4.64 can be rearranged to show that the output of the system $X(s)$, can be obtained if we know the input $F(s)$ and the transfer function $H(s)$:

$$X(s) = H(s)F(s) \quad (4.65)$$

4.4.2 Transfer Function Method (Steady-state Solution)

Considering the forced system:

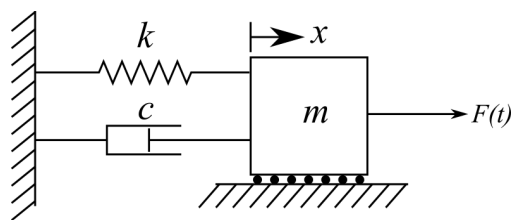

Figure 4.13: A spring-dashpot-mass model of a 1-DOF system with external excitation.

that can be expressed as the equation of motion

$$m\ddot{x}(t) + c\dot{x}(t) + kx(t) = F_0 \cos(\omega t) \quad (4.66)$$

Here $F_0 \cos(\omega t)$, is used at the input but any input will develop the same transfer function as the transfer function is bounded to the system and not the input. From the #6 in the table for Laplace Transforms, we know that

$$\mathcal{L}[\cos(\omega t)] = \frac{s}{s^2 + \omega^2} \quad (4.67)$$

Therefore,

$$F(s) = \frac{F_0 s}{s^2 + \omega^2} \quad (4.68)$$

Ignoring the initial conditions, and therefore considering only the particular solution, and taking the Laplace transform of the EOM equation yields:

$$(ms^2 + cs + k)X(s) = \frac{F_0 s}{s^2 + \omega^2} \quad (4.69)$$

where $X(s)$ denotes the Laplace transform of the unknown function $x(t)$ and s is the complex transform variable. Rearranging the above equation for $X(s)$ yields:

$$X(s) = \frac{F_0 s}{(ms^2 + cs + k)(s^2 + \omega^2)} \quad (4.70)$$

Now that we have $F(s)$ and $X(s)$ we can obtain $H(s)$ as

$$H(s) = \frac{X(s)}{F(s)} = \frac{F_0 s}{(ms^2 + cs + k)(s^2 + \omega^2)} \cdot \frac{s^2 + \omega^2}{F_0 s} = \frac{1}{ms^2 + cs + k} \quad (4.71)$$

or

$$H(s) = \frac{1}{ms^2 + cs + k} \quad (4.72)$$

This ratio is termed the transfer function of a system and is an important tool in vibration analysis.

Sometimes, how the system responds to an input with certain frequency components is important in understanding the system in general, therefore, we want to solve for the frequency response function of the system. The frequency response function is denoted as $H(j\omega)$ where the complex number s is replaced by the frequency component of the system while considering the imaginary portion in the complex plane (i.e., $s = j\omega$). Therefore, the frequency response function of the system becomes:

$$H(j\omega) = \frac{1}{m(j\omega)^2 + cj\omega + k} = \frac{1}{-m\omega^2 + cj\omega + k} \quad (4.73)$$

rearranging into a standard form yields:

$$H(j\omega) = \frac{1}{k - m\omega^2 + c\omega j} \quad (4.74)$$

recall that $j^2 = -1$. $H(j\omega)$ is the frequency response function of the system. The frequency response function of the system is the transfer function of the system evaluated in the complex

plane. As this expression contains imaginary values to account for the phase in the system it can be challenging to work with. The amplitude $|H(j\omega)|$ of the response (the real portion of the equation) is useful to the practitioner. Therefore, it is prudent to consider the special case of amplitude response while neglecting the phase response. Consider that:

$$H(j\omega) = R + Ij \quad (4.75)$$

so

$$|H(j\omega)| = \sqrt{R^2 + I^2} \quad (4.76)$$

multiplying $H(j\omega)$ by 1 that is represented by its unit complex conjugate yields:

$$H(j\omega) = \left(\frac{1}{k - m\omega^2 + c\omega j} \right) \left(\frac{k - m\omega^2 - c\omega j}{k - m\omega^2 - c\omega j} \right) \quad (4.77)$$

$$= \frac{k - m\omega^2 - c\omega j}{(k - m\omega^2)^2 + (c\omega)^2} \quad (4.78)$$

$$= \frac{k - m\omega^2}{(k - m\omega^2)^2 + (c\omega)^2} + \frac{-c\omega}{(k - m\omega^2)^2 + (c\omega)^2} j \quad (4.79)$$

therefore, $R = \frac{k - m\omega^2}{(k - m\omega^2)^2 + (c\omega)^2}$ and $I = \frac{-c\omega}{(k - m\omega^2)^2 + (c\omega)^2}$. Now, calculating the amplitude of $H(j\omega)$ we get:

$$H(\omega) = |H(j\omega)| \quad (4.80)$$

$$= \sqrt{R^2 + I^2} \quad (4.81)$$

$$= \sqrt{\frac{(k - m\omega)^2 + (-c\omega)^2}{((k - m\omega^2)^2 + (c\omega)^2)^2}} \quad (4.82)$$

$$= \sqrt{\frac{1}{(k - m\omega^2)^2 + c^2\omega^2}} \quad (4.83)$$

$$= \frac{1}{\sqrt{(k - m\omega^2)^2 + c^2\omega^2}} \quad (4.84)$$

where $H(\omega)$ represents only the amplitude of the frequency response function and therefore drops the j term from the expression.

Review 4.3 System Response Modeling using Transfer Functions

To recap, for a single DOF damped spring-mass system the transfer function is:

$$H(s) = \frac{1}{ms^2 + cs + k} \quad (4.85)$$

And the frequency response function is:

$$H(j\omega) = \frac{1}{k - m\omega^2 + c\omega j} \quad (4.86)$$

While the amplitude of the frequency response is:

$$H(\omega) = |H(j\omega)| = \frac{1}{\sqrt{(k - m\omega^2)^2 + c^2\omega^2}} \quad (4.87)$$

Example 4.4 Deriving Transfer Function for Forced System

Considering the forced system in figure 4.14 set the forcing function to be $F_0 \sin(\omega t)$ and calculate the transfer function.

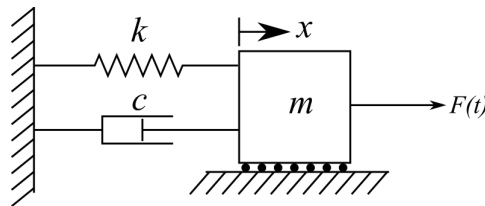

Figure 4.14: A spring-dashpot-mass model of a 1-DOF system with external excitation.

Solution:

The equation of motion for the system is:

$$m\ddot{x} + c\dot{x} + kx = F_0 \sin(\omega t) \quad (4.88)$$

From the #6 in the table for Laplace Transforms, we know that:

$$\mathcal{L}[\sin(\omega t)] = \frac{\omega}{s^2 + \omega^2} \quad (4.89)$$

Therefore,

$$F(s) = \frac{F_0 \omega}{s^2 + \omega^2} \quad (4.90)$$

Ignoring the initial conditions and taking the Laplace transform of the EOM equation yields:

$$(ms^2 + cs + k)X(s) = \frac{F_0 \omega}{s^2 + \omega^2} \quad (4.91)$$

Solving algebraically for the $X(s)$ yields:

$$X(s) = \frac{F_0 \omega}{(ms^2 + cs + k)(s^2 + \omega^2)} \quad (4.92)$$

Now that we have $F(s)$ and $X(s)$ we can obtain $H(s)$ as

$$H(s) = \frac{X(s)}{F(s)} = \frac{F_0 \omega}{(ms^2 + cs + k)(s^2 + \omega^2)} \cdot \frac{s^2 + \omega^2}{F_0 \omega} = \frac{1}{ms^2 + cs + k} \quad (4.93)$$

or

$$H(s) = \frac{1}{ms^2 + cs + k} \quad (4.94)$$

This is identical to the solution obtained using $F_0 \cos(\omega t)$ as would be expected because the transfer function is related to the system and not to the input.

Review 4.4 Frequency and Time Domains

The frequency domain is a mathematical representation of a signal or data in terms of its frequency components, as opposed to its temporal or time-based representation. The frequency domain provides a different perspective on the signal by decomposing it into its constituent sinusoidal signals at discrete frequencies and their respective magnitudes. A 3D representation of this process is shown in figure 4.15. The transformation between the time domain and the frequency domain is typically achieved using mathematical techniques such as the Fourier Transform or the Fast Fourier Transform (FFT).

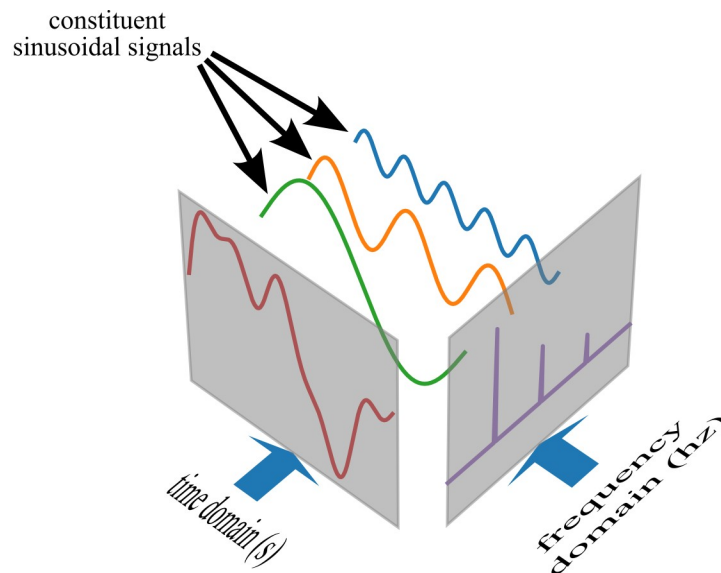

Figure 4.15: 3D visualization of time and frequency domains where a temporal signal is decomposed into constituent sinusoidal signals.

4.4.3 Response to Random Inputs

The transfer and frequency response functions can be very useful for determining the system's response to random inputs. Up to this point, we have solved for deterministic input.

- **Deterministic**-For a known time t , the value of the input force $F(t)$ is precisely known.
- **Random** For a known time t , the value of the input force $F(t)$ is known only statistically.

To expand, a random signal is a signal with no obvious pattern. For these types of signals, it is not possible to focus on the details of the input signal, as is done with a deterministic signal, rather the signal is classified and manipulated in terms of its statistical properties.

Randomness in vibration analysis can be thought of as the result of a series of results obtained from testing a system's repeatability for various inputs under varying conditions. In these cases, one record or time history is not enough to describe the system. Rather, an ensemble of various tests are used to describe how the system will respond to the various inputs.

First, let us consider two inputs, a deterministic input (typical sin wave), and a random input (white noise). These inputs are shown in figure 4.16.

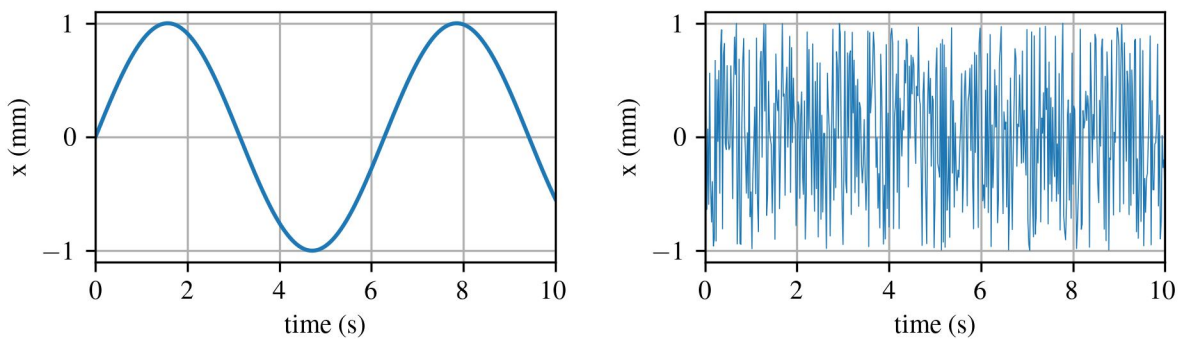

Figure 4.16: Two arbitrary inputs: (a) sinusoidal; and (b) uniform random noise.

One of the first factors to consider is the mean of the random signal $x(t)$, defined as:

$$E[x] = \bar{x} = \lim_{T \rightarrow \infty} \frac{1}{T} \int_0^T x(t) dt \quad (4.95)$$

where T is the length in time of the data collected. However, for random signals, we often want to consider signals with an average mean of zero (i.e. $\bar{x}(t) = 0$). For signals not centered around zero, we can obtain a zero-centered signal if the signal is stationary and we subtract the mean value \bar{x} from the signal $x(t)$. This can be written as:

$$x'(t) = x(t) - \bar{x} \quad (4.96)$$

where the $x'(t)$ is now centered around zero. As mentioned before, it is important to consider whether or not the input signals are stationary. A signal is stationary if its statistical properties (usually expressed by its mean) do not change with time. Here, it can be seen that for our inputs considered the signals are stationary if a long enough time period is considered.

Another important variable is the variance (or mean-square value) of the random variable $x(t)$ defined as:

$$E[(x - \bar{x})^2] = \lim_{T \rightarrow \infty} \frac{1}{T} \int_0^T (x(t) - \bar{x})^2 dt \quad (4.97)$$

and provides a measure of the magnitude of the fluctuations in the signal $x(t)$. If the signal has an expected value of zero, or $E[x] = 0$, this simplifies to.

$$E[x^2] = \bar{x^2} = \lim_{T \rightarrow \infty} \frac{1}{T} \int_0^T x^2(t) dt \quad (4.98)$$

This expression leads to the calculation of the root-mean-square (RMS) of the signal:

$$x_{\text{rms}} = \sqrt{\bar{x^2}} \quad (4.99)$$

Considering a nonstationary signal, an important measure of interest is how fast the value of the variables changes. This is important to understand as it provides context for how long a signal must be sampled before a meaningful representation of the signal can be calculated in a statistical sense. One way to quantify how fast the values of signal change is the autocorrelation function:

$$R_{xx}(\tau) = \lim_{T \rightarrow \infty} \frac{1}{T} \int_0^T x(t)x(t + \tau) dt \quad (4.100)$$

The subscript xx denotes that this is a measure of the response for the variable xx . τ is the time difference between the values at which the signal $x(t)$ is sampled and is different than the τ defined in section 4.3. The autocorrelation for the two inputs considered above is shown in figure 4.17.

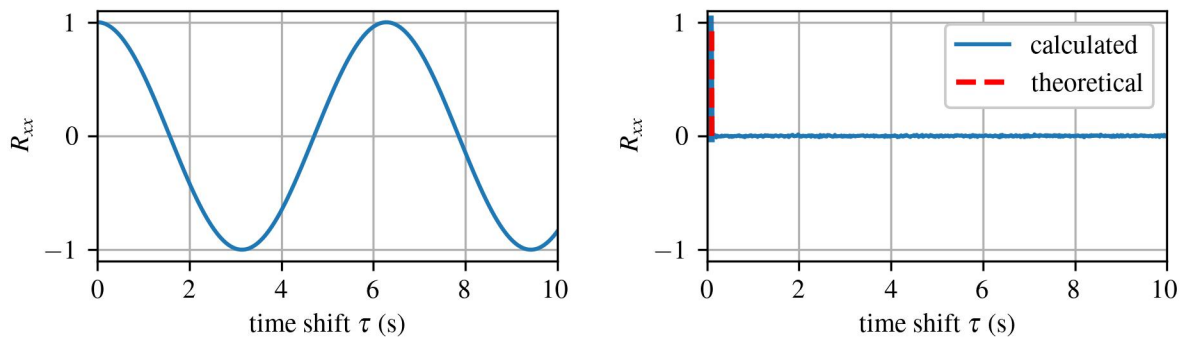

Figure 4.17: Responses from the autocorrelation function for the inputs shown in figure 4.16 showing: (a) a sinusoidal; and (b) uniform random noise.

NOTE

The value of τ selected in the autocorrelation function greatly affects its response for the sinusoidal input. This is because the values for the sinusoidal are highly correlated. To expand, the value at any time t is greatly affected by the values immediately before and after it. This is not the case for the random input where the signal is not correlated and therefore there is little difference in changing the value of τ on the response of the autocorrelation function.

If we take the Fourier transform of the autocorrelation function we obtain the power spectral density (PSD) defined as:

$$S_{xx}(\omega) = \frac{1}{2\pi} \int_{-\infty}^{\infty} R_{xx}(\tau) e^{-j\omega\tau} d\tau \quad (4.101)$$

where the integral of $R_{xx}(\tau)$ changes the real number τ into the frequency-domain value ω . The frequency spectrum is denoted with S and the subscript of the considered variable (e.g., $S_{xx}(\omega)$).

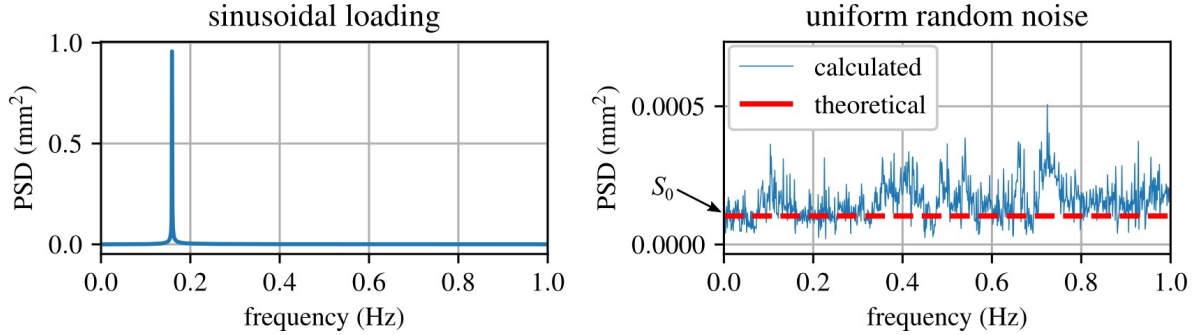

Figure 4.18: Power spectral density plots for the inputs shown in figure 4.16 showing: (a) a sinusoidal; and (b) uniform random noise.

The frequency spectrum for the two input cases considered are plotted in figure 4.18. where the flat frequency response for the random input denotes that the random input is white noise input. This flat frequency response in the frequency domain can be denoted S_0 , such that $S_{ff}(\omega) = S_0$ or $S_{xx}(\omega) = S_0$, depending on whether the frequency spectrum of the input (ff) or output (xx) is being considered. While a true white noise input would be perfectly flat, white noise is really just a theoretical concept as all real-world data will have some variation in the frequency domain as diagrammed in figure 4.18(b).

Recall that S_{xx} is the spectrum of the response of the system. For the one-DOF system considered here, we can express the arbitrary input as a series of impulse inputs as discussed in section 4.3. This knowledge, along with the frequency response function can be used to relate the spectrum of the input $S_{ff}(\omega)$ to the output through the transfer function as:

$$S_{xx}(\omega) = |H(j\omega)|^2 \left[\frac{1}{2\pi} \int_{-\infty}^{\infty} R_{ff}(\tau) e^{-j\omega\tau} d\tau \right] \quad (4.102)$$

This can also be expressed in symbolic form as:

$$S_{xx}(\omega) = |H(j\omega)|^2 S_{ff}(\omega) \quad (4.103)$$

where R_{ff} denotes the autocorrelation function of $F(t)$ and S_{ff} denotes the PSD of the forcing function $F(t)$. The notation $|H(j\omega)|^2$ is the square of the magnitude of the complex frequency response. A more detailed derivation can be found in Rao^a, Inman^b, or Newland^c, but here it is more important to study the results rather than the derivations.

^aSingiresu, S. Rao. "Mechanical vibrations". Boston, MA: Addison Wesley, 1995.

^bInman, Daniel J., and Ramesh Chandra Singh. "Engineering vibrations". Vol. 3. Englewood Cliffs, NJ: Prentice Hall, 1994.

^cNewland, David E. "Random vibrations, spectral & wavelet analysis." Longman Scientific & Technical (1993).

Example 4.5 Calculating the Power Spectral Density of a Forced System

Consider the system in figure 4.19 and calculate the PSD of the response $x(t)$ given that the PSD of the applied force $S_{ff}(\omega)$ is white noise.

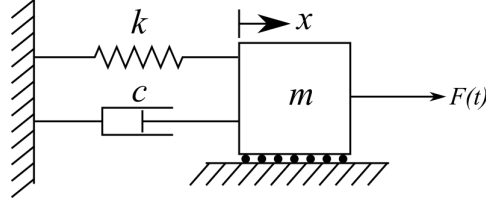

Figure 4.19: A spring-dashpot-mass model of a 1-DOF system with external excitation.

Solution:

From the system we know that the EOM is

$$m\ddot{x}(t) + c\dot{x}(t) + kx(t) = F(t) \quad (4.104)$$

The frequency response function for this system is

$$H(j\omega) = \frac{1}{k - m\omega^2 + c\omega j} \quad (4.105)$$

while the amplitude of the response is:

$$H(\omega) = |H(j\omega)| = \frac{1}{\sqrt{(k - m\omega^2)^2 + c^2\omega^2}} \quad (4.106)$$

Applying the equation that relates $S_{ff}(\omega)$ to $S_{xx}(\omega)$ we get:

$$S_{xx}(\omega) = |H(j\omega)|^2 S_{ff}(\omega) = \left| \frac{1}{k - m\omega^2 + c\omega j} \right|^2 S_{ff}(\omega) \quad (4.107)$$

White noise means the forcing function $S_{ff}(\omega)$ is constant across the frequency spectrum, therefore, $S_{ff}(\omega) = S_0$. Additionally as:

$$|H(j\omega)|^2 = \left| \frac{1}{k - m\omega^2 + c\omega j} \right|^2 = \frac{1}{(k - m\omega^2)^2 + c^2\omega^2} \quad (4.108)$$

where the absolute value is the amplitude of the system. Therefore, we obtain:

$$S_{xx}(\omega) = |H(j\omega)|^2 S_0 = \frac{1}{(k - m\omega^2)^2 + c^2\omega^2} S_0 = \frac{S_0}{(k - m\omega^2)^2 + c^2\omega^2} \quad (4.109)$$

Using various values for the elements in the system, the PSD for the system considered looks

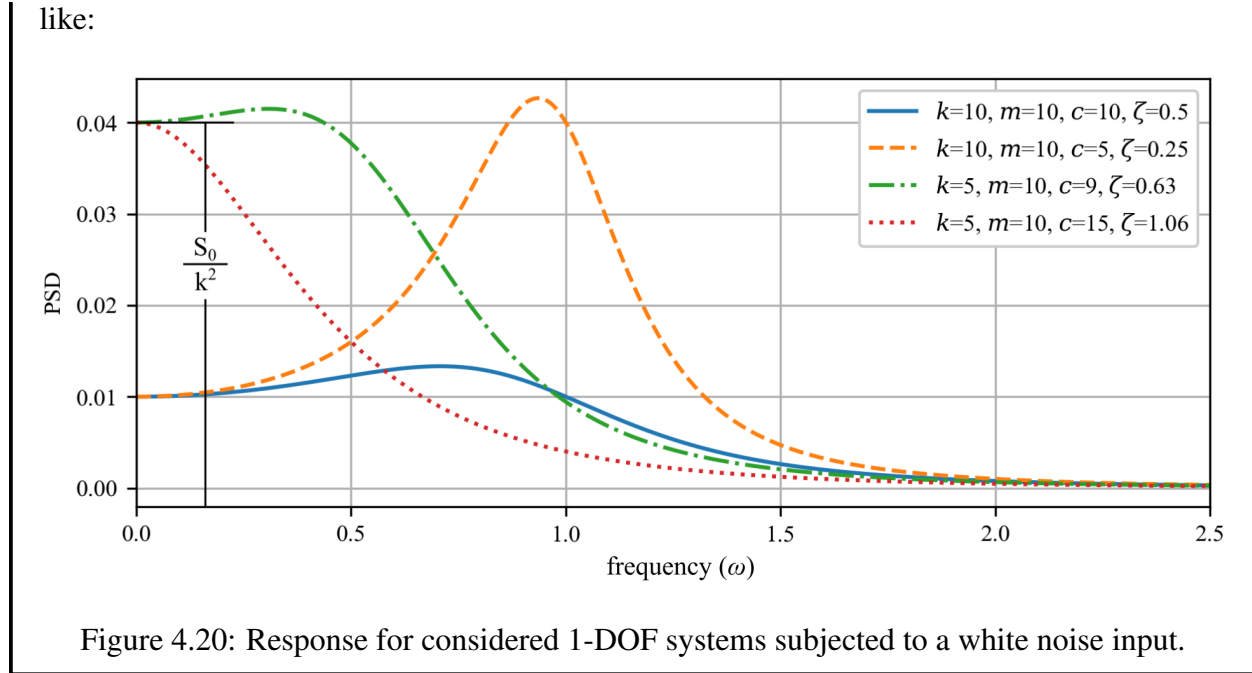

Another useful quantity to consider is the expected output, in terms of its mean and variance, for a given input. Working within the constraint that the system will oscillate about zero, $E[x] = 0$, the mean-square value can be directly related to the PSD function as:

$$E[x^2] = \overline{x^2} = \int_{-\infty}^{\infty} |H(j\omega)|^2 S_{ff}(\omega) d\omega \quad (4.110)$$

For a constant input S_0 , as diagrammed in figure 4.18(b), the mean-square value can be expressed as:

$$E[x^2] = \overline{x^2} = S_0 \int_{-\infty}^{\infty} |H(j\omega)|^2 d\omega \quad (4.111)$$

After inspecting the above equation, it becomes clear that to obtain the square of the expected value, a solution for $\int_{-\infty}^{\infty} |H(j\omega)|^2 d\omega$ must be obtained. For cases where $S_{ff}(\omega) = S_0$ and as such $S_{ff}(\omega)$ can be pulled out of the integral, these integrals have been solved^a. For example, given $\int_{-\infty}^{\infty} |H(j\omega)|^2 d\omega$:

$$\int_{-\infty}^{\infty} \left| \frac{B_0}{A_0 + j\omega A_1} \right|^2 d\omega = \frac{\pi B_0^2}{A_0 A_1} \quad (4.112)$$

and

$$\int_{-\infty}^{\infty} \left| \frac{B_0 + j\omega B_1}{A_0 + j\omega A_1 - \omega^2 A_2} \right|^2 d\omega = \frac{\pi(A_0 B_1^2 + A_2 B_0^2)}{A_0 A_1 A_2} \quad (4.113)$$

When combined with equation 4.111, these integrals allow for the easy calculation of the expected values.

^aNewland, David E. "Random vibrations, spectral & wavelet analysis." Longman Scientific & Technical (1993).

Example 4.6 Calculating the Mean-square Response of a Forced System

Consider the system in figure 4.19 and calculate the mean-square response of the system given that the spectrum of the input force $F(t)$ is a perfect theoretical white noise.

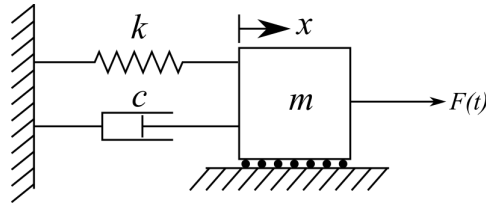

Figure 4.21: A spring-dashpot-mass model of a 1-DOF system with external excitation.

Solution:

Again, as the forcing function $S_{ff}(\omega)$ is constant across the frequency spectrum $S_{ff}(\omega) = S_0$ the mean-square response can be calculated as:

$$E[x^2] = \overline{x^2} = S_0 \int_{-\infty}^{\infty} |H(j\omega)|^2 d\omega \quad (4.114)$$

Using the already tabulated response:

$$\int_{-\infty}^{\infty} \left| \frac{B_0 + j\omega B_1}{A_0 + j\omega A_1 - \omega^2 A_2} \right|^2 d\omega = \frac{\pi(A_0 B_1^2 + A_2 B_0^2)}{A_0 A_1 A_2} \quad (4.115)$$

and the frequency response function for the system as derived in equation 4.74:

$$H(j\omega) = \frac{1}{k - m\omega^2 + c\omega j} \quad (4.116)$$

when $B_0 = 1$, $B_1 = 0$, $A_0 = k$, $A_1 = c$, and $A_2 = m$. Therefore, using the tabulated expression we can show that:

$$E[x^2] = S_0 \frac{\pi m}{kcm} = \frac{S_0 \pi}{kc} \quad (4.117)$$

Table of Laplace Transforms for Vibrations

This is a partial list of important Laplace transforms for vibrations and assumes zero initial conditions, $0 < t$, and $\zeta < 1$.

$f(t)$	$\mathcal{L}[f(t)] = F(s)$	$f(t)$	$\mathcal{L}[f(t)] = F(s)$
$\delta(t)$	1 (1)	$\frac{1}{\omega^3}(\omega t - \sin(\omega t))$	$\frac{1}{s^2(s^2 + \omega^2)}$ (17)
$\delta(t - t_0)$	e^{-st_0} (2)	$\frac{1}{2\omega^3}(\sin(\omega t) - \omega t \cos(\omega t)) \dots$	$\frac{1}{(s^2 + \omega^2)^2}$ (18)
1	$\frac{1}{s}$ (3)	$\frac{t}{2\omega} \sin(\omega t)$	$\frac{s}{(s^2 + \omega^2)^2}$ (19)
e^{at}	$\frac{1}{s - a}$ (4)	$t \sin(\omega t)$	$\frac{2\omega s}{(s^2 + \omega^2)^2}$ (20)
$\sin(\omega t)$	$\frac{\omega}{s^2 + \omega^2}$ (5)	$t \cos(\omega t)$	$\frac{s^2 - \omega^2}{(s^2 + \omega^2)^2}$ (21)
$\cos(\omega t)$	$\frac{s}{s^2 + \omega^2}$ (6)	$e^{at} \sin(\omega t)$	$\frac{\omega}{(s - a)^2 + \omega^2}$ (22)
$\sinh(\omega t)$	$\frac{\omega}{s^2 - \omega^2}$ (7)	$e^{at} \cos(\omega t)$	$\frac{s - a}{(s - a)^2 + \omega^2}$ (23)
$\cosh(\omega t)$	$\frac{s}{s^2 - \omega^2}$ (8)	$e^{at} \sinh(\omega t)$	$\frac{\omega}{(s - a)^2 - \omega^2}$ (24)
$\frac{1}{\omega^2}(1 - \cos(\omega t))$	$\frac{1}{s(s^2 + \omega^2)}$ (9)	$e^{at} \cosh(\omega t)$	$\frac{s - a}{(s - a)^2 - \omega^2}$ (25)
$\frac{1}{\omega_d} e^{-\zeta \omega t} \sin(\omega_d t)$	$\frac{1}{s^2 + 2\zeta \omega s + \omega^2}$ (10)	$\frac{1}{\omega_2} \sin(\omega_2 t) - \frac{1}{\omega_1} \sin(\omega_1 t) \dots$	$\frac{\omega_1^2 - \omega_2^2}{(s^2 + \omega_1^2)(s^2 + \omega_2^2)}$ (26)
$1 - \frac{\omega}{\omega_d} e^{-\zeta \omega t} \sin(\omega_d t + \phi), \phi = \cos^{-1}(\zeta) \dots$	$\frac{\omega^2}{s(s^2 + 2\zeta \omega s + \omega^2)}$ (11)	$\cos(\omega_2 t) - \cos(\omega_1 t)$	$\frac{s(\omega_1^2 - \omega_2^2)}{(s^2 + \omega_1^2)(s^2 + \omega_2^2)}$ (27)
$\frac{t^{n-1}}{(n-1)!}, n = 1, 2, \dots$	$\frac{1}{s^n}$ (12)	$e^{at} f(t)$	$F(s - a)$ (28)
$t^n, n = 1, 2, \dots$	$\frac{n!}{s^{n+1}}$ (13)	$f(t - a)\Phi(t - a)$	$e^{-as}F(s)$ (29)
$t^n e^{\omega t}, n = 1, 2, \dots$	$\frac{n!}{(s - \omega)^{n+1}}$ (14)	$\Phi(t - a)$	$\frac{e^{-as}}{s}$ (30)
$\frac{1}{\omega}(1 - e^{-\omega t})$	$\frac{1}{s(s + \omega)}$ (15)	$f'(t)$	$sF(s) - f(0)$ (31)
$\frac{1}{\omega^2}(e^{-\omega t} + \omega t - 1)$	$\frac{1}{s^2(s + \omega)}$ (16)		

5 Multiple Degree-of-freedom Systems

Until now we have only considered and modeled systems that can require one coordinate system to describe their motion. In this chapter, we will develop the mathematical tools required to model multiple degree-of-freedom systems that require multiple independent coordinates to describe their motion. As before, the equations that describe the motion of rigid bodies in space are developed from Newton's second law of motion. However, unlike before, there exists an independent equation for each body in motion. These equations are therefore coupled by the system and are often expressed in matrix notation such that the mass, damping, and stiffness matrices are easily defined.

Review 5.1 Linear Algebra

Linear algebra allows for the efficient solving of these coupled equations. In this text, matrices are expressed as bold capital letters (\mathbf{X}), vectors are denoted with an arrow (\vec{x}), and scalars/variables with italic letters (x). However, given the range of notation needed, it is not always possible to strictly follow this formulation.

The dot product allows us to multiply matrices and is defined as:

$$\begin{bmatrix} a & b \\ c & d \end{bmatrix} \begin{bmatrix} e \\ f \end{bmatrix} = \begin{bmatrix} ae + bf \\ ce + df \end{bmatrix} \quad (5.1)$$

Another arrangement of the same principle, in a format more related to vibrations, is:

$$\begin{bmatrix} a_1 + a_2 & b \\ c & d \end{bmatrix} \begin{bmatrix} e \\ f \end{bmatrix} = \begin{bmatrix} (a_1 + a_2)e + bf \\ ce + df \end{bmatrix} \quad (5.2)$$

The transpose of a matrix is an operator which flips a matrix over its diagonal. For a matrix \mathbf{A} , the transpose \mathbf{A}^T can be written as:

$$\mathbf{A} = \begin{bmatrix} a & b \\ c & d \\ e & f \end{bmatrix} \rightarrow \mathbf{A}^T = \begin{bmatrix} a & c & e \\ b & d & f \end{bmatrix} \quad (5.3)$$

A matrix is symmetric if $\mathbf{A} = \mathbf{A}^T$. Therefore, the symmetric matrix must be square and can be written as:

$$\mathbf{A} = \begin{bmatrix} a & b & c \\ d & e & f \\ g & h & i \end{bmatrix} = \mathbf{A}^T = \begin{bmatrix} a & d & g \\ b & e & h \\ c & f & i \end{bmatrix}, \text{ where } b = d, c = g, f = h \quad (5.4)$$

The determinant of a matrix is a scalar value that is a function of the entries of a square matrix. The determinant characterizes the matrix and its linear map. The determinant is often written as $\det(\mathbf{A})$, $\det \mathbf{A}$, or $|\mathbf{A}|$. For a 2×2 matrix this is defined as:

$$\det(\mathbf{A}) = ad - bc, \text{ when } \mathbf{A} = \begin{bmatrix} a & b \\ c & d \end{bmatrix} \quad (5.5)$$

The inverse of a square matrix is such that $\mathbf{A}\mathbf{A}^{-1} = \mathbf{A}^{-1}\mathbf{A} = \mathbf{I}$ where \mathbf{I} is the identity matrix:

$$\mathbf{I} = \begin{bmatrix} 1 & 0 \\ 0 & 1 \end{bmatrix} \quad (5.6)$$

and the inverse of a 2×2 matrix is defined as:

$$\mathbf{A}^{-1} = \frac{1}{\det(\mathbf{A})} \begin{bmatrix} d & -b \\ -c & a \end{bmatrix}, \text{ when } \mathbf{A} = \begin{bmatrix} a & b \\ c & d \end{bmatrix} \quad (5.7)$$

A matrix that does not have an inverse is called a singular matrix.

5.1 General Discussion on Mode Shapes

Studying and characterizing the natural frequencies of a system allows for the detailed investigation of the system response. Modern vibration analysis relies heavily on the concepts of mode shapes for various engineering tasks. Practical applications of the study of mode shapes (often called experimental modal analysis) include

- Correlation Finite Element Analysis with structures
- Structural Dynamic Modification
- Reduction of Finite Element Analysis models
- Forced Response Prediction
- Active Vibration Control

Vibration Case Study 5.1 Modal Testing

In automotive engineering, the requirements for safe and comfortable vehicles necessitate the need for a thorough understanding of the vehicle's dynamic properties and how any design changes affect its dynamics. Experimental modal analysis is an important troubleshooting and model-updating tool in the study of vehicle noise and vibration harshness (NVH). Oftentimes, experimental modal analysis is performed on a "body in white" or a sub-frame structure to develop a better understanding of the dynamics of the structure. Overall, experimental modal analysis is an important tool used in improving a vehicle's NVH performance.



Figure 5.1: Experimental modal analysis of an automotive (Jaguar) body in white, typically done to reduce vehicle noise and vibration harshness ^a.

^aCjp24, CC BY-SA 3.0 <<https://creativecommons.org/licenses/by-sa/3.0/>>, via Wikimedia Commons

Mode shapes are not the displacement of a system, rather they describe the configurations into which a structure will naturally displace at a given frequency. For example, consider the 4-DOF system shown in figure 5.2 that represents a pole (i.e. cantilever beam). Assuming that the system experiences a linear response and using the mode-superposition method we can see that the displaced shape \vec{x} is a function of all of the mode shapes u_i and their corresponding participation factors q_i . Note that the mode shapes associated with the lower frequencies tend to provide the greatest contribution to structural response. As the frequencies that excite the modes increase, the mode shapes contribute less, are predicted less reliably, and are harder to measure. Therefore, the analysis of the system is often truncated after the first few modes and rarely exceeds the 10th mode.

Figure 5.2 shows a structure with N degrees of freedom that therefore had N corresponding mode shapes. Each mode shape is independent and normalized such that the maximum displacements are the same. The summation of the mode shapes multiplied by their corresponding participation factors (q_i) yields the deflection of the structure.

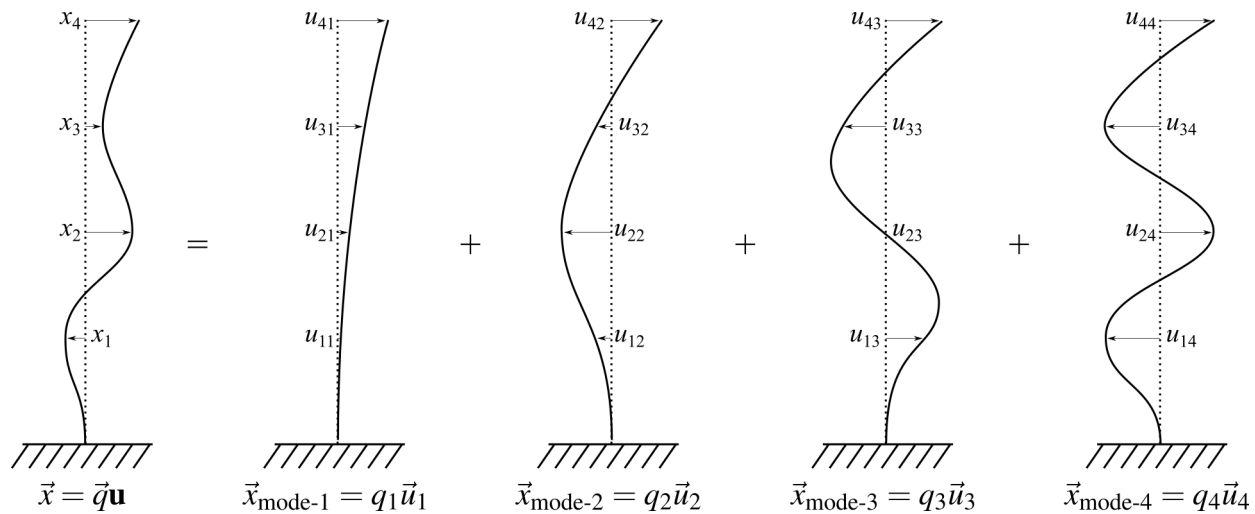

Figure 5.2: Deflection of a vertical cantilever, \vec{x} , is a function of the considered mode shapes u_i and their corresponding participation factors q_i .

5.2 Modeling Undamped Two- Degree-of-Freedom Systems

Consider the undamped 2-DOF systems presented in figure 5.3. This system with a single mass capable of moving in two directions. To expand, figure 5.3(a) reports a mass that can move horizontally or vertically in space. However, this mass does not rotate during its movements. Moreover, figure 5.3(b) presents a system that rotates about the spring and displaces vertically. These are examples of 2 DOF systems because each system has two independent coordinate systems that express the movement of the mass.

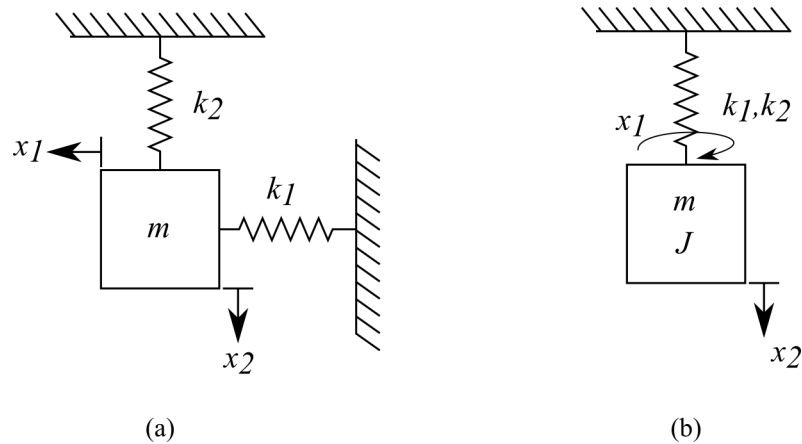

Figure 5.3: Examples of single mass 2-DOF systems that: (a) displaces in the vertical and horizontal directions, and; (b) rotates about the spring and displaces in the vertical direction.

Another example of a 2-DOF system with two masses, each with their own independent coordinate system, is presented in figure 5.4. The two coordinates that describe the system's movements are x_1 and x_2 .

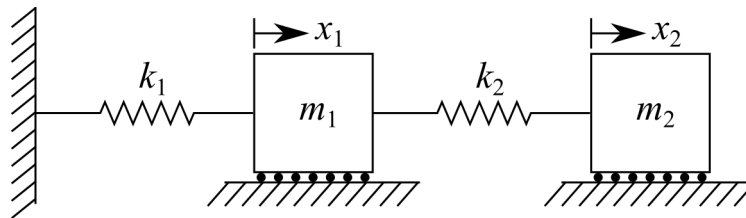

Figure 5.4: 2-DOF system with two masses and two independent coordinate systems x_1 and x_2 .

5.2.1 Solution for Two-Degree-of-Freedom Systems

Before we derive a model for undamped 2-DOF systems, let us first consider the solution to the system shown in figure 5.4. The solution consists of two equations, one for each mass. This solution will be derived in section 5.2.2 and is expressed by the coupled equations:

$$x_1(t) = A_1 \sin(\omega_1 t + \phi_1) u_{11} + A_2 \sin(\omega_2 t + \phi_2) u_{12} \quad (5.8)$$

$$x_2(t) = A_1 \sin(\omega_1 t + \phi_1) u_{21} + A_2 \sin(\omega_2 t + \phi_2) u_{22}, \quad \omega_1 \text{ or } \omega_2 \neq 0$$

These two equations can be written as a single equation in matrix form as:

$$\vec{x}(t) = A_1 \sin(\omega_1 t + \phi_1) \vec{u}_1 + A_2 \sin(\omega_2 t + \phi_2) \vec{u}_2, \quad \omega_1 \text{ or } \omega_2 \neq 0 \quad (5.9)$$

Where the arrow above the variable denotes a vector. Therefore, the vectors \vec{u}_1 and \vec{u}_2 are the mathematical expressions that “couple” or tie the equations together. Expanding these vectors shows:

$$\vec{x}(t) = \begin{bmatrix} x_1(t) \\ x_2(t) \end{bmatrix}, \quad \vec{u}_1 = \begin{bmatrix} u_{11} \\ u_{21} \end{bmatrix}, \quad \vec{u}_2 = \begin{bmatrix} u_{12} \\ u_{22} \end{bmatrix} \quad (5.10)$$

The four key components of the solution expressed in equation 5.9 are:

1. ω_1 and ω_2 are the natural frequencies of the system. They are not the frequencies of the masses. The solution states that each of the masses oscillates at the two frequencies ω_1 and ω_2 . Moreover, consider the special case where the initial conditions are selected to force $A_2 = 0$, in this case, each mass would only oscillate at only one frequency, ω_1 .
2. A_1 and A_2 are the constants of integration and determine the amplitude of the system.
3. ϕ_1 and ϕ_2 represent the phase shift of the system
4. \vec{u}_1 and \vec{u}_2 are the first and second mode shapes of the system and couple the system together.

5.2.2 Deriving the Solution for Two-Degree-of-Freedom Systems

To derive this solution for the system under consideration an FBD for figure 5.4 can be constructed for the forces acting on each mass. First we have to make the assumption that $x_1 < x_2$, this allows us to say that m_2 pulls on m_1 and results figure 5.5.

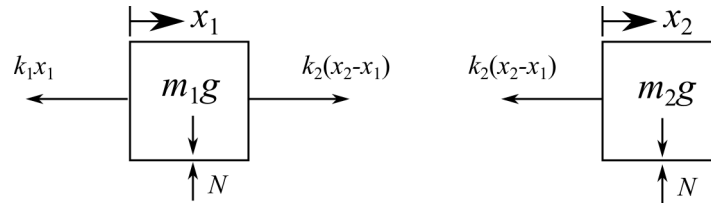

Figure 5.5: Free body diagram for the 2-DOF system presented in figure 5.4.

Applying Newton's second law and summing the forces on each mass in the horizontal direction yields:

$$\begin{aligned} m_1 \ddot{x}_1 &= -k_1 x_1 + k_2 (x_2 - x_1) \\ m_2 \ddot{x}_2 &= -k_2 (x_2 - x_1) \end{aligned} \quad (5.11)$$

These equations can be rearranged in terms of x_1 and x_2 as:

$$\begin{aligned} m_1 \ddot{x}_1 + (k_1 + k_2)x_1 - k_2 x_2 &= 0 \\ m_2 \ddot{x}_2 - k_2 x_1 + k_2 x_2 &= 0 \end{aligned} \quad (5.12)$$

where these are two coupled second-order differential equations that each require two initial conditions to solve. These initial conditions can be obtained from the displacement and velocity terms as:

$$\begin{aligned} x_1(0) &= x_{10} \\ \dot{x}_1(0) &= \dot{x}_{10} = v_{10} \\ x_2(0) &= x_{20} \\ \dot{x}_2(0) &= \dot{x}_{20} = v_{20} \end{aligned} \quad (5.13)$$

As before, these initial conditions will be the constants of integration used to solve the two second-order differential equations. This solution will provide the free response of each mass in the system.

There is a multitude of ways to solve these two coupled second-order differential equations, however, here we will just consider a matrix notation solution. This matrix notation solution is used as this formulation is readably solved using computers and is expandable to more than 2 DOF.

To initiate the solution, let us first develop the matrix formulation of the two coupled ODEs:

$$\begin{bmatrix} m_1 & 0 \\ 0 & m_2 \end{bmatrix} \begin{bmatrix} \ddot{x}_1 \\ \ddot{x}_2 \end{bmatrix} + \begin{bmatrix} k_1 + k_2 & -k_2 \\ -k_2 & k_2 \end{bmatrix} \begin{bmatrix} x_1 \\ x_2 \end{bmatrix} = \begin{bmatrix} 0 \\ 0 \end{bmatrix} \quad (5.14)$$

This equation can also be expressed as the vector equation:

$$M\ddot{\vec{x}} + K\vec{x} = 0 \quad (5.15)$$

and is known as the EOM in vector form. In this formulation, the mass matrix (M) is defined as:

$$M = \begin{bmatrix} m_1 & 0 \\ 0 & m_2 \end{bmatrix} \quad (5.16)$$

while the stiffness matrix (K) is:

$$K = \begin{bmatrix} k_1 + k_2 & -k_2 \\ -k_2 & k_2 \end{bmatrix} \quad (5.17)$$

along with the displacement, velocity, and acceleration matrices:

$$\vec{x} = \begin{bmatrix} x_1 \\ x_2 \end{bmatrix}, \quad \dot{\vec{x}} = \begin{bmatrix} \dot{x}_1 \\ \dot{x}_2 \end{bmatrix}, \quad \ddot{\vec{x}} = \begin{bmatrix} \ddot{x}_1 \\ \ddot{x}_2 \end{bmatrix} \quad (5.18)$$

Beyond these equations, we can write the initial conditions as:

$$\vec{x}_0 = \begin{bmatrix} x_1(0) \\ x_2(0) \end{bmatrix}, \quad \dot{\vec{x}}_0 = \begin{bmatrix} \dot{x}_1(0) \\ \dot{x}_2(0) \end{bmatrix} \quad (5.19)$$

This simple connection between vibration analysis and matrix analysis allows computers to be used to solve large and complicated vibration problems quickly.

Recall that the 1-DOF version of the equation of motion was solved by calculating the values of the constants in an assumed harmonic solution. The same approach is applied here in order to solve for the displacement of the two-DOF system. This time, the solution is assumed in the form:

$$\vec{x}(t) = \vec{u}e^{j\omega t} \quad (5.20)$$

where \vec{u} is a vector of constants to be determined and can be written as:

$$\vec{u} = \begin{bmatrix} u_1 \\ u_2 \end{bmatrix} \quad (5.21)$$

From before, ω is also a constant to be determined. Again, $j = \sqrt{-1}$. In the same manner as before, $e^{j\omega t}$ represents harmonic motion as $e^{j\omega t} = \cos(\omega t) + j\sin(\omega t)$. Taking the derivatives of $\vec{x}(t) = \vec{u}e^{j\omega t}$ yields:

$$\dot{\vec{x}}(t) = j\omega\vec{u}e^{j\omega t} \quad (5.22)$$

$$\ddot{\vec{x}}(t) = -\omega^2 \vec{u} e^{j\omega t} \quad (5.23)$$

Substituting this into the EOM in vector form ($M\ddot{\vec{x}} + K\vec{x} = 0$) yields:

$$-\omega^2 M \vec{u} e^{j\omega t} + K \vec{u} e^{j\omega t} = 0 \quad (5.24)$$

or

$$(-\omega^2 M + K) \vec{u} e^{j\omega t} = 0 \quad (5.25)$$

As $e^{j\omega t} \neq 0$ for any value of t and not allowing \vec{u} to be zero it can be demerited that $(-\omega^2 M + K)$ must satisfy the vector equation. Therefore,

$$(-\omega^2 M + K) \vec{u} = 0, \quad \vec{u} \neq 0 \quad (5.26)$$

This forms a homogeneous set of algebraic equations. To be useful, these equations have a nonzero solution for the system must exist. For this to be true, the inverse of the coefficient matrix $(-\omega^2 M + K)$ must not exist. To expand, assume that the inverse of $(-\omega^2 M + K)$ does exist, by multiplying both sides of the equation by $(-\omega^2 M + K)^{-1}$ yields $\vec{u} = 0$. This is a trivial solution (it is not useful) as no motion in the system is implied. Therefore, the logical connection can be drawn between the solution of the equation and the inverse of the coefficient matrix $(-\omega^2 M + K)$.

Applying the singularity condition to the coefficient matrix of equation $(-\omega^2 M + K) \vec{u} = 0$, $\vec{u} \neq 0$ results a nonzero solution of \vec{u} . However, for this to exist the following must be true:

$$\det(-\omega^2 M + K) = 0 \quad (5.27)$$

Solving this expression results in one algebraic equation with one unknown (ω). Expanding the above equation to consider the values for the matrices M and K results in:

$$\det \begin{bmatrix} -\omega^2 m_1 + k_1 + k_2 & -k_2 \\ -k_2 & -\omega^2 m_2 + k_2 \end{bmatrix} = 0 \quad (5.28)$$

Using the definition of the determinant yields that the unknown quantity ω^2 must satisfy:

$$m_1 m_2 \omega^4 - (m_1 k_2 + m_2 k_1 + m_2 k_2) \omega^2 + k_1 k_2 = 0 \quad (5.29)$$

This expression is called the characteristic equation for the system and is used to determine the constants $\omega_{1,2}$, in the assumed form of the solution given by the assumed solution $\vec{x}(t) = \vec{u} e^{j\omega t}$, once the values of the physical parameters m_1 , m_2 , k_1 , and k_2 are known. Note that $\omega_{1,2}$ are not in the characteristic equation, therefore, solving for $\omega_{1,2}$ will be done by factoring the equation above to obtain two solutions ω_1 and ω_2 . The characteristic equation is in the form of the quadratic formula if you set $x = \omega^2$, as:

$$ax^2 + bx + c = 0 \quad (5.30)$$

After finding the value of $\omega_{1,2}$ using the characteristic equation, the values in \vec{u} can be found using equation $(-\omega^2 M + K) \vec{u} = 0$, $\vec{u} \neq 0$ for each value of ω^2 . That is, for both ω_1 and ω_2 there is a vector \vec{u} that satisfies the equation. These solutions can be written as:

$$(-\omega_1^2 M + K) \vec{u}_1 = 0 \quad (5.31)$$

and

$$(-\omega_2^2 M + K)\vec{u}_2 = 0 \quad (5.32)$$

The direction of the vectors \vec{u}_1 and \vec{u}_2 can be obtained by solving the above expressions, however, the information regarding the magnitude of is not contained in this expression. To verify this, assume that \vec{u}_1 satisfies the equation, therefore, the vector $a\vec{u}_1$ also satisfies the equation where a is any nonzero number. Hence the vectors satisfying the above are of arbitrary magnitude.

The values obtained for \vec{u}_1 and \vec{u}_2 can now be combined with the assumed solution:

$$\vec{x}(t) = \vec{u}e^{j\omega t} \quad (5.33)$$

to form a set of solutions:

$$\vec{x}(t) = \vec{u}_1 e^{-j\omega_1 t}, \quad \vec{u}_1 e^{j\omega_1 t}, \quad \vec{u}_2 e^{-j\omega_2 t}, \quad \vec{u}_2 e^{j\omega_2 t} \quad (5.34)$$

Since the equation to be solved is linear, the solution is the sum of these solutions. This results in:

$$\vec{x}(t) = (ae^{j\omega_1 t} + be^{-j\omega_1 t})\vec{u}_1 + (ce^{j\omega_2 t} + de^{-j\omega_2 t})\vec{u}_2 \quad (5.35)$$

where a , b , c , and d are the arbitrary constants of integration to be determined by the initial conditions. Applying Euler's formulas for the sin functions (where ω_1 or $\omega_2 \neq 0$) reorganizes this equation as:

$$\vec{x}(t) = A_1 \sin(\omega_1 t + \phi_1)\vec{u}_1 + A_2 \sin(\omega_2 t + \phi_2)\vec{u}_2, \quad \omega_1 \text{ or } \omega_2 \neq 0 \quad (5.36)$$

Another way to write this equation is in the form:

$$\begin{bmatrix} x_1(t) \\ x_2(t) \end{bmatrix} = \begin{bmatrix} \vec{u}_1 & \vec{u}_2 \end{bmatrix} \begin{bmatrix} A_1 \sin(\omega_1 t + \phi_1) \\ A_2 \sin(\omega_2 t + \phi_2) \end{bmatrix}, \quad \omega_1 \text{ or } \omega_2 \neq 0 \quad (5.37)$$

Where the values for A_1 and A_2 can be obtained by setting applying the boundary conditions and taking the derivatives of the equations as done in the 1-DOF problems.

The final form of the equation provides physical insight into the solution of the system. It states that each mass in the system oscillates at both of the natural frequencies of the system (ω_1 and ω_2). Furthermore, the importance of the initial conditions can be understood. Assume that initial conditions are chosen that result in $A_2 = 0$, this cancels out the second natural frequency such that each mass oscillates at only one frequency, ω_1 . Moreover, the positions of the masses can be determined by the values of the vector \vec{u}_1 at any given time. For this reason, \vec{u}_1 is termed the first mode shape of the system. Likewise, if the opposite initial conditions are chosen such that $A_1 = 0$, then both system coordinates (e.g., masses in the systems we have studied) will oscillate at ω_2 and again, the positions can be obtained from the vector \vec{u}_2 . Where \vec{u}_2 is termed the second mode shape. The interactions between mode shapes and natural frequencies are very important and form the basis of several areas in the field of vibrations.

Example 5.1 Calculating Response of a two-DOF system

Considering the following system:

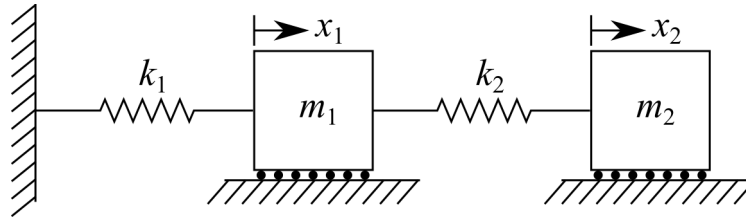

Figure 5.6: 2-DOF system with two masses and two independent confidante systems x_1 and x_2 .

Calculate response for the system if $m_1=9$ kg, $m_2=1$ kg, $k_1 = 24$ N/m, and $k_2 = 3$ N/m with the initial conditions $x_{10} = 1$ mm, $v_{10} = 0$ mm/s, $x_{20} = 0$ mm, and $v_{20} = 0$ mm/s.

Solution:

We have already obtained a characteristic equation for this system. This is shown in Equation 5.29 and is given as:

$$m_1 m_2 \omega^4 - (m_1 k_2 + m_2 k_1 + m_2 k_2) \omega^2 + k_1 k_2 = 0 \quad (5.38)$$

Substituting our values into this obtains:

$$9 \cdot 1 \omega^4 - (9 \cdot 3 + 1 \cdot 24 + 1 \cdot 3) \omega^2 + 24 \cdot 3 = 0 \quad (5.39)$$

or

$$\omega^4 - 6\omega^2 + 8 = 0 \quad (5.40)$$

This can then be factored into:

$$(\omega^2 - 2)(\omega^2 - 4) = 0 \quad (5.41)$$

This results in solutions of $\omega_1^2 = 2$ and $\omega_2^2 = 4$. Leading to:

$$\omega_1 = \pm\sqrt{2} \text{ rad/sec}, \quad \omega_2 = \pm 2 \text{ rad/sec} \quad (5.42)$$

We need to obtain solutions for \vec{u}_1 and \vec{u}_2 . Having solved for ω_1 and ω_2 we can obtain this. First, knowing $\vec{u}_1 = [u_{11} u_{21}]^T$ and using $\omega_1 = \sqrt{2}$ and the following equation:

$$(-\omega_1^2 M + K) \vec{u}_1 = 0 \quad (5.43)$$

yields simplified to

$$\left(-2 \begin{bmatrix} 9 & 0 \\ 0 & 1 \end{bmatrix} + \begin{bmatrix} 24+3 & -3 \\ -3 & 3 \end{bmatrix} \right) \begin{bmatrix} u_{11} \\ u_{21} \end{bmatrix} = \begin{bmatrix} 0 \\ 0 \end{bmatrix} \quad (5.44)$$

simplified to

$$\begin{bmatrix} 27 - 9 \cdot 2 & -3 \\ -3 & 3 - 2 \end{bmatrix} \begin{bmatrix} u_{11} \\ u_{21} \end{bmatrix} = \begin{bmatrix} 0 \\ 0 \end{bmatrix} \quad (5.45)$$

or

$$\begin{bmatrix} 9 & -3 \\ -3 & 1 \end{bmatrix} \begin{bmatrix} u_{11} \\ u_{21} \end{bmatrix} = \begin{bmatrix} 0 \\ 0 \end{bmatrix} \quad (5.46)$$

Taking the dot product of the matrix equation yields:

$$9u_{11} - 3u_{21} = 0, \text{ and } -3u_{12} + u_{22} = 0 \quad (5.47)$$

Both of these equations yield the same equation, that is:

$$\frac{u_{11}}{u_{21}} = \frac{1}{3} \quad (5.48)$$

As mentioned before, only the ratio of the elements is determined here. To show this is true it is easily seen that:

$$u_{11} = u_{21} \frac{1}{3} \rightarrow au_{11} = au_{21} \frac{1}{3} \quad (5.49)$$

To obtain a numerical value, we arbitrarily assign a value to one of the elements. Here, let $u_{21} = 1$ so let $u_{11} = 1/3$. Therefore,

$$\vec{u}_1 = \begin{bmatrix} \frac{1}{3} \\ 1 \end{bmatrix} \quad (5.50)$$

The same processes can be used for obtaining \vec{u}_2 using $\omega_2 = 2$, this results in:

$$\begin{bmatrix} -9 & -3 \\ -3 & -1 \end{bmatrix} \begin{bmatrix} u_{12} \\ u_{22} \end{bmatrix} = \begin{bmatrix} 0 \\ 0 \end{bmatrix} \quad (5.51)$$

Taking the dot product of the matrix equation yields:

$$-9u_{12} - 3u_{22} = 0, \text{ and } -3u_{12} - u_{22} = 0 \quad (5.52)$$

Both of these equations yield the same equation, that is:

$$\frac{u_{12}}{u_{22}} = -\frac{1}{3} \quad (5.53)$$

Again, assuming $u_{22} = 1$ this can be rearranged into \vec{u}_2 as:

$$\vec{u}_2 = \begin{bmatrix} -\frac{1}{3} \\ 1 \end{bmatrix} \quad (5.54)$$

Where \vec{u}_1 and \vec{u}_2 represent only the directions and shape of the mode shapes and not the magnitude of the mode shapes.

Now that we have the mode shapes, we can solve for the initial conditions A_1 and A_2 . To do this, let us use the following formulation of the solution:

$$\begin{bmatrix} x_1(t) \\ x_2(t) \end{bmatrix} = [\vec{u}_1 \quad \vec{u}_2] \begin{bmatrix} A_1 \sin(\omega_1 t + \phi_1) \\ A_2 \sin(\omega_2 t + \phi_2) \end{bmatrix}, \quad \omega_1 \text{ or } \omega_2 \neq 0 \quad (5.55)$$

Adding our values for the problem at $t = 0$ this becomes:

$$\begin{bmatrix} 1 \\ 0 \end{bmatrix} = \begin{bmatrix} \frac{1}{3} & -\frac{1}{3} \\ 1 & 1 \end{bmatrix} \begin{bmatrix} A_1 \sin(\phi_1) \\ A_2 \sin(\phi_2) \end{bmatrix} \quad (5.56)$$

and after applying the dot product:

$$\begin{bmatrix} 1 \\ 0 \end{bmatrix} = \begin{bmatrix} \frac{1}{3}A_1 \sin(\phi_1) - \frac{1}{3}A_2 \sin(\phi_2) \\ A_1 \sin(\phi_1) + A_2 \sin(\phi_2) \end{bmatrix} \quad (5.57)$$

Next we can differentiate the equation for $x(t)$ to obtain the velocity solution. Adding our values for the problem at $t = 0$ obtains:

$$\begin{bmatrix} \dot{x}_1(0) \\ \dot{x}_2(0) \end{bmatrix} = \begin{bmatrix} v_{10} \\ v_{20} \end{bmatrix} = \begin{bmatrix} 0 \\ 0 \end{bmatrix} = \begin{bmatrix} \frac{\sqrt{2}}{3}A_1 \cos(\phi_1) - \frac{2}{3}A_2 \cos(\phi_2) \\ \sqrt{2}A_1 \cos(\phi_1) + 2A_2 \cos(\phi_2) \end{bmatrix} \quad (5.58)$$

Now that we have 4 equations for 4 unknowns we can use these equations to solve for A_1 , A_2 , ϕ_1 , and ϕ_2 . The 4 equations are:

$$3 = A_1 \sin(\phi_1) - A_2 \sin(\phi_2) \quad (5.59)$$

$$0 = A_1 \sin(\phi_1) + A_2 \sin(\phi_2) \quad (5.60)$$

$$0 = \sqrt{2}A_1 \cos(\phi_1) - 2A_2 \cos(\phi_2) \quad (5.61)$$

$$0 = \sqrt{2}A_1 \cos(\phi_1) + 2A_2 \cos(\phi_2) \quad (5.62)$$

Setting these last two equations equal to each other yields:

$$0 = \sqrt{2}A_1 \cos(\phi_1) + 2A_2 \cos(\phi_2) = \sqrt{2}A_1 \cos(\phi_1) - 2A_2 \cos(\phi_2) \quad (5.63)$$

or:

$$0 = -4A_2 \cos(\phi_2) \quad (5.64)$$

For this equation to be true, $\phi_2 = \frac{\pi}{2}$. Therefore, applying this to $0 = \sqrt{2}A_1 \cos(\phi_1) + 2A_2 \cos(\phi_2)$ results in:

$$0 = \sqrt{2}A_1 \cos(\phi_1) \quad (5.65)$$

where again, for this equation to be true, $\phi_1 = \frac{\pi}{2}$. Now the first two equations become:

$$3 = A_1 - A_2 \quad (5.66)$$

$$0 = A_1 + A_2 \quad (5.67)$$

Where this shows us that $A_1 = \frac{3}{2}$ and $A_2 = -\frac{3}{2}$.

Now that we have the initial conditions we can find a solution for the temporal response of each mass. Using the equations from before:

$$x_1(t) = A_1 \sin(\omega_1 t + \phi_1)u_{11} + A_2 \sin(\omega_2 t + \phi_2)u_{12} \quad (5.68)$$

$$x_2(t) = A_1 \sin(\omega_1 t + \phi_1) u_{21} + A_2 \sin(\omega_2 t + \phi_2) u_{22} \quad (5.69)$$

And applying our obtained values

$$x_1(t) = \frac{3}{2} \sin(\sqrt{2}t + \frac{\pi}{2}) \frac{1}{3} + \left(-\frac{3}{2}\right) \sin(2t + \frac{\pi}{2}) \left(-\frac{1}{3}\right) \quad (5.70)$$

$$x_2(t) = \frac{3}{2} \sin(\sqrt{2}t + \frac{\pi}{2}) + \left(-\frac{3}{2}\right) \sin(2t + \frac{\pi}{2}) \quad (5.71)$$

results in:

$$x_1(t) = \frac{1}{2} \left(\sin(\sqrt{2}t + \frac{\pi}{2}) + \sin(2t + \frac{\pi}{2}) \right) \quad (5.72)$$

$$x_2(t) = \frac{3}{2} \left(\sin(\sqrt{2}t + \frac{\pi}{2}) - \sin(2t + \frac{\pi}{2}) \right) \quad (5.73)$$

These results can be plotted as:

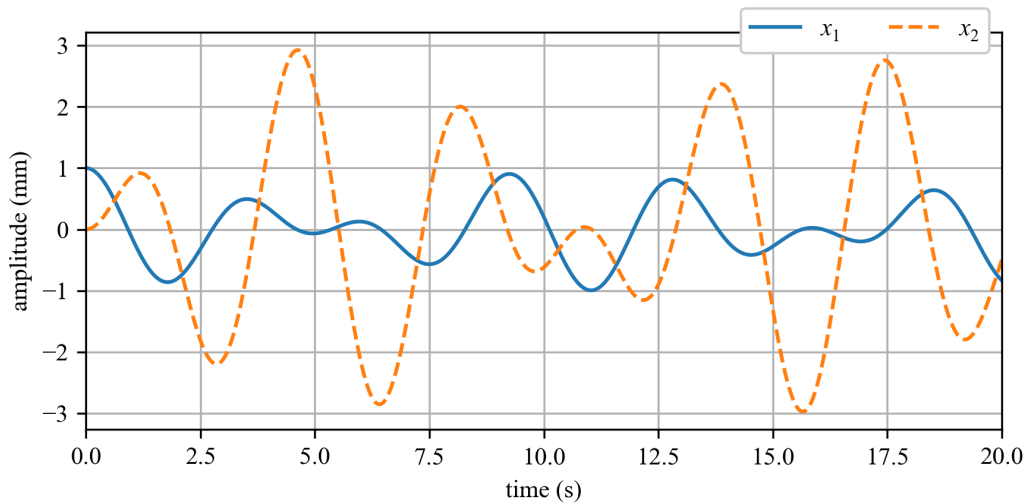

Figure 5.7: Temporal response for each of the rigid bodies in the 2-DOF system.

Example 5.2 Plotting Mode Shapes

Mode shapes can be better understood through a graphical representation. To do this, consider the 2-DOF system presented in figure 5.8(a). Assuming that $x_1 < x_2$ the FBD for the system is expressed in figure 5.8(b).

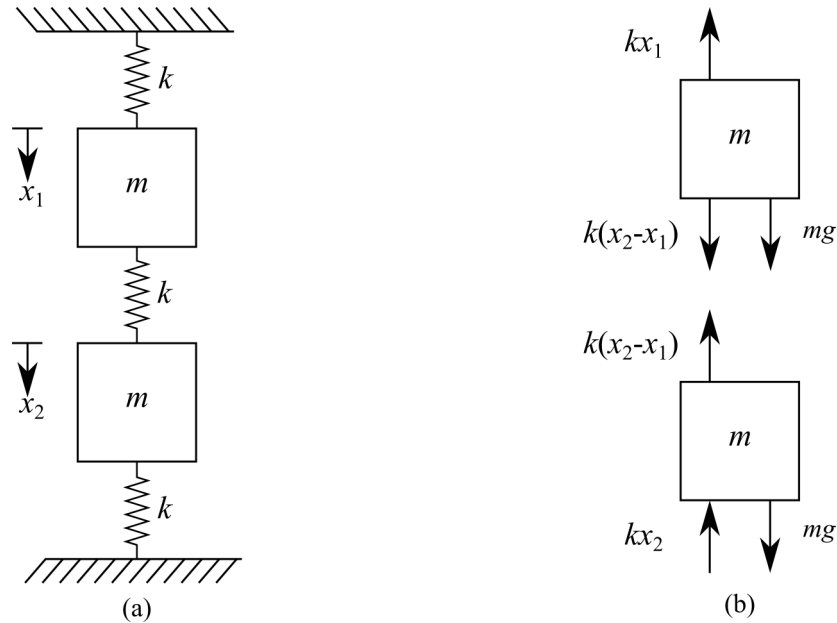

Figure 5.8: (a) 2-DOF system with two masses arranged in a vertical configuration; and (b) FBD of system.

For simplicity, all masses, and spring stiffness are considered equal and that $m = 1$ and $k = 1$.

Solution:

From the previous investigations in this text, we know that the forces caused by gravity will cancel out. Therefore, the EOM for the system can be written as:

$$\begin{aligned} m\ddot{x}_1 &= -kx_1 + k(x_2 - x_1) \\ m\ddot{x}_2 &= -k(x_2 - x_1) - kx_2 \end{aligned} \quad (5.74)$$

These equations can be written in matrix notation as:

$$\begin{bmatrix} m & 0 \\ 0 & m \end{bmatrix} \begin{bmatrix} \ddot{x}_1 \\ \ddot{x}_2 \end{bmatrix} + \begin{bmatrix} 2k & -k \\ -k & 2k \end{bmatrix} \begin{bmatrix} x_1 \\ x_2 \end{bmatrix} = \begin{bmatrix} 0 \\ 0 \end{bmatrix} \quad (5.75)$$

Substituting the values of the matrices M and K into this expression $\det(-\omega^2 M + K) = 0$ yields:

$$\det \begin{bmatrix} -\omega^2 m + 2k & -k \\ -k & -\omega^2 m + 2k \end{bmatrix} = 0 \quad (5.76)$$

The determinant yields that the unknown quantity, ω^2 , must satisfy:

$$m^2\omega^4 - 4km\omega^2 + 3k^2 = 0 \quad (5.77)$$

using the quadratic formula we obtain

$$\omega_1 = \pm\sqrt{\frac{k}{m}} = 1 \text{ rad/sec}, \quad \omega_2 = \pm\sqrt{\frac{3k}{m}} = \sqrt{3} \text{ rad/sec} \quad (5.78)$$

Now, we need to obtain solutions for \vec{u}_1 and \vec{u}_2 . Knowing $(-\omega_1^2 M + K)\vec{u}_1 = 0$ yields:

$$\begin{bmatrix} 1 & -1 \\ -1 & 1 \end{bmatrix} \begin{bmatrix} u_{11} \\ u_{21} \end{bmatrix} = \begin{bmatrix} 0 \\ 0 \end{bmatrix} \quad (5.79)$$

Taking the dot product of the matrix equation yields:

$$u_{11} - u_{21} = 0, \text{ and } -u_{12} + u_{22} = 0 \quad (5.80)$$

Setting $u_{11} = 1$ results in $u_{21} = 1$. The same processes can be performed for \vec{u}_2 to show that if we set $u_{12} = 1$, $u_{22} = -1$. Therefore, the mode shapes can be expressed as:

$$\vec{u}_1 = \begin{bmatrix} u_{11} \\ u_{21} \end{bmatrix} = \begin{bmatrix} 1 \\ 1 \end{bmatrix} \text{ and } \vec{u}_2 = \begin{bmatrix} u_{12} \\ u_{22} \end{bmatrix} = \begin{bmatrix} 1 \\ -1 \end{bmatrix} \quad (5.81)$$

The displacement of the masses as a function of time and the general mode shape plots are graphically represented in figure 5.9. In the 2-DOF system considered here, the second mode shape has a spot at the center of the middle spring that does not move (i.e. has zero displacement). This point is called a node. Nodes correspond to points in the mode shape where the displacement is always zero. Furthermore, the displacement of the node points remain zero at all times, as diagrammed in the top-right of figure 5.9.

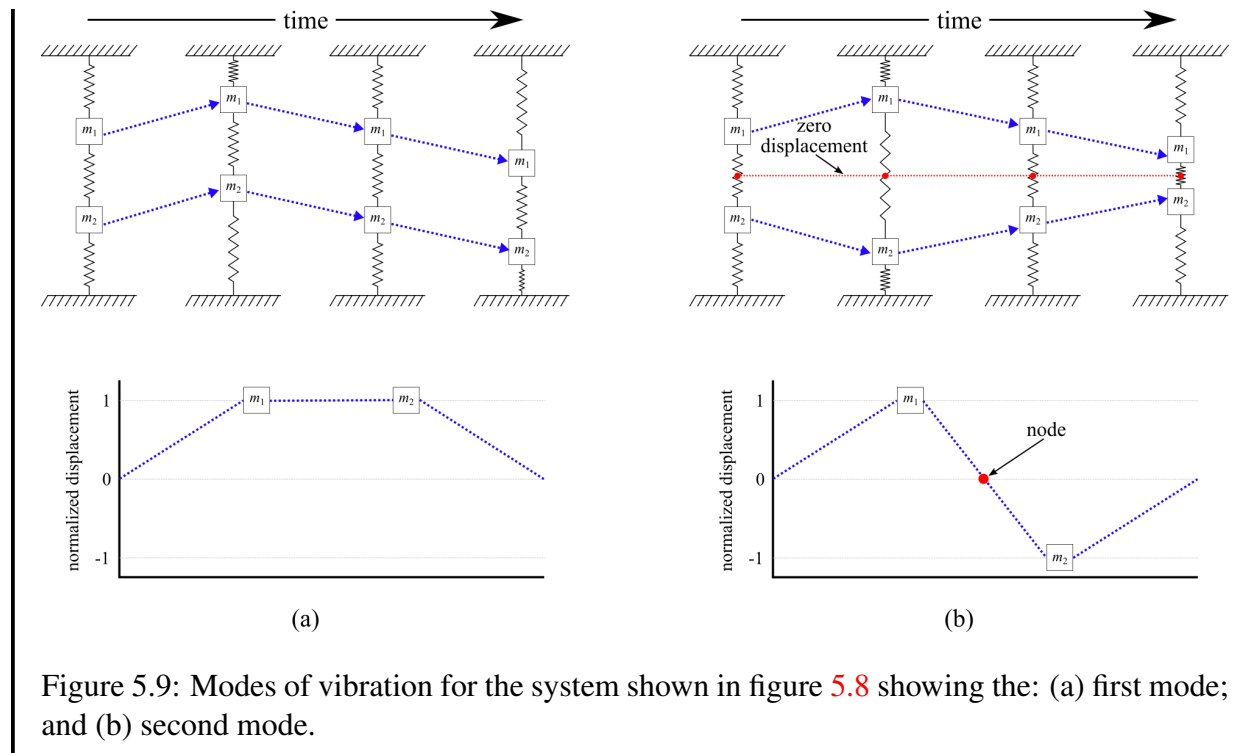

Figure 5.9: Modes of vibration for the system shown in figure 5.8 showing the: (a) first mode; and (b) second mode.

5.3 Explicit method for Solving 2-DOF Systems

As before, we can use explicit methods for solving multiple degree of freedom problems. Cramer’s rule is an explicit formula for the solution of a system of linear equations with as many equations as unknowns. Cramer’s rule is valid whenever the system has a unique solution and can be used as a more generalized approach to solving for the temporal solution to a 2-DOF. Consider the 2-DOF systems shown in figure 5.10, where x_2 displaces more than x_1 . The two coupled equations of motion are expressed as:

$$\begin{aligned} m_1\ddot{x}_1 + (c_1 + c_2)\dot{x}_1 - c_2\dot{x}_2 + (k_1 + k_2)x_1 - k_2x_2 &= 0 \\ m_2\ddot{x}_2 + (c_2 + c_3)\dot{x}_2 - c_2\dot{x}_1 + (k_2 + k_3)x_2 - k_2x_1 &= 0 \end{aligned} \tag{5.82}$$

As before, taking the Laplace of the EOM (while ignoring the initial conditions) changes the equation from the temporal domain to the complex s -plane. This yields:

$$\begin{aligned} m_1s^2X_1(s) + (c_1 + c_2)sX_1(s) - c_2sX_2(s) + (k_1 + k_2)X_1(s) - k_2X_2(s) &= F_1(s) \\ m_2s^2X_2(s) + (c_2 + c_3)sX_2(s) - c_2sX_1(s) + (k_2 + k_3)X_2(s) - k_2X_1(s) &= F_2(s) \end{aligned} \tag{5.83}$$

these equations can be rearranged in terms of X_1 and X_2 as follows:

$$\begin{aligned} [m_1s^2 + (c_1 + c_2)s + (k_1 + k_2)]X_1(s) - [c_2s + k_2]X_2(s) &= F_1(s) \\ [m_2s^2 + (c_2 + c_3)s + (k_2 + k_3)]X_2(s) - [c_2s + k_2]X_1(s) &= F_2(s) \end{aligned} \tag{5.84}$$

These equations show two linear equations in terms of X_1 and X_2 that can be solved for using Cramer’s rule, resulting in the expression:

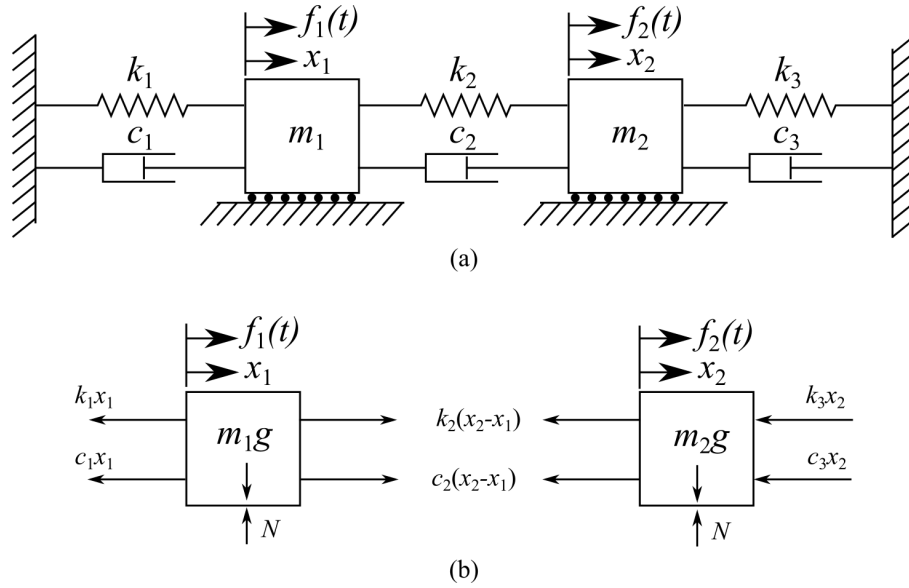

Figure 5.10: Forced 2-DOF damped system showing: (a) system, and; (b) FBD.

$$X_1(s) = \frac{D_1(s)}{D(s)} \quad (5.85)$$

$$X_2(s) = \frac{D_2(s)}{D(s)}$$

where:

$$D_1 = \begin{vmatrix} F_1(s) & -(c_2s + k_2) \\ F_2(s) & m_2s^2 + (c_2 + c_3)s + (k_2 + k_3) \end{vmatrix} \quad (5.86)$$

$$= [m_2s^2X_2(s) + (c_2 + c_3)s + (k_2 + k_3)]F_1(s) + (c_2s + k_2)F_2(s)$$

$$D_2 = \begin{vmatrix} m_1s^2 + (c_1 + c_2)s + (k_1 + k_2) & F_1(s) \\ -(c_2s + k_2) & F_2(s) \end{vmatrix} \quad (5.87)$$

$$= [m_1s^2 + (c_1 + c_2)s + (k_1 + k_2)]F_2(s) + (c_2s + k_2)F_1(s)$$

$$D = \begin{vmatrix} m_1s^2 + (c_1 + c_2)s + (k_1 + k_2) & m_2s^2 + (c_2 + c_3)s + (k_2 + k_3) \\ -(c_2s + k_2) & -(c_2s + k_2) \end{vmatrix} \quad (5.88)$$

$$= m_1m_2s^4 + [m_2(c_1 + c_3) + m_1(c_2 + c_3)]s^3$$

$$+ [m_2(k_1 + k_2) + m_1(k_2 + k_3) + c_1c_2 + c_2c_3 + c_3c_1]s^2$$

$$+ [(k_1 + k_2)(c_2 + c_3) + c_1k_2 + c_1k_3 - c_2k_2 + c_2k_3]s$$

$$+ (k_1k_2 + k_2k_3 + k_3k_1)$$

The denominator, $D(s)$ is a 4th polynomial in s and is the characteristic polynomial of the system. The system is considered a 4th order system because the characteristic polynomial of the system is of order 4.

Vibration Case Study 5.2 Closely Coupled Modes in Complex Structures

Multi-span concrete bridges like the Trigno V bridge (figure 5.11) over the Trigno river in Italy have repeating segments that make up the bridge decks. The structural components of the segmented bridge decks are separate components sitting on bearing pads and piers where the only connecting material between decks is the overlay that is added to provide a contentious road surface. This configuration forms what is known as a partially-connected bridge deck^a.



Figure 5.11: The Trigno V bridge over the Trigno river that carries SS650 north of Trivento Italy is made up of seven repeating concrete bridge deck^b.

This system can be modeled as a multi-degree of freedom problem. However, the challenge is that with so many nearly identical bridge components, the natural frequencies of each bridge deck will be close, but not identical. This results in a clustering of natural frequencies as shown in figure 5.12 where the frequencies of the 1st and 2nd modes of the various bridge deck components are clustered in groups and therefore hard to distinguish. Moreover, obtaining the characteristic structural dynamics of any particular bridge deck section would be difficult as the decks are coupled through the pavement overlay making it challenging to isolate the dynamic measurements of just one bridge section.

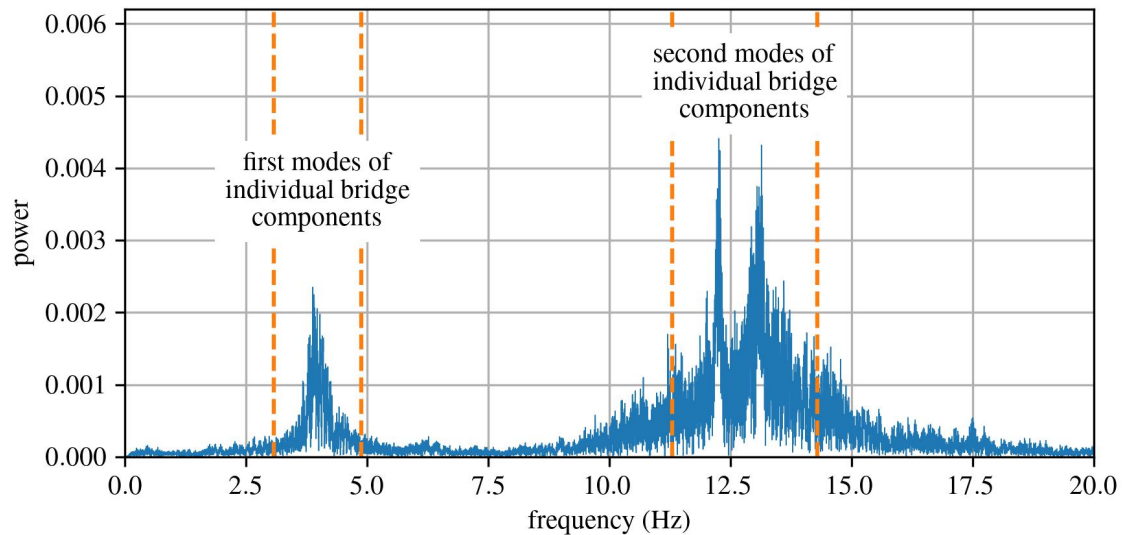

Figure 5.12: Measured acceleration signal for the bridge showing the estimated 1st and 2nd frequencies for the obtained using the method outlined in Tomassini et al.^a.

^aTomassini E., Garc a-Mac as E., Reynders E., Ubertini F., Modal analysis for damage identification of partially continuous multi-span bridges, Journal of Physics: Conference Series, Eurodyn 2023: XII International Conference on Structural Dynamics (2023).

^bImagery 2003 Google and Maxar Technologies used in accordance with their general guidelines on sharing (2003) and likely falls under free use in the U.S.

5.4 Eigenvalue-based Solution for Natural Frequencies and Mode Shapes

The process of calculating the mode shapes presented in section 5.2 is long and tedious. Therefore, methods that can be easily deployed on computers are of great interest to the practitioner. An eigenvalue-based solution that takes advantage of the symmetry in the M and K matrices and can be easily implemented on a computer is discussed in this section.

Review 5.2 Eigenvalues and Eigenvectors

In linear algebra, eigenvalues (λ) and eigenvectors (\vec{v}) are concepts that appear prominently in the analysis of linear transformations. By definition, if \vec{v} is a vector (in vector space V over a field F) and T is a linear transformation into itself, then \vec{v} is an eigenvector of T if $T(\vec{v})$ is a scalar multiple of \vec{v} :

$$T(\vec{v}) = \lambda \vec{v} \quad (5.89)$$

where λ is a scalar in the field F , known as the eigenvalue associated with the eigenvector \vec{v} . If the linear transformation is expressed in the form of an $n \times n$ matrix \mathbf{A} , then the eigenvalue equation for a linear transformation above can be rewritten as the matrix multiplication

$$\mathbf{A}\mathbf{v} = \lambda \mathbf{v} \quad (5.90)$$

where \mathbf{v} is a $n \times 1$ matrix of the eigenvectors and λ is a square matrix with eigenvalues on

the diagonal such that:

$$\lambda = \begin{bmatrix} \lambda_1 & 0 \\ 0 & \lambda_2 \end{bmatrix} \quad (5.91)$$

and if needed a row-wise vector of the diagonal can be formed $\vec{\lambda} = [\lambda_1, \lambda_2]^T$. For the matrix A , eigenvalues and eigenvectors can be used to decompose the matrix.

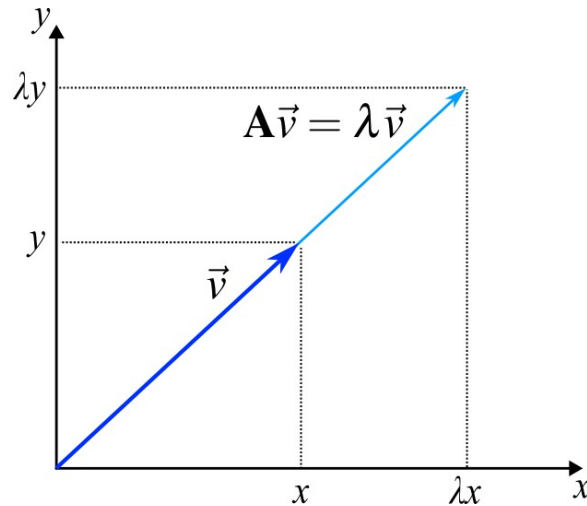

Figure 5.13: Matrix A acts by stretching the vector \vec{v} , not changing its direction, so \vec{v} is an eigenvector of A .

The generalized eigenvalue problem is an important formulation for the study of vibrations and is written as

$$A\mathbf{v} = \vec{\lambda}B\mathbf{v} \quad (5.92)$$

where A and B are real matrices. As written, this expression maps a general space A into B using $\vec{\lambda}$ and \mathbf{v} . In the study of vibrations, the general generalized eigenvalue problem is used to link mass (M) and stiffness (k) matrices such that

$$K\mathbf{v} = \vec{\lambda}M\mathbf{v} \quad (5.93)$$

5.4.1 Deriving the Eigenvalue-based Solution

To derive an eigenvalue-based solution for calculating the natural frequencies and mode shapes in a computationally efficient way, we need to merge our mass and stiffness into one expression; termed the mass normalized stiffness \tilde{K} matrix that we mathematically define later. First, let us consider that the vast majority of mass (M) and stiffness (K) matrices are symmetric and positive definite due to the physical meaning of these matrices. Therefore, M can be factored into two terms using the Cholesky decomposition:

$$M = LL^T \quad (5.94)$$

Review 5.3 Cholesky Decomposition

The Cholesky decomposition of a real positive-definite matrix A is a decomposition of the form:

$$\mathbf{A} = \mathbf{L}\mathbf{L}^T \quad (5.95)$$

where \mathbf{L} is the lower triangular matrix of \mathbf{A} . A matrix is positive definite if the scalar $\mathbf{x}^T \mathbf{A} \mathbf{x}$ is positive for any non-zero vector x comprised of real numbers:

$$\mathbf{x}^T \mathbf{A} \mathbf{x} > 0 \quad (5.96)$$

For the unique case diagonal mass matrices (all the mass values lie along the diagonal of the matrix) the Cholesky decomposition (L) is defined as:

$$L = M^{1/2} = \begin{bmatrix} \sqrt{m_1} & 0 \\ 0 & \sqrt{m_2} \end{bmatrix} \quad (5.97)$$

While a special case that is not always true, it is a commonly encountered mass matrix formulation due to the nature of mass matrices. Moreover, the example considered within this test all consists of a diagonal mass matrix. For the special case diagonal mass matrices, equation 5.97 factors into:

$$M = M^{1/2} M^{1/2} \quad (5.98)$$

Moreover, the inverse of the diagonal matrix ($M^{1/2}$) is denoted as $M^{-1/2}$ and defined as:

$$L^{-1} = M^{-1/2} = \begin{bmatrix} \frac{1}{\sqrt{m_1}} & 0 \\ 0 & \frac{1}{\sqrt{m_2}} \end{bmatrix} \quad (5.99)$$

Now, let us consider the previously derived EOM for an undamped 2-DOF system:

$$M\ddot{\vec{x}} + K\vec{x} = 0 \quad (5.100)$$

This expression can be transformed into a symmetric eigenvalue problem, allowing us to leverage the strengths of symmetric eigenvalue mathematics and computer solvers. To solve the perform this transform, we set $\vec{x} = M^{-1/2}\vec{q}$ and multiply the equation by $M^{-1/2}$ such that the EOM becomes:

$$M^{-1/2} M M^{-1/2} \ddot{\vec{q}} + M^{-1/2} K M^{-1/2} \vec{q} = 0 \quad (5.101)$$

As $M^{-1/2} M M^{-1/2}$ is equal to the identity matrix I and defining $M^{-1/2} K M^{-1/2}$ as the mass normalized stiffness \tilde{K} yields the simplified expression:

$$I\ddot{\vec{q}} + \tilde{K}\vec{q} = 0 \quad (5.102)$$

where $\tilde{K} = M^{-1/2} K M^{-1/2}$ is equivalent to the expression k/m from the 1-DOF system as the are both mass-normalized stiffness values.

As before, a solution is found by assuming a solution, taking the derivatives of the solution, and substituting it into the EOM. Following these steps and assuming a solution of:

$$\vec{q} = \mathbf{v}e^{j\omega t} \quad (5.103)$$

where \mathbf{v} is an $n \times n$ matrix for a system with n degrees of freedom. Adding this assumed solution to the EOM results in the form:

$$-\mathbf{v}\omega^2 e^{j\omega t} + \tilde{\mathbf{K}}\mathbf{v}e^{j\omega t} = 0 \quad (5.104)$$

driving out the nonzero scalar $e^{j\omega t}$ and rearranging the above expression results in:

$$\tilde{\mathbf{K}}\mathbf{v} = \omega^2\mathbf{v} \quad (5.105)$$

Knowing that $\mathbf{v} \neq 0$, as a matrix of zeros would mean no motion is present in the system, this equation can be expressed in a typical eigenvalue formulation:

$$\tilde{\mathbf{K}}\mathbf{v} = \lambda\mathbf{v} \quad (5.106)$$

where \mathbf{v} is a column matrix made up of the eigenvectors ($\mathbf{v} = [v_1, v_1, \dots, v_n]$) and λ is a square matrix with eigenvalues on the diagonal. As $\tilde{\mathbf{K}}$ is symmetric, this is a symmetric eigenvalue problem.

An important attribute of eigenvectors to note is that the eigenvectors only encode information about the direction of the transformation while information on the magnitude is captured by the eigenvalue. Therefore, different values within an eigenvector may be used to represent the same direction. A challenge for the entry-level practitioner is that different software systems may return different eigenvectors for the same problem. For example, MATLAB^a returns eigenvectors such that the 2-norm of each is 1. However, when solved symbolically^b non-normalized eigenvectors are returned. Various other engineering-focused applications may return normalized or non-normalized eigenvectors^c. Therefore, it is helpful for practitioners to normalize computed eigenvectors to unit norm eigenvectors to allow for comparison between different computational tools.

Review 5.4 Vector Norms

The Euclidean norm of a vector (also termed as 2-norm, Euclidean length or the vector magnitude) is defined as:

$$\|\mathbf{v}\| = \sqrt{\sum_{i=1}^n (v_i^2)} = \sqrt{\mathbf{v}^T\mathbf{v}} \quad (5.107)$$

If $\|\mathbf{v}\| = 1$ it is a “unit norm”. If $\|\mathbf{v}\|$ is not a unit norm vector, it can be converted to one by applying a scalar α such that $\alpha\mathbf{v} = 1$. In general, a nonzero vector \mathbf{v} of any

^aMATLAB 2023a eig function.

^bMATLAB 2023a Symbolic Math Toolbox.

^cLAPACK.

length can be normalized to $\mathbf{v}_{\text{normalized}}$ using the following expression:

$$\mathbf{v}_{\text{normalized}} = \frac{1}{\sqrt{\mathbf{v}^T \mathbf{v}}} \mathbf{v} \quad (5.108)$$

Example 5.3 Normalizing Vectors

Normalize the Eigenvector $\vec{v}_1 = [1/3 \ 1]^T$.

Solution:

First, let's check the Euclidean norm of \vec{v}_1 , this is $\sqrt{1^2 + 1/3^2} = \sqrt{1.11} = 1.05$; therefore, the unit vector is not unit norm.

To normalize the vector \vec{v}_1 , a scalar (α) is calculated to make $\alpha \mathbf{v} = 1$. Therefore, following the definition of an orthogonal vector:

$$(\alpha \vec{v}_1)^T (\alpha \vec{v}_1) = 1 \quad (5.109)$$

or:

$$\alpha [1/3 \ 1] \alpha \begin{bmatrix} 1 \\ 3 \\ 1 \end{bmatrix} = \alpha^2 (1/9 + 1) = 1 \quad (5.110)$$

Therefore, $\alpha = 3/\sqrt{10}$. Resulting in a normalized unit vector of

$$\vec{v}_{1\text{-normalized}} = \alpha \vec{v}_1 = \begin{bmatrix} \frac{1}{\sqrt{10}} \\ \frac{3}{\sqrt{10}} \\ \frac{1}{\sqrt{10}} \end{bmatrix} \quad (5.111)$$

as $\sqrt{(1/\sqrt{10})^2 + (3/\sqrt{10})^2} = 1$

Eigenvalues from the EOM are equal to ω^2 . Or more importantly, $\omega_i = \sqrt{\lambda_i}$. Moreover, we can relate the eigenvectors to the modes shapes by a factor of the mass matrix:

$$\vec{u}_1 = M^{-1/2} \vec{v}_1 \quad (5.112)$$

The important thing to remember is that the natural frequencies are the square root of the eigenvalues and the mode shapes are related to the eigenvectors through the mass matrix. Expanding on equation 5.112, one can go from the mode shapes to the eigenvector through:

$$\vec{v}_1 = M^{1/2} \vec{u}_1 \quad (5.113)$$

therefore, it can be seen that the eigenvectors and mode shapes are related through the mass normalization process.

Example 5.4 Calculating Eigenvalue-based Solutions for System Dynamics

Consider the system presented in example 5.1 and repeated below where $m_1=9$ kg, $m_2=1$ kg, $k_1 = 24$ N/m, and $k_2 = 3$ N/m with the initial conditions $x_{10} = 1$ mm, $v_{10} = 0$ mm/s, $x_{20} = 0$ mm, and $v_{20} = 0$ mm/s. Calculate the natural frequencies and the mode shapes using the eigenvalue solution.

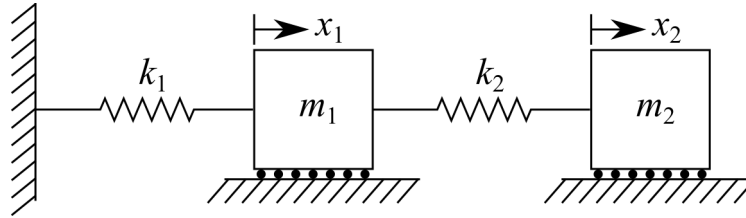

Figure 5.14: 2-DOF system with two masses and two independent confidante systems x_1 and x_2 .

Solution:

Writing the mass and stiffness matrix of the system as:

$$M = \begin{bmatrix} 9 & 0 \\ 0 & 1 \end{bmatrix} \quad (5.114)$$

and

$$K = \begin{bmatrix} 27 & -3 \\ -3 & 3 \end{bmatrix} \quad (5.115)$$

we can compute \tilde{K} using the following expression:

$$\tilde{K} = M^{-1/2}KM^{-1/2} \quad (5.116)$$

where $KM^{-1/2}$ is computed first to maintain symmetry. This results in:

$$KM^{-1/2} = \begin{bmatrix} 27 & -3 \\ -3 & 3 \end{bmatrix} \begin{bmatrix} \frac{1}{3} & 0 \\ 0 & 1 \end{bmatrix} = \begin{bmatrix} 9 & -3 \\ -1 & 3 \end{bmatrix} \quad (5.117)$$

and:

$$\tilde{K} = M^{-1/2}KM^{-1/2} = \begin{bmatrix} \frac{1}{3} & 0 \\ 0 & 1 \end{bmatrix} \begin{bmatrix} 9 & -3 \\ -1 & 3 \end{bmatrix} = \begin{bmatrix} 3 & -1 \\ -1 & 3 \end{bmatrix} \quad (5.118)$$

Now a solution must be obtained for the eigenvalue problem:

$$\tilde{K}\mathbf{v} = \lambda\mathbf{v} \quad (5.119)$$

While this can be obtained using computers for such a simple case it is more appropriate to solve this expression by hand. Therefore, the above expression can be rewritten as:

$$(\tilde{K} - \lambda I)\mathbf{v} = 0 \quad (5.120)$$

However, as $\mathbf{v} \neq 0$ the matrix must be singular, the determinant of the $(\tilde{K} - \lambda I)$ matrix must equal zero. Or:

$$\det \begin{bmatrix} 3 - \lambda & -1 \\ -1 & 3 - \lambda \end{bmatrix} = 0 \quad (5.121)$$

This can be expanded to the characteristic equation:

$$\lambda^2 - 6\lambda + 8 = 0 \quad (5.122)$$

with the roots (eigenvalues):

$$\lambda_1 = 2 \text{ and } \lambda_2 = 4 \quad (5.123)$$

Therefore, $\omega_1 = \sqrt{2}$ and $\omega_2 = 2$. These are the same values computed in example 5.1. The eigenvectors for λ_1 are computed as:

$$(\tilde{K} - \lambda_1 I)\mathbf{v} = 0 \quad (5.124)$$

or:

$$\begin{bmatrix} 3 - 2 & -1 \\ -1 & 3 - 2 \end{bmatrix} \begin{bmatrix} v_{11} \\ v_{21} \end{bmatrix} = \begin{bmatrix} 0 \\ 0 \end{bmatrix} \quad (5.125)$$

This results in two dependent scalar equations:

$$v_{11} - v_{21} = 0 \text{ and } -v_{11} + v_{21} = 0 \quad (5.126)$$

That show us that $v_{11} = v_{21}$ or $\vec{v}_1 = [1 \ 1]^T$. First we find that \vec{v}_1 is not a unit norm vector as $\sqrt{v_{21}^2 + v_{21}^2} \neq 1$. Therefore, let's apply a scalar α to normalize it to a unit vector. Using $(\alpha\vec{v}_1)^T(\alpha\vec{v}_1) = 1$ we obtain:

$$\alpha[1 \ 1]\alpha \begin{bmatrix} 1 \\ 1 \end{bmatrix} = \alpha^2(2) = 1 \quad (5.127)$$

or $\alpha = 1/\sqrt{2}$. This allows us to normalize the vector knowing $\alpha\vec{v}_1 = 1$, resulting in a normalized vector of:

$$\alpha\vec{v}_1 = \frac{1}{\sqrt{2}} \begin{bmatrix} 1 \\ 1 \end{bmatrix} = \begin{bmatrix} 0.71 \\ 0.71 \end{bmatrix} \quad (5.128)$$

A similar process is followed for $\lambda_2 = 4$ that leads to the normalized vector

$$\alpha\vec{v}_2 = \frac{1}{\sqrt{2}} \begin{bmatrix} -1 \\ 1 \end{bmatrix} = \begin{bmatrix} -0.71 \\ 0.71 \end{bmatrix} \quad (5.129)$$

Lastly, the normalized eigenvectors can be converted to mode shapes using $\mathbf{u} = M^{-1/2}\mathbf{v}$. Resulting in:

$$\vec{u}_1 = \begin{bmatrix} \frac{1}{3} & 0 \\ 0 & 1 \end{bmatrix} \begin{bmatrix} 0.71 \\ 0.71 \end{bmatrix} = \begin{bmatrix} 0.24 \\ 0.71 \end{bmatrix} \quad (5.130)$$

and:

$$\vec{u}_2 = \begin{bmatrix} \frac{1}{3} & 0 \\ 0 & 1 \end{bmatrix} \begin{bmatrix} -0.71 \\ 0.71 \end{bmatrix} = \begin{bmatrix} -0.24 \\ 0.71 \end{bmatrix} \quad (5.131)$$

While these mode shapes are correct, it is common practice to report them normalized with a maximum value of 1, therefore, $\vec{u}_1 = [1/3 \ 1]$ and $\vec{u}_2 = [-1/3 \ 1]$. While unit-normalization of the eigenvectors was not required in this example to obtain the right solution, it is good practice. Note that these are the same mode shape vectors as computed in example 5.1.

Example 5.5 Eigenvalue Approach Solved using MATLAB

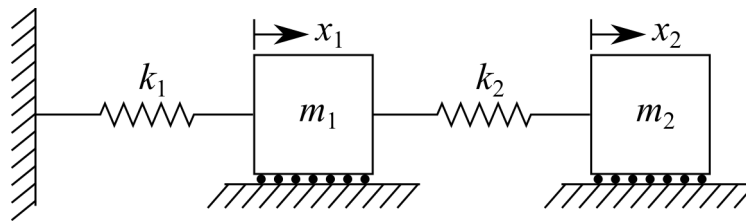

Figure 5.15: 2-DOF system with two masses and two independent confidante systems x_1 and x_2 .

Using the Eigenvalue approach and MATLAB, determine the natural frequencies and mode shapes of the system shown in figure 5.15, where $m_1=9$ kg, $m_2=1$ kg, $k_1 = 24$ N/m, and $k_2 = 3$ N/m with the initial conditions $x_{10} = 1$ mm, $v_{10} = 0$ mm/s, $x_{20} = 0$ mm, and $v_{20} = 0$ mm/s with the EOM expressed as:

$$\begin{bmatrix} m_1 & 0 \\ 0 & m_2 \end{bmatrix} \begin{bmatrix} \ddot{x}_1 \\ \ddot{x}_2 \end{bmatrix} + \begin{bmatrix} k_1 + k_2 & -k_2 \\ -k_2 & k_2 \end{bmatrix} \begin{bmatrix} x_1 \\ x_2 \end{bmatrix} = \begin{bmatrix} 0 \\ 0 \end{bmatrix} \quad (5.132)$$

Solution:

Using the eigenvalue method, the following MATLAB code will solve for the natural frequencies and mode shapes:

Listing 3: MATLAB code to find the frequencies and mode shapes of a 2-DOF system.

```
% define the M and K matrix
M = [9 0; 0 1]
K = [24+3 -3; -3 3]

% build the M inverse square-root and mass normalized stiffness matrix
M_inv_sqr = sqrt(inv(M))
K_mass_norm = M_inv_sqr*K*M_inv_sqr

% Using, K_mass_norm*v=lambda*v
[v,lambda] = eig(K_mass_norm)
```

```

% Solve for natural frequencies
omega_1 = sqrt(lambda(1,1))
omega_2 = sqrt(lambda(2,2))

% solve for the mode shapes
u_1 = M_inv_sqr*v(:,1)
u_2 = M_inv_sqr*v(:,2)

```

where $\omega_1=1.41$ rad/sec and $\omega_2=2$ rad/sec while $\vec{u}_1 = [0.333 \ 1]$ and $\vec{u}_2 = [-0.333 \ 1]$.

5.5 Transfer-function Method

As in 1-DOF systems, transfer functions can be used to solve for the temporal response of 2-DOF systems under a variety of inputs. Again, the transfer function of a differential equation is defined as the ratio of the Laplace transform of the output (system response) to the Laplace transform of the input (forcing function). Moreover, the procedure for using the Laplace transform to solve the equations of motion is the same and follows three steps:

1. Take the Laplace transform of both sides of the EOM while treating the time derivatives symbolically.
2. Solve for $X(s)$ in the obtained equation.
3. Apply the inverse transform $x(t) = \mathcal{L}[X(s)]^{-1}$.

Example 5.6 2-DOF System Subjected to Impulse

Two masses are connected through a spring, as shown in figure 5.16.

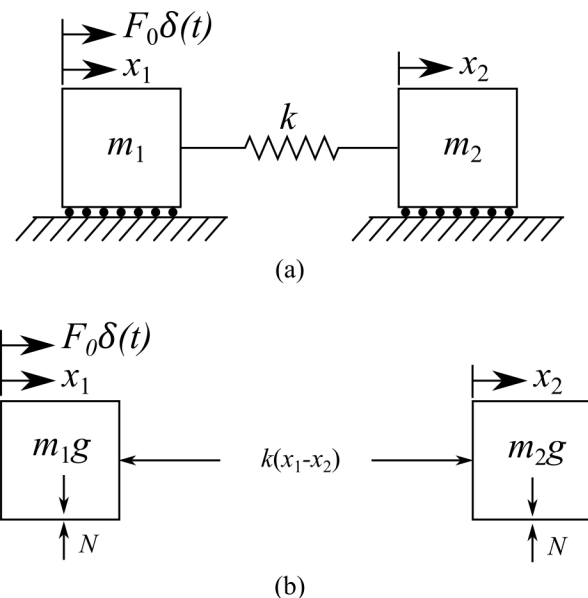

Figure 5.16: 2-DOF system subjected to an impulse showing: (a) system, and (b) FBD.

Solution:

Assuming that x_1 displaces more than x_2 , the equations of motion are:

$$\begin{aligned} m_1\ddot{x}_1 + k(x_1 - x_2) &= F_0\delta(t) \\ m_2\ddot{x}_2 + k(x_2 - x_1) &= 0 \end{aligned} \quad (5.133)$$

Taking the Laplace of both equations (step 1) yields:

$$\begin{aligned} (m_1s^2 + k)X_1(s) - kX_2(s) &= F_0 \\ -kX_1(s) + (m_2s^2 + k)X_2(s) &= 0 \end{aligned} \quad (5.134)$$

solving these two equations for X_1 and X_2 (step 2) results in:

$$\begin{aligned} X_1(s) &= \frac{F_0(m_2s^2 + k)}{s^2[m_1m_2s^2 + k(m_1 + m_2)]} \\ X_2(s) &= \frac{F_0k}{s^2[m_1m_2s^2 + k(m_1 + m_2)]} \end{aligned} \quad (5.135)$$

Using partial fractions, or a symbolic toolbox in MATLAB or Python, these expressions can be rewritten as:

$$\begin{aligned} X_1(s) &= \frac{F_0}{m_1 + m_2} \left(\frac{1}{s^2} + \frac{m_2}{\omega m_1} \frac{\omega}{s^2 + \omega^2} \right) \\ X_2(s) &= \frac{F_0}{m_1 + m_2} \left(\frac{1}{s^2} + \frac{1}{\omega} \frac{\omega}{s^2 + \omega^2} \right) \end{aligned} \quad (5.136)$$

where:

$$\omega^2 = k \left(\frac{1}{m_1} + \frac{1}{m_2} \right) \quad (5.137)$$

Taking the inverse transform of the expressions for $X_1(s)$ and $X_2(s)$ (step 3) results in expressions in the time domain and yields:

$$\begin{aligned} x_1(t) &= \frac{F_0}{m_1 + m_2} \left(t + \frac{m_2}{\omega m_1} \sin(\omega t) \right) \\ x_2(t) &= \frac{F_0}{m_1 + m_2} \left(t + \frac{1}{\omega} \sin(\omega t) \right) \end{aligned} \quad (5.138)$$

Considering a system where $F_0 = 10$ N, $m_1 = 1000$ kg, $m_2 = 1000$ kg, and $k = 1500$ N/m the temporal response is annotated in figure 5.17.

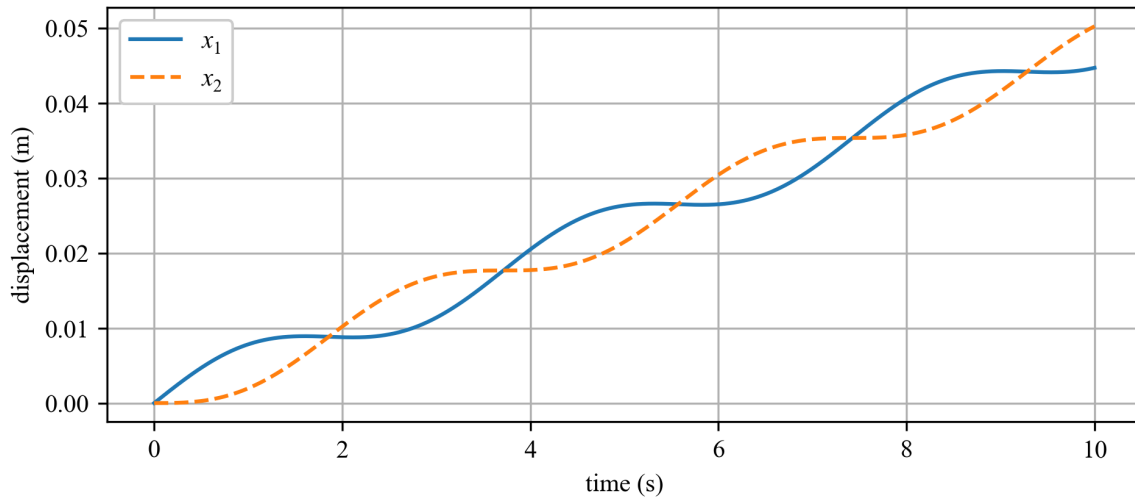

Figure 5.17: Temporal response for the considered 2-DOF system subjected to an impact load.

5.6 Multiple Degrees of Freedom

This chapter introduces methodologies for the solving of systems with more than 2-DOF. As shown in Chapter 5, 2-DOF systems can be solved analytically using 2 EOM coupled through their mode shapes. However, these methods become tedious when extended to systems with damping or even beyond the 2-DOF system.

Example 5.7 Multiple Mode Shapes

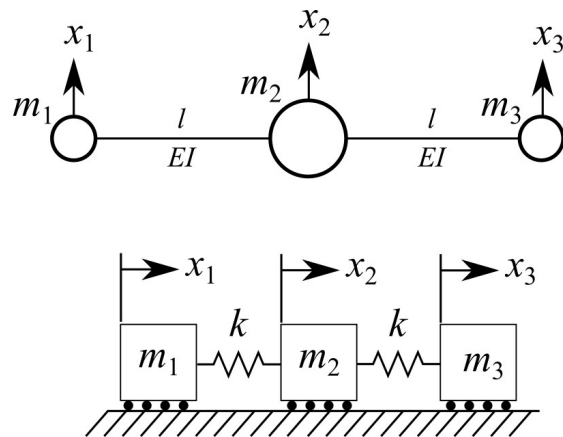

Figure 5.18: A Beechcraft Baron in flight^a along with the Free-Free 3-DOF model simplified as a mass-spring model.

Modeling the vibrations of a twin-engine airplane as a three-degree-of-freedom system can be done as shown in figure 5.18 where the fuselage is a center mass, and the engines are point masses suspended by cantilevers from the center mass. The stiffness of the wing corresponds

to the modulus of the wing E and its moment of inertia I . Assuming that $m_1 = m_3 = 1m$, $m_2 = 3m$, and $k = \frac{3EI}{l}$, the EOM can be written as:

$$m \begin{bmatrix} 1 & 0 & 0 \\ 0 & 3 & 0 \\ 0 & 0 & 1 \end{bmatrix} \begin{bmatrix} \ddot{x}_1 \\ \ddot{x}_2 \\ \ddot{x}_3 \end{bmatrix} + \frac{EI}{l} \begin{bmatrix} 3 & -3 & 0 \\ -3 & 6 & -3 \\ 0 & -3 & 3 \end{bmatrix} \begin{bmatrix} x_1 \\ x_2 \\ x_3 \end{bmatrix} = \begin{bmatrix} 0 \\ 0 \\ 0 \end{bmatrix} \quad (5.139)$$

calculate the natural frequencies and mode shapes of the system and plot the mode shapes in relation to the considered Beechcraft Baron.

Solution using the mass normalized stiffness matrix \tilde{K} :

Solving for the modes shapes using the mass normalized stiffness matrix \tilde{K} requires solving for $M^{-1/2}$ and \tilde{K} such that:

$$M^{-1/2} = \begin{bmatrix} 1 & 0 & 0 \\ 0 & 0.577 & 0 \\ 0 & 0 & 1 \end{bmatrix} \quad (5.140)$$

$$\tilde{K} = M^{-1/2}KM^{-1/2} = \frac{3EI}{l} \begin{bmatrix} 3 & -1.732 & 0 \\ -1.732 & 2 & -1.732 \\ 0 & -1.732 & 3 \end{bmatrix} \quad (5.141)$$

Then, the eigenvalue problem, formulated as:

$$\tilde{K}\mathbf{v} = \lambda\mathbf{v} \quad (5.142)$$

is solved for the eigenvalues and normalized eigenvectors using a computer, resulting in:

$$\lambda_1 = 0, \quad \lambda_2 = 1.73, \quad \lambda_3 = 2.23 \quad (5.143)$$

$$\vec{v}_1 = \begin{bmatrix} 0.447 \\ 0.775 \\ 0.447 \end{bmatrix}, \quad \vec{v}_2 = \begin{bmatrix} -0.707 \\ 0.0 \\ 0.707 \end{bmatrix}, \quad \vec{v}_3 = \begin{bmatrix} 0.548 \\ -0.632 \\ 0.548 \end{bmatrix} \quad (5.144)$$

When the eigenvalue problem is solved using the mass normalized stiffness matrix \tilde{K} the natural frequencies are $\omega_i = \sqrt{\lambda_i}$ while the mode shapes are derived from the eigenvectors as $\vec{u} = M^{-1/2}\vec{v}$. This results in:

$$\omega_1 = 0 \text{ rad/sec}, \quad \omega_2 = 1.414 \text{ rad/sec}, \quad \omega_3 = 1.826 \text{ rad/sec} \quad (5.145)$$

$$\vec{u}_1 = \begin{bmatrix} 0.447 \\ 0.447 \\ 0.447 \end{bmatrix}, \quad \vec{u}_2 = \begin{bmatrix} -0.707 \\ 0.0 \\ 0.707 \end{bmatrix}, \quad \vec{u}_3 = \begin{bmatrix} 0.548 \\ -0.365 \\ 0.548 \end{bmatrix} \quad (5.146)$$

Next, normalizing the mode shapes by the max of the vector results in:

$$\vec{u}_1 = \begin{bmatrix} 1 \\ 1 \\ 1 \end{bmatrix}, \quad \vec{u}_2 = \begin{bmatrix} -1 \\ 0 \\ 1 \end{bmatrix}, \quad \vec{u}_3 = \begin{bmatrix} 1 \\ -0.667 \\ 1 \end{bmatrix} \quad (5.147)$$

these mode shapes can then be plotted as:

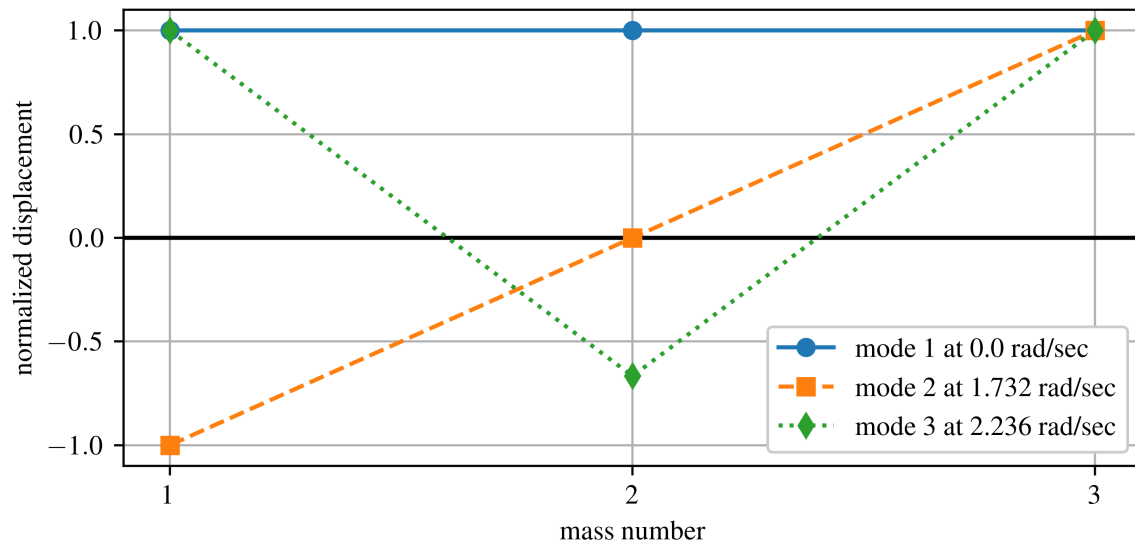

Figure 5.19: The unit vector normalized displacement of the mode shapes solved for using the mass normalized stiffness matrix \tilde{K} .

Solution using the generalized eigenvalue approach:

The mode shapes can also be solved for using the generalized eigenvalue approach where the eigenvalue problem is written as:

$$\mathbf{K}\mathbf{v} = \tilde{\lambda}\mathbf{M}\mathbf{v} \quad (5.148)$$

solving for the eigenvalues and eigenvectors yields:

$$\lambda_1 = 0, \lambda_2 = 1.73, \lambda_3 = 2.23 \quad (5.149)$$

$$v_1 = \begin{bmatrix} -0.577 \\ -0.577 \\ -0.577 \end{bmatrix}, v_2 = \begin{bmatrix} 0.707 \\ 0.0 \\ -0.707 \end{bmatrix}, v_3 = \begin{bmatrix} 0.639 \\ -0.426 \\ 0.639 \end{bmatrix} \quad (5.150)$$

Note that the eigenvalues are the same as those solved for using the normalized stiffness matrix approach while the eigenvectors appear to be different (mode 2). software tools and computing languages do not all follow the same standards in terms of returning eigenvectors as the information stored in the eigenvectors is just the direction of the transform. However, mode 2 reported here is still correct as only the shape of the eigenvalue matters.

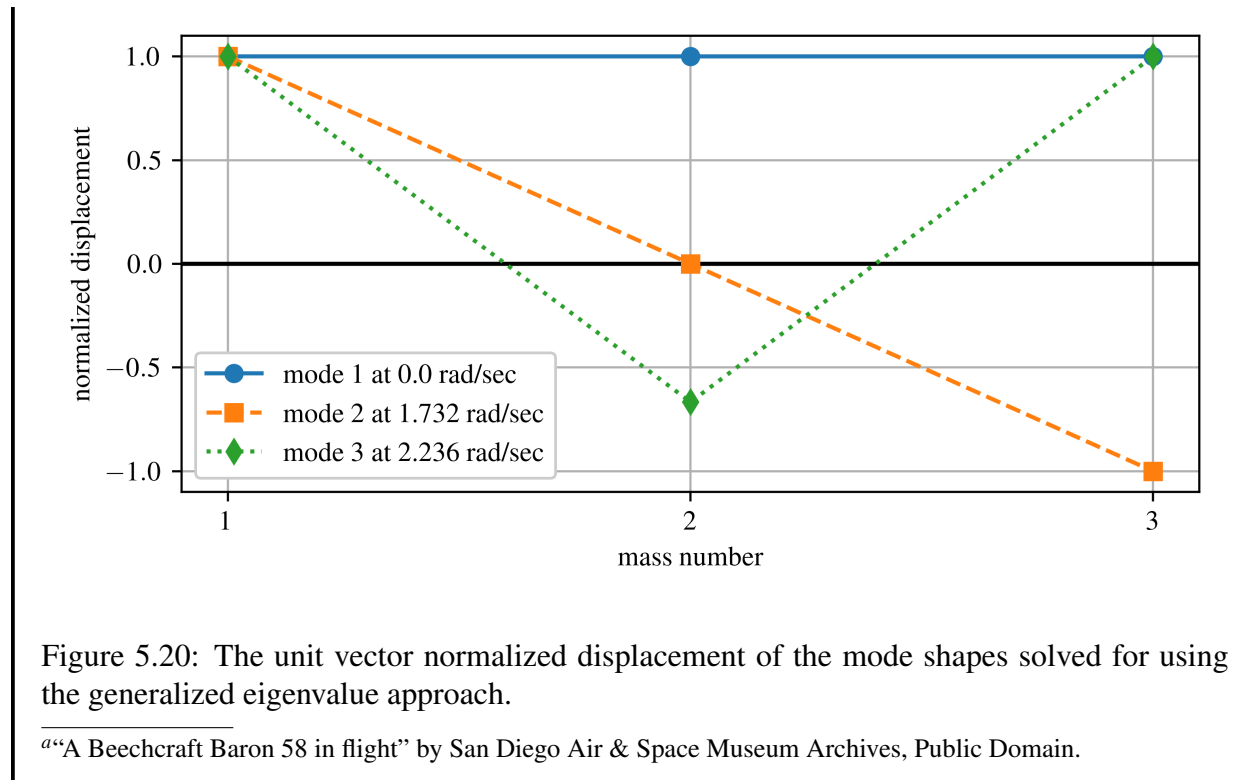

5.7 Modal Analysis

Modal analysis is the study of a system’s dynamic properties and is done in the frequency domain. Consider a system with n degrees of motion, modal analysis allows for the uncoupling of the EOM into n single-degree-of-freedom system (represented as 2nd-order DOF systems) where the displacements of the masses are expressed as the linear summations of the normal modes of the system. If every mode shape is considered, the solution is equivalent to the solution obtained from the original n^{th} -degree-of-freedom system.

Consider the generic multidegree-of-freedom system under external forces, expressed as:

$$M\ddot{\vec{x}} + K\vec{x} = \vec{F} \quad (5.151)$$

where damping is not considered and the vector \vec{F} is a set of deterministic inputs. To expand this equation by modal analysis, the eigenvalue problem must first be solved. The generalized eigenvalue problem is written at:

$$\lambda M\mathbf{v} = K\mathbf{v} \quad (5.152)$$

For the n^{th} -degree-of-freedom, the generalized eigenvalue problem can be simplified to:

$$\omega_i^2 M\vec{v}_i = K\vec{v}_i \quad (5.153)$$

Considering that the total displacement of the system, expressed as $\vec{x}(t)$, is the summation of the displacement of each of the noncontributing modes; assuming a linear system, the temporal response of the system can be written as:

$$\vec{x}(t) = q_1(t)\vec{v}_1 + q_2(t)\vec{v}_2 + q_3(t)\vec{v}_3 + \cdots + q_n(t)\vec{v}_n \quad (5.154)$$

where the time-dependent generalized scalars $q_1(t), q_2(t), \dots, q_n(t)$ are the modal participation coefficients (also called principal coordinates). Defining the modal matrix P as:

$$P = [\vec{v}_1 \ \vec{v}_2 \ \vec{v}_3 \ \dots \ \vec{v}_n] \quad (5.155)$$

where $\vec{v}_1 = M^{-1/2}u_1$ and are the orthonormal eigenvectors of \tilde{K} (i.e. the mass normalized eigenvectors) and not the eigenvectors of the original system formation shown in equation 5.152. Note that the modal matrix is made of of the eigenvectors of \tilde{K} and not the mode shapes of the system; for context see review 5.5.

Review 5.5 Modal Matrix

A modal matrix is a mathematical concept taken from linear algebra and not specific to vibrations or structural dynamics. This is why the modal matrix does not contain the modes of the system but rather eigenvectors.

From linear algebra, the modal matrix B for the matrix A is a matrix of size $n \times n$ consisting of the eigenvectors of A as columns in B . It is used in the definition of matrix similarity such that

$$C = B^{-1}AB \quad (5.156)$$

where C is a $n \times n$ diagonal matrix with the eigenvalues of A on the main diagonal (zeros elsewhere). D is the spectral matrix of A . The eigenvalues must appear in the diagonal (top-left to bottom-right in the same order as their corresponding eigenvectors are arranged in B (column-wise left to right)).

The linear combination of the normal modes (equation 5.154) can be more concisely written as:

$$\vec{x}(t) = P\vec{q}(t) \quad (5.157)$$

where $\vec{q}(t) = [q_1 \ q_2 \ q_3 \ \dots \ q_n]^T$. Next, the relationship that relates the physical space to the modal space for the acceleration component is written as:

$$\ddot{\vec{x}}(t) = P\ddot{\vec{q}}(t) \quad (5.158)$$

combining these two terms results in the EOM that can be written as:

$$MP\ddot{\vec{q}}(t) + KP\vec{q}(t) = \vec{F} \quad (5.159)$$

To convert the EOM into the standard form, first the P^T is multiplied through the equation as:

$$P^T MP\ddot{\vec{q}}(t) + P^T KP\vec{q}(t) = P^T \vec{F} \quad (5.160)$$

If the modes are normalized, the following is true:

$$P^T MP = I \quad (5.161)$$

where I is the identity matrix and

$$P^T KP = \begin{bmatrix} \swarrow & 0 & 0 \\ 0 & \omega^2 & 0 \\ 0 & 0 & \searrow \end{bmatrix} \quad (5.162)$$

Next we define $\vec{Q}(t)$ as vector of generalized forces in the modal space such that $\vec{Q}(t) = P^T \vec{F}$. This results in a EOM in the modal space expressed as:

$$\ddot{\vec{q}}(t) + \begin{bmatrix} \swarrow & 0 & 0 \\ 0 & \omega^2 & 0 \\ 0 & 0 & \searrow \end{bmatrix} \vec{q}(t) = \vec{Q}(t) \quad (5.163)$$

For a system with n degrees of freedom, this equation can be broken down into:

$$\ddot{q}_i(t) + \omega_i^2 q_i(t) = Q_i(t), \quad i = 1, 2, \dots, n \quad (5.164)$$

This expression is the same ODE that we have solved multiple times in this text. Therefore, we know the solution to be:

$$q_i(t) = q_{i0} \cos(\omega_i t) + \frac{\dot{q}_{i0}}{\omega_i} \sin(\omega_i t) \quad (5.165)$$

Lastly, to solve for a solution in the modal space, the initial conditions that were given in the physical space must be converted to the modal space. This can be done by generalizing the velocities in terms of the modal matrix:

$$\vec{q}(0) = P^T M \vec{x}(0) \quad (5.166)$$

$$\dot{\vec{q}}(0) = P^T M \vec{v}(0) \quad (5.167)$$

Example 5.8 Free Vibration Response

Solve for the free vibration response of the 2-DOF presented in figure 5.21 using modal analysis. Show the temporal response for the entire system for its first 20 seconds using the full modal reconstruction and the reconstruction truncated to just include the first mode. Also, plot the variations in the modal participation coefficients through time. Apply the parameters, $f_1 = 0$ N, $f_2 = 0$ N, $m_1 = 10$ kg, $m_2 = 1$ kg, $k_1 = 30$ N/m, $k_2 = 5$ N/m, $k_3 = 1$ N/m, $x_1(0) = 1$ mm, $x_2(0) = 0$ mm, $v_1(0) = 0$ mm/s, and $v_2(0) = 0$ mm/s.

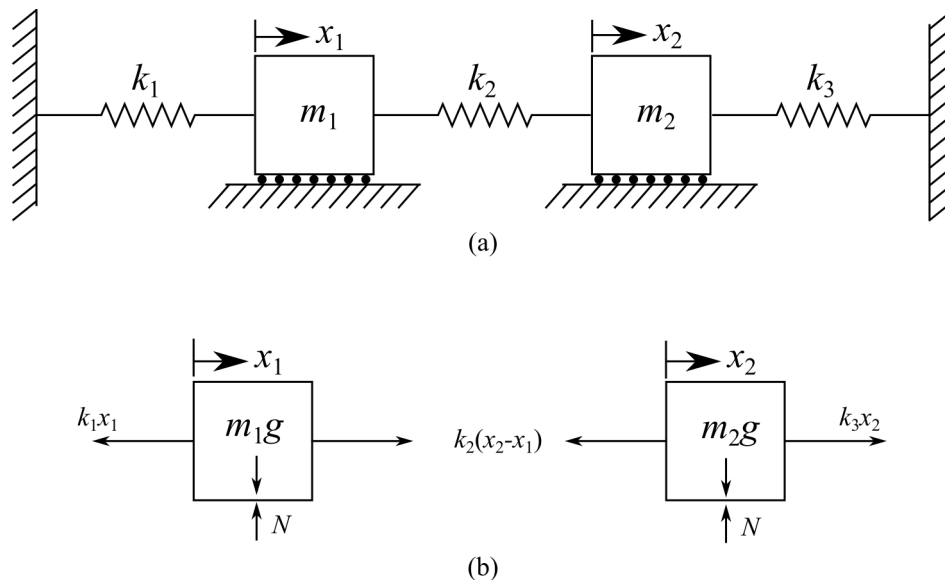

Figure 5.21: Forced 2-DOF damped system showing: (a) system, and (b) FBD.

Solution:

The equations of motion that couple the system are:

$$\begin{aligned} m_1 \ddot{x}_1 + (k_1 + k_2)x_1 - k_2 x_2 &= 0 \\ m_2 \ddot{x}_2 + (k_2 + k_3)x_2 - k_2 x_1 &= 0 \end{aligned} \quad (5.168)$$

In matrix form, these become:

$$\begin{bmatrix} m_1 & 0 \\ 0 & m_2 \end{bmatrix} \begin{bmatrix} \ddot{x}_1 \\ \ddot{x}_2 \end{bmatrix} + \begin{bmatrix} k_1 + k_2 & -k_2 \\ -k_2 & k_2 + k_3 \end{bmatrix} \begin{bmatrix} x_1 \\ x_2 \end{bmatrix} = \begin{bmatrix} 0 \\ 0 \end{bmatrix} \quad (5.169)$$

$$\vec{x}(0) = \begin{bmatrix} 1 \\ 0 \end{bmatrix}, \quad \vec{v}(0) = \begin{bmatrix} 0 \\ 0 \end{bmatrix}$$

The natural frequencies and mode shapes can then be obtained by solving the eigenvalue problem. Setting up the generalized eigenvalue problem:

$$K\mathbf{v} = \lambda M\mathbf{v} \quad (5.170)$$

and solving yields:

$$\lambda_1 = 2.73, \quad \vec{v}_1 = \begin{bmatrix} 0.55 \\ 0.84 \end{bmatrix} \quad (5.171)$$

$$\lambda_2 = 6.76, \quad \vec{v}_2 = \begin{bmatrix} -0.15 \\ 0.99 \end{bmatrix}$$

this is then related to the natural frequency and mode shapes as:

$$\omega_1 = \sqrt{\lambda_1} = 1.65 \text{ rad/s}, \quad \vec{v}_1 = \vec{v}_1 \alpha_1 = \begin{bmatrix} 0.55 \\ 0.84 \end{bmatrix} \alpha_1 \quad (5.172)$$

$$\omega_2 = \sqrt{\lambda_2} = 2.60 \text{ rad/s}, \quad \vec{v}_2 = \vec{v}_2 \alpha_2 = \begin{bmatrix} -0.15 \\ 0.99 \end{bmatrix} \alpha_2 \quad (5.173)$$

recall that the eigenvalues only contain information about the direction of the linear transform, and therefore, their magnitudes are arbitrary. Therefore, they must be scaled proportionally to each other. For this reason, the scalars α_1 and α_2 are added. By orthogonalizing the modal vectors with respect to the mass matrix, the values of α_1 and α_2 are found as:

$$1 = \vec{v}_1^T M \vec{v}_1 \quad (5.174)$$

$$1 = \alpha_1^2 \begin{bmatrix} 0.55 & 0.84 \end{bmatrix} \begin{bmatrix} 10 & 0 \\ 0 & 1 \end{bmatrix} \begin{bmatrix} 0.55 \\ 0.84 \end{bmatrix} \quad (5.175)$$

and:

$$1 = \vec{v}_2^T M \vec{v}_2 \quad (5.176)$$

$$1 = \alpha_2^2 \begin{bmatrix} -0.15 & 0.99 \end{bmatrix} \begin{bmatrix} 10 & 0 \\ 0 & 1 \end{bmatrix} \begin{bmatrix} -0.15 \\ 0.99 \end{bmatrix} \quad (5.177)$$

therefore, $\alpha_1 = 0.52$ and $\alpha_2 = 0.91$.

Applying the proper scaling values to the modal vector, the modal matrix becomes:

$$P = [\vec{v}_1 \ \vec{v}_2] = \begin{bmatrix} 0.284 & -0.14 \\ 0.43 & 0.900 \end{bmatrix} \quad (5.178)$$

Next, check that the normal modes in the modal matrix (P) are normalized, per equation 5.161. This yields,

$$P^T M P = \begin{bmatrix} 1 & -2.775e-16 \\ -2.775e-16 & 1 \end{bmatrix} \approx I \quad (5.179)$$

which is close enough to I. Considering that $\vec{x}(t) = P\vec{q}(t)$, the EOM for the system can be expressed as:

$$\ddot{\vec{q}}(t) + \begin{bmatrix} \omega_1^2 & 0 \\ 0 & \omega_2^2 \end{bmatrix} \vec{q}(t) = \vec{Q} = \begin{bmatrix} 0 \\ 0 \end{bmatrix} \quad (5.180)$$

rewriting this in scalar form for each modal coefficient yields:

$$\ddot{q}_i(t) + \omega_i^2 q_i(t) = 0, \quad i = 1, 2 \quad (5.181)$$

where the solution for this ODE is:

$$q_i(t) = q_{i0} \cos(\omega_i t) + \frac{\dot{q}_{i0}}{\omega_i} \sin(\omega_i t) \quad (5.182)$$

where q_{i0} and \dot{q}_{i0} are the initial conditions in modal space. Therefore, the given initial conditions must be transferred into modal space as:

$$\vec{q}(0) = P^T M \vec{x}(0) = \begin{bmatrix} 0.284 & 0.43 \\ -0.14 & 0.900 \end{bmatrix} \begin{bmatrix} 10 & 0 \\ 0 & 1 \end{bmatrix} \begin{bmatrix} 1 \\ 0 \end{bmatrix} = \begin{bmatrix} 2.85 \\ -1.378 \end{bmatrix} \quad (5.183)$$

$$\dot{\vec{q}}(0) = P^T M \dot{\vec{v}}(0) = \begin{bmatrix} 0.28 & 0.43 \\ -0.14 & 0.90 \end{bmatrix} \begin{bmatrix} 10 & 0 \\ 0 & 1 \end{bmatrix} \begin{bmatrix} 0 \\ 0 \end{bmatrix} = \begin{bmatrix} 0 \\ 0 \end{bmatrix} \quad (5.184)$$

therefore,

$$\begin{aligned} q_1(t) &= 2.85 \cdot \cos(1.65t) \\ q_2(t) &= -1.34 \cdot \cos(2.6t) \end{aligned} \quad (5.185)$$

converting back into the time domain is done knowing $\vec{x}(t) = P\vec{q}(t)$, therefore,

$$\vec{x}(t) = P\vec{q}(t) = \begin{bmatrix} 0.28 & -0.14 \\ 0.43 & 0.90 \end{bmatrix} \begin{bmatrix} 2.85 \cdot \cos(1.65t) \\ -1.38 \cdot \cos(2.6t) \end{bmatrix} \quad (5.186)$$

This is further simplified into:

$$\begin{aligned} x_1(t) &= 0.81 \cdot \cos(1.65t) + 0.19 \cdot \cos(2.6t) \\ x_2(t) &= 1.24 \cdot \cos(1.65t) - 1.24 \cdot \cos(2.6t) \end{aligned} \quad (5.187)$$

These results are plotted in figure 5.22.

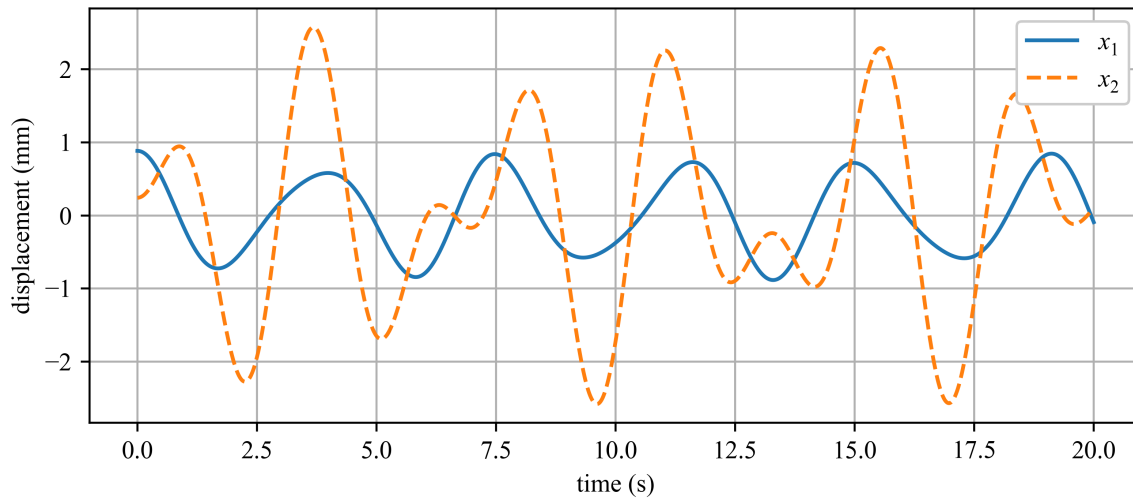

Figure 5.22: Temporal response for the 2-DOF reconstructed using just all the modal coordinates.

Next, the truncated response can be computed by only considering the first mode response for the system (i.e. $\vec{x}(t) = q_1(t)\vec{v}_1$). This is obtained as:

$$\vec{x}(t) = P\vec{q}_{\text{truncated}}(t) = \begin{bmatrix} 0.28 & -0.14 \\ 0.43 & 0.90 \end{bmatrix} [2.85 \cdot \cos(1.65t)] \quad (5.188)$$

This is further simplified into:

$$\begin{aligned} x_1(t) &= 0.81 \cdot \cos(1.65t) \\ x_2(t) &= 1.24 \cdot \cos(1.65t) \end{aligned} \quad (5.189)$$

These results are plotted in figure 5.23. Note that this only considers the response of the system that is a function of the first mode. Note that this captures some of the “general” idea of the system while missing out on the finer points that the 2nd mode contributes.

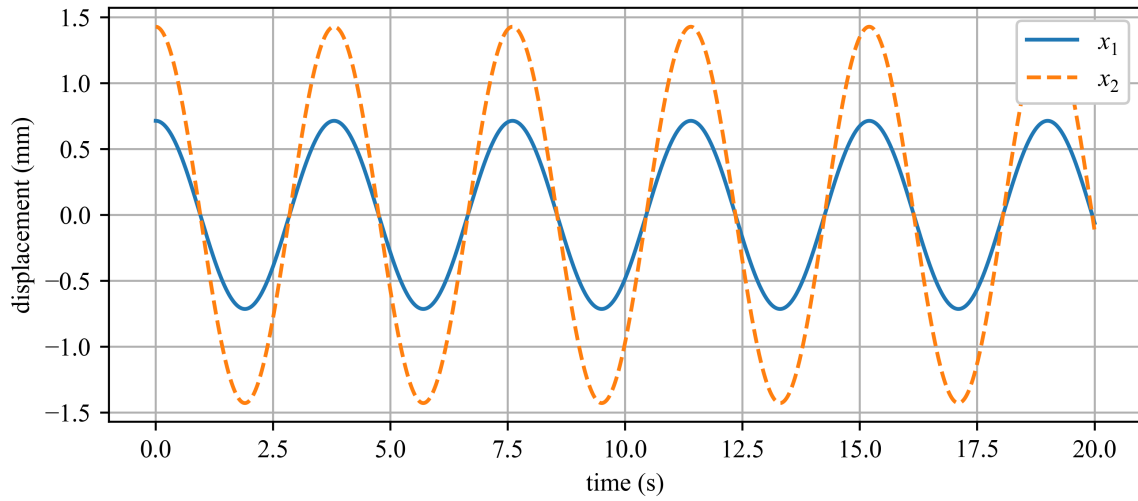

Figure 5.23: Truncated temporal response for the 2-DOF reconstructed using just the first modal coordinates.

Lastly, the participation of the two modes can be plotted from the time series response of equation 5.186.

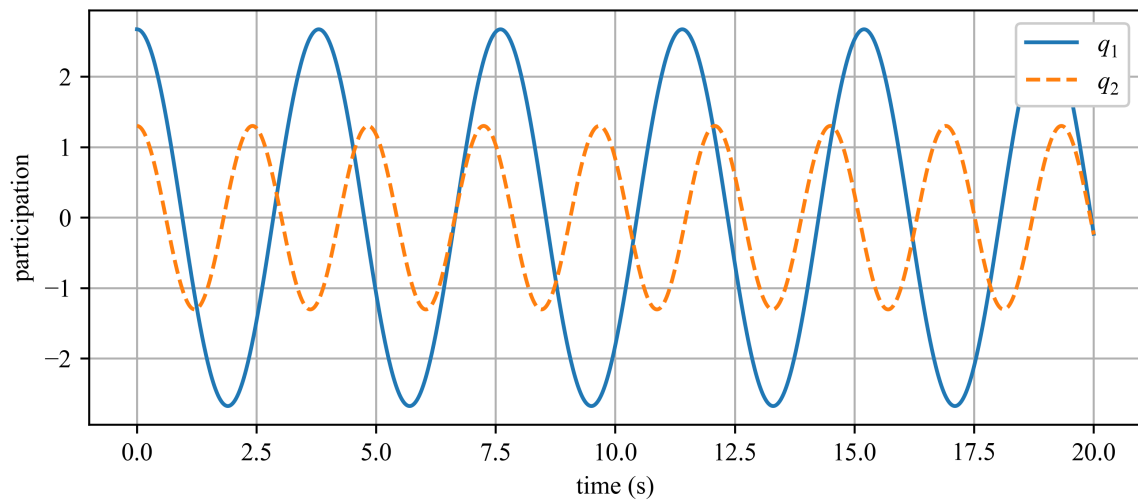

Figure 5.24: Modal participation coefficients.

5.8 Numerical Methods

Numerical methods can be used to solve the response of multi-degree of freedom system subjected to forced vibrations. While not the most computationally efficient method, the EOM is an ODE that can be solved directly while considering the initial directions to obtain the response of the system.

Example 5.9 Directly Solving the ODE of the EOM for a 2-DOF system.

Consider the system presented in figure 5.25(a) where $m_1=2$ kg, $m_2=1$ kg, $k_1 = 20$ N/m, $k_2 = 10$ N/m, $c_1 = 0.5$ kg/s, and $c_2 = 1$ kg/s; initially at rest. m_1 is subjected to the ramp and hold load shown in figure 5.25(b). Using MATLAB, solve the EOM for the temporal response 2-DOF system using a numerical ODE solver.

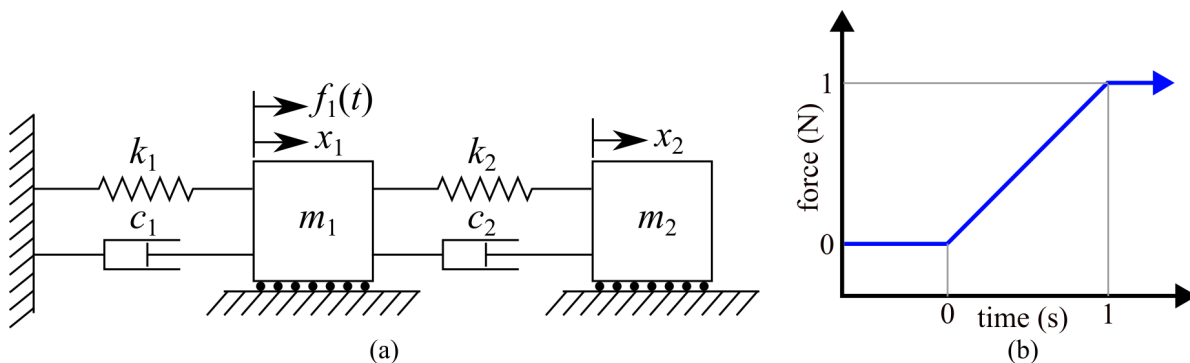

Figure 5.25: 2-DOF system with two masses and two independent confidante systems x_1 and x_2 .

Solution:

Assuming $x_1 < x_2$, the matrix form of the system is

$$\begin{bmatrix} m_1 & 0 \\ 0 & m_2 \end{bmatrix} \begin{bmatrix} \ddot{x}_1 \\ \ddot{x}_2 \end{bmatrix} + \begin{bmatrix} c_1 + c_2 & -c_2 \\ -c_2 & c_2 \end{bmatrix} \begin{bmatrix} \dot{x}_1 \\ \dot{x}_2 \end{bmatrix} + \begin{bmatrix} k_1 + k_2 & -k_2 \\ -k_2 & k_2 \end{bmatrix} \begin{bmatrix} x_1 \\ x_2 \end{bmatrix} = \begin{bmatrix} R(t) \\ 0 \end{bmatrix} \quad (5.190)$$

where $R(t)$ is the piecewise ramp function shown in figure 5.25(b). This expression can be re-arranged to:

$$\ddot{\vec{x}} = M^{-1}(F_t - C \cdot \dot{\vec{x}} - K \cdot \vec{x}) \quad (5.191)$$

which is the format required by MATLAB's ode45 solver. Thereafter, the code in listings 4 and 5 can be used to develop the results shown in figure 5.26.

Listing 4: MATLAB code for solving the EOM of the two-degree-of-freedom system.

```
% Time span for simulation
tspan = [0, 10]; % Start time and end time

% Initial conditions [x1, x1', x2, x2']
```



```

initial_conditions = [0, 0, 0, 0];

% Use ode45 to solve the system of ODEs
[t, y] = ode45(@equations_of_motion, tspan, initial_conditions);

% Extract displacements of masses
x1 = y(:, 1);
x2 = y(:, 3);

```

Listing 5: Functions for Matlab code.

```

% Equations of motion for the system
function [dydt] = equations_of_motion(t, y)

    % Setup the system parameters
    m1=2; m2=1; k1=20; k2=10; c1=0.5; c2=1;

    % Build the Mass, Damping, and Stiffnes matrices
    M = [m1, 0; 0, m2];
    C = [c1 + c2, -c2; -c2, c2];
    K = [k1 + k2, -k2; -k2, k2];

    % Unpack the state variables
    x = y(1:2);
    x_dot = y(3:4);

    % Get the force excitation vector at time t
    F_t = force_excitation_vector(t);

    % Equations of motion
    x_dotdot = inv(M) * (F_t - C * x_dot - K * x);

    % Pack the derivatives into the output vector dydt
    dydt = [x_dot; x_dotdot];
end

% Define the force excitation vector F(t)
function F_t = force_excitation_vector(t)

    if t<1 % Ramp load from 0 to 1 second
        f1_t = t;
    else % constant load after 1 second
        f1_t=1;
    end

    % Force vector, with no load on f2
    F_t = [f1_t; 0];
end

```

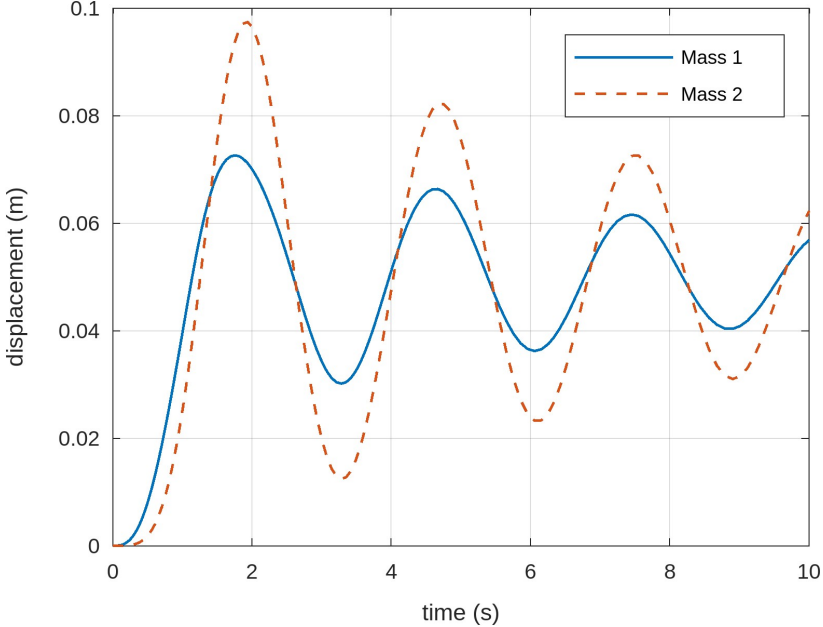
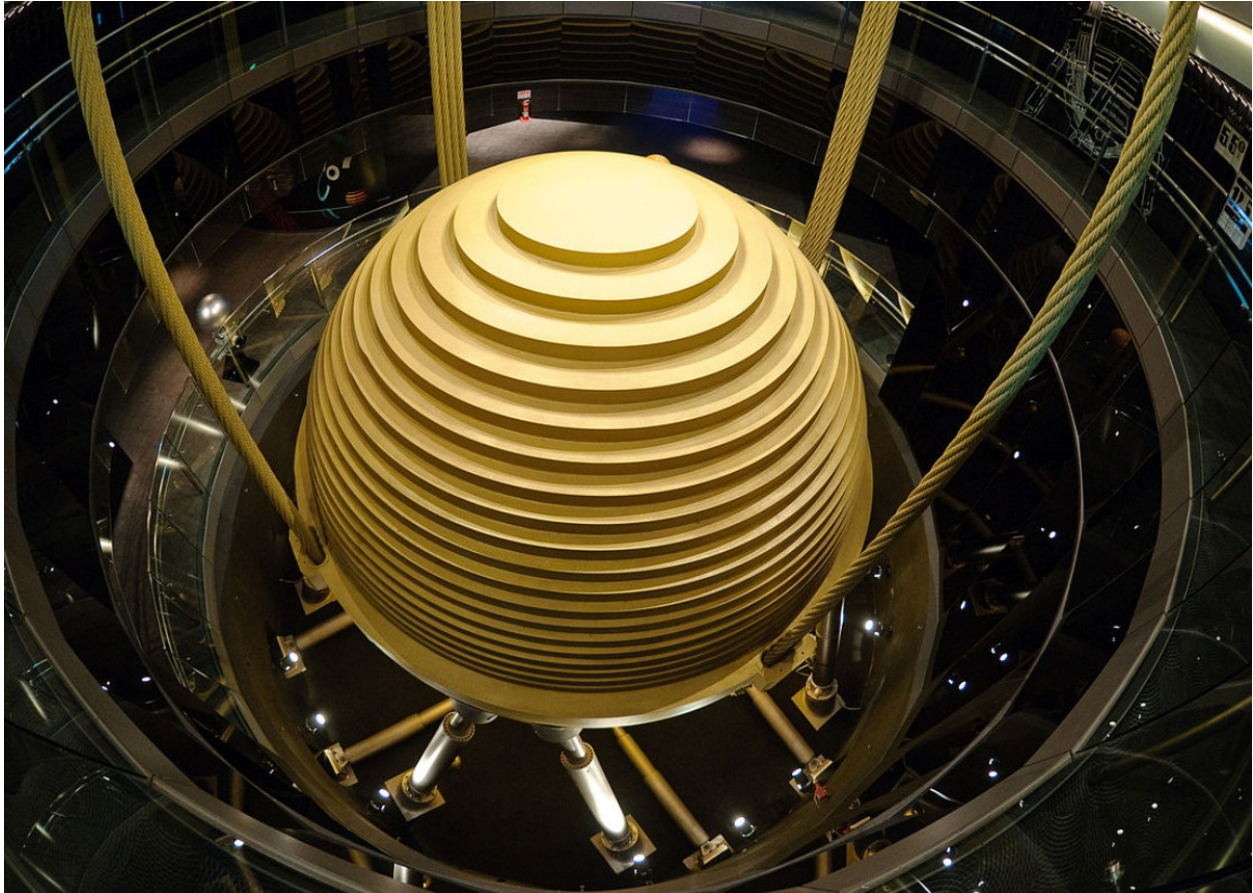

Figure 5.26: Displacement response of the 2-DOF system.

Part II

Applied Topics



The tuned mass damper inside Taipei 101. The largest damper ball in the world, weights 660-metric-tons and consists of 41 circular steel plates that are 125 mm (4.92 in) thick. ^a

^aArmand du Plessis, CC BY 3.0 <<https://creativecommons.org/licenses/by/3.0/>>, via Wikimedia Commons

6 Vibration Control

Throughout this text, we have studied various aspects related to analyzing and modeling vibrating systems. Therefore, it becomes prudent to look at methods for reducing or eliminating unwanted vibrations. However, before vibrations in a system can be effectively reduced they must be better understood in terms of their effects on the system under study. For this reason, this chapter first introduces the vibration Nomograph, which is then followed by vibration isolation, absorption, and active suppression.

6.1 Vibration Nomograph

There exist various methods and standards for measuring and describing acceptable levels of vibrations in systems, these include ISO/AWI 2631 for the evaluation of human exposure to whole-body vibrations and ISO 4866 for the measurement and effects of vibrations on structures. A common way to present the acceptable limit of vibration is in a vibration nomograph. A vibration nomograph is a simplified way to express the acceptable limits on a system while considering the displacement, velocity, acceleration, and frequency of a system. A typical nomograph with various limits is presented in figure 6.1.

A vibration nomograph is a logarithmic plot that allows us to easily express the relationships between displacement, velocity, acceleration, and frequency of a system. The vibration nomograph presented in figure 6.1 considers an undamped 1-DOF system with constant amplitude (A) experiencing harmonic motion that can be modeled as:

$$x(t) = A \sin(\omega t) \quad (6.1)$$

Therefore, the velocity and acceleration terms can be found by taking the derivatives of the displacement expression to yield:

$$\dot{x}(t) = A\omega \cos(\omega t) \quad (6.2)$$

and:

$$\ddot{x}(t) = -A\omega^2 \sin(\omega t) \quad (6.3)$$

These equations are converted from a circular frequency in rad/sec to a linear frequency (f) in Hz, such that $\omega = 2\pi f$. Therefore, equations 6.1-6.3 become:

$$x(t) = A \sin(\omega t) \quad (6.4)$$

$$v(t) = \dot{x}(t) = 2\pi f A \cos(\omega t) \quad (6.5)$$

$$a(t) = \ddot{x}(t) = -4\pi^2 f^2 A \sin(\omega t) \quad (6.6)$$

Thereafter, the maximum values for velocity v_{\max} and acceleration a_{\max} are related to amplitude through:

$$v_{\max} = 2\pi f A \quad (6.7)$$

$$a_{\max} = -4\pi^2 f^2 A = -2\pi f v_{\max} \quad (6.8)$$

by taking the natural log of both sides of equation 6.7 we obtain:

$$\ln v_{\max} = \ln(2\pi f) + \ln A \quad (6.9)$$

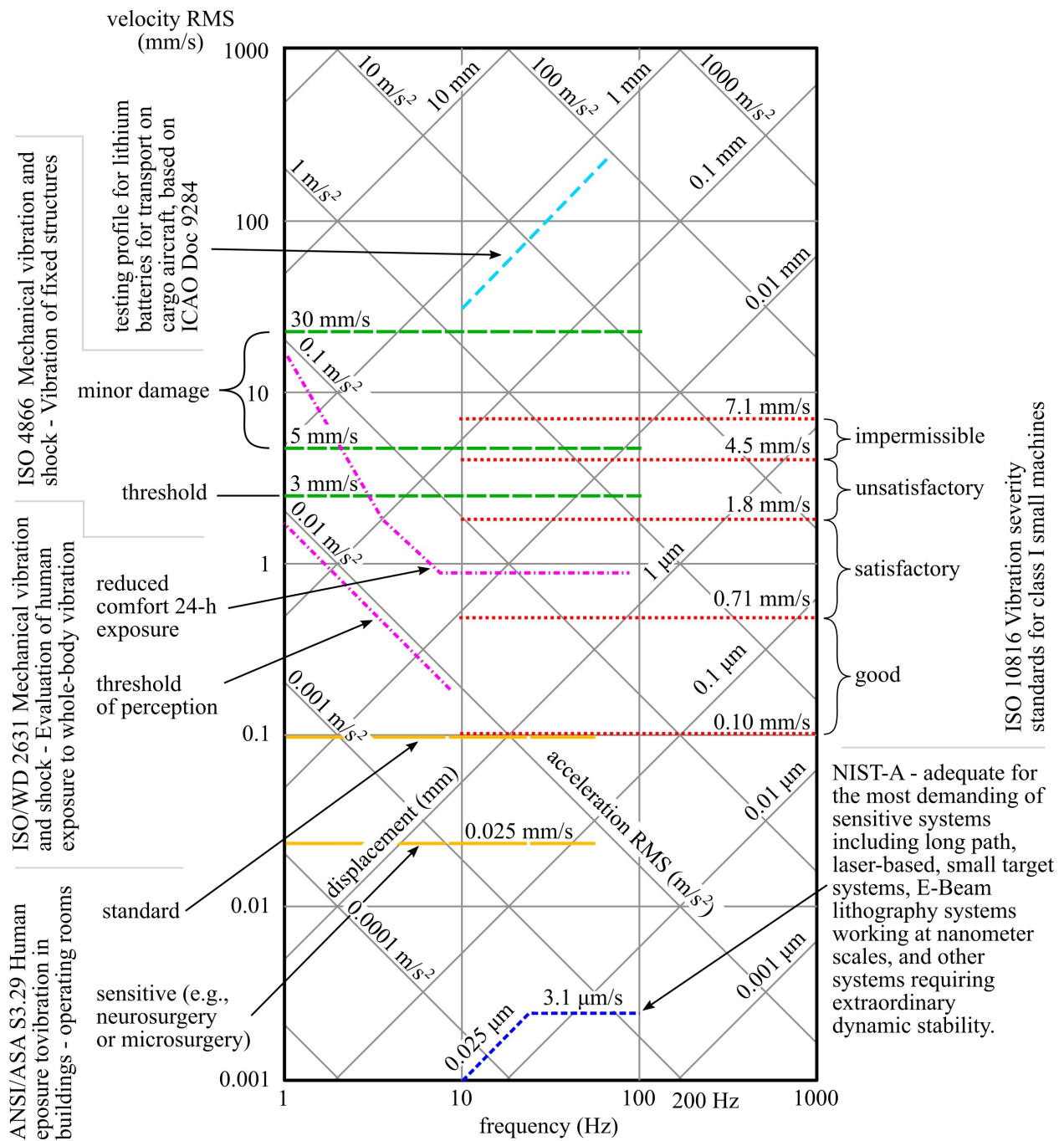

Figure 6.1: Vibration nomograph showing a unified representation of the acceptable limits of vibration for various applications.

doing the same for equation 6.8 leads to:

$$\ln a_{\max} = -\ln(2\pi f) - \ln v_{\max} \quad (6.10)$$

It can be seen that both of these expressions are linear.

The nomograph sets the x -axis as frequency in Hz and the y -axis as velocity in mm/s. Equation 6.9 tells us that For a constant amplitude of displacement (A), $\ln v_{\max}$ is linearly proportional to $\ln(2\pi f)$, at a rate of 2π . As the x -axis in a nomograph is frequency, measured in Hz and thereby accounting for the 2π , $\ln(2\pi f)$ is a straight line with a positive slope of 1 with respect to the frequency axis (i.e. x -axis). Therefore, a line on the nomograph that represents a constant displacement is at a 45° angle from the x -axis.

For a constant value of velocity, (v_{\max}), equation 6.10 shows that acceleration ($\ln a_{\max}$) is linearly proportional to $-\ln(2\pi f)$, at a rate of 2π . Again, as the x -axis in a nomograph is frequency, measured in Hz, acceleration is represented by a straight line that varies with $-\ln(2\pi f)$, therefore, $\ln a_{\max}$ is a straight line with the slope of -1. This is also represented by a line of constant acceleration set at a -45° angle from the x -axis. These equations are expressed in the vibration nomograph plot of figure 6.1 where each point on the plot represents a specific sinusoidal (harmonic) vibration for a 1-DOF system.

6.2 Vibration Isolation

To mitigate vibrations in a system the ideal approach would be to limit the source of vibrations. However, this is not always applicable to the system you are considering. Therefore, isolating the system from vibrations is the next best step. One approach to this is to design systems around limiting the force and displacement transmissibility discussed prior; where both force and displacement transmissibility are considered *isolation problems*.

One way to do this is to track the *transmissibility ratio* which is denoted as T.R. and defines the ratio of the magnitude of the transmitted (F_T) to applied force (F_0).

$$\text{T.R.} = \frac{F_T}{F_0} = \sqrt{\frac{1 + (2\zeta r)^2}{(1 - r^2)^2 + (2\zeta r)^2}} \quad (6.11)$$

Vibration Case Study 6.1 Vibration Control Through Better Design

Vibration mitigation can be achieved through better system-level design. For example, early rubber tires consisted of uniform tread patterns, but as cars became faster the noise, vibration, and harshness (NVH) generated by the tire would be constrained around a single frequency; thereby amplifying NVH felt by the driver and passengers. This challenge led to the development of tires with irregular tread patterns to spread the energy created at the road/tire interface out over a wider bandwidth of excitation; thereby reducing NVH felt and heard by the passengers.

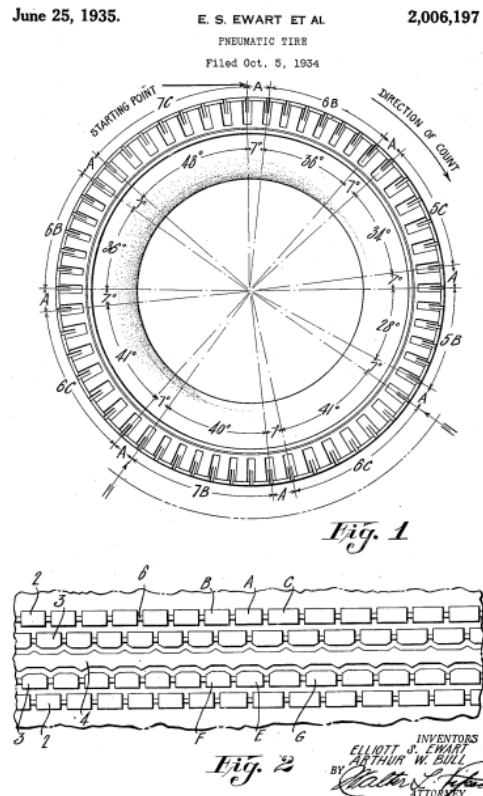

Figure 6.2: Illustration for the 1935 US patent which proposed the use of irregular tread patterns to control the pitch of road noise^a.

^aUS patent number US2006197A, inventors Elliott S Ewart and Arthur W. Bull; Public Domain

6.3 Vibration Absorption

Vibration absorbers, also termed dynamic vibration absorbers, are a class of mechanical devices that seek to reduce unwanted vibrations in a system. In contrast to a traditional dash-pot style damper, these systems seek to “redirect” the vibrations from the system to another mass connected to the system. In this way, the main system is protected from the bandwidth of vibrations that the vibration absorbers are tuned for. As the vibration absorbers must be tuned for the system, it is generally limited to devices that operate at a fixed frequency like industrial equipment or cables suspended in the air and subjected to wind loading. Figure 6.3 presents a Stockbridge and a

Dogbone damper designed to remove certain bandwidths of excitation from wind-excited cables.

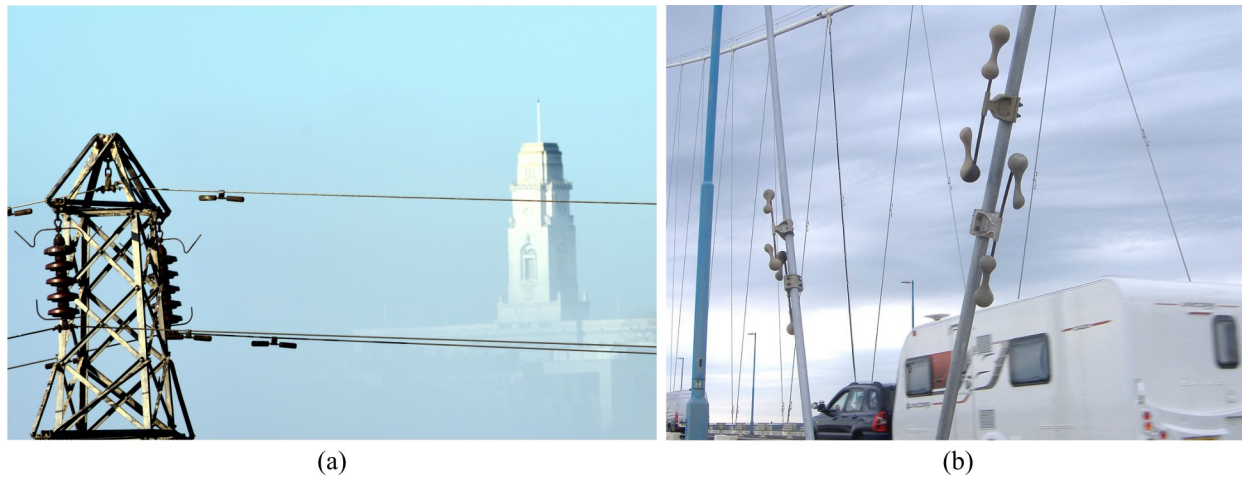

Figure 6.3: Vibration absorbers deployed on wind excited cables showing: (a) a Stockbridge damper on a high-power transmission line^a, and; (b) a dogbone damper on a suspender cable of a suspension bridge^b.

6.3.1 Vibration Absorption for Undamped Systems

Vibration absorbers are most often designed to shift the resonance frequency of the first mode of the system away from the expected excitation frequency. This is done by adding an additional degree-of-freedom in the form of a mass (the vibration absorber) connected to the system with a spring to alter the natural frequency of the combined system away from the original excitation frequency. Dashpots may also be added in parallel to the spring element if additional energy dissipation is needed beyond that provided by the original system.

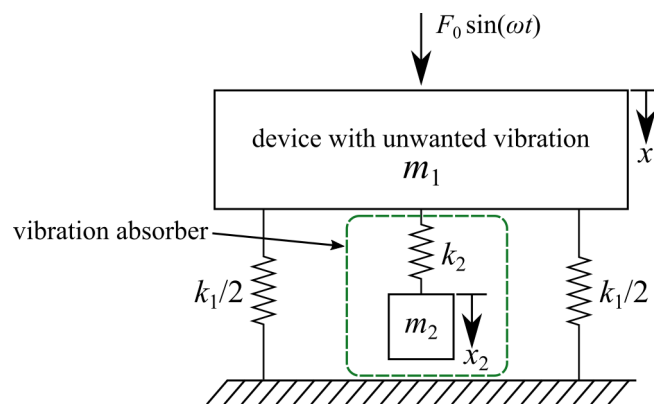

Figure 6.4: A vibration absorber (m_2) for mitigating unwanted dynamics in a device (m_1).

^a“Stockbridge dampers installed on high voltage power lines” by Badics CC BY-SA 3.0

^b“Dogbone dampers on the road-support cables of the Severn Bridge” by Bassaar CC BY-SA 4.0

The tuning of a 2-DOF system can be done by setting the displacement of the mass to be controlled to zero and solving for the mass and stiffness of the vibration absorber. Consider the system presented in figure 6.4, here m_1 and k_1 are the mass and stiffness of the system while m_2 and k_2 are the mass and stiffness of the vibration absorber. A good assumption to make when designing a vibration absorber is that the mass of the vibration absorber should be between 1% and 5% of the mass of the system to be damped. Therefore, for this case let $m_1 = 20$ kg, $m_2 = 1$ kg, and $k_1 = 20$ kN. Assuming a sinusoidal input where $F_0 = 1$ kN, the equations of motion are:

$$m_1\ddot{x}_1 + k_1x_1 + k_2(x_1 - x_2) = F_0 \sin(\omega t) \quad (6.12)$$

$$m_2\ddot{x}_2 + k_2(x_2 - x_1) = 0 \quad (6.13)$$

Assuming the temporal solution is of a harmonic form, the following is true:

$$x_i(t) = X_i \sin(\omega t), \quad i = 1, 2 \quad (6.14)$$

using the transfer function approach and assuming no initial conditions, the following steady-state solution can be obtained for m_1 and m_2 :

$$X_1 = \frac{(k_2 - m_2\omega^2)F_0}{(k_1 + k_2 - m_1\omega^2)(k_2 - m_2\omega^2) - k_2^2} \quad (6.15)$$

$$X_2 = \frac{k_2F_0}{(k_1 + k_2 - m_1\omega^2)(k_2 - m_2\omega^2) - k_2^2} \quad (6.16)$$

Next, the natural frequency of m_1 (ω_1) can be solved for as $\omega_1 = \sqrt{k_1/m_1}$. In order to eliminate movement for m_1 at a given driving frequency ω , the numerator of equation 6.15 should be set to zero. Note that setting F_0 to zero is a trivial solution and provides no benefit to the system in terms of vibration control. Therefore:

$$k_2 = m_2\omega^2 \quad (6.17)$$

note that this will force the frequency of the tuned vibration absorber to match that of the system, therefore $\omega_1 = \omega_2 = \sqrt{k_2/m_2}$. Next, normalizing the input force F_0 by the stiffness of the main system k_1 yields:

$$\delta_{st} = \frac{F_0}{k_1} \quad (6.18)$$

using this term, equations 6.15 and 6.16 can be rearranged as:

$$\frac{X_1}{\delta_{st}} = \frac{1 - \left(\frac{\omega}{\omega_2}\right)^2}{\left[1 + \frac{k_2}{k_1} - \left(\frac{\omega}{\omega_1}\right)^2\right] \left[1 - \left(\frac{\omega}{\omega_2}\right)^2\right] - \frac{k_2}{k_1}} \quad (6.19)$$

$$\frac{X_2}{\delta_{st}} = \frac{1}{\left[1 + \frac{k_2}{k_1} - \left(\frac{\omega}{\omega_1}\right)^2\right] \left[1 - \left(\frac{\omega}{\omega_2}\right)^2\right] - \frac{k_2}{k_1}} \quad (6.20)$$

Figure 6.5 reports the normalized displacement of the system over a frequency range for the system with and without a vibration absorber. Note that at $\omega = 1$ the original system is in resonance while the system with the vibration absorber has no displacement. However, no system is without

compromise. From equation 6.20 it can be seen that at $\omega = \omega_1 = \omega_2$ the second mass needs a displacement equal to:

$$X_2 = -\frac{k_1}{k_2} \delta_{st} = -\frac{F_0}{k_2} \quad (6.21)$$

or 1 m using the given parameters. Therefore, the mass and stiffness values of the vibration absorber should be selected based on the allowable travel of the vibration absorber (i.e. X_2), among other factors. Moreover, from this equation it can be seen the force exerted by the second mass operates in the direction opposite the original force ($-F_0 - k_2 X_2$), thereby canceling it. Lastly, note that the addition of the vibration absorber creates two resonate frequencies of the system, termed Ω_1 and Ω_2 . These resonate frequencies represent the roots of the system and care should be taken to limit the time the system spends at these frequencies (i.e. on startup). The locations of these roots can be solved analytically by setting the denominators of equation 6.19 to zero.

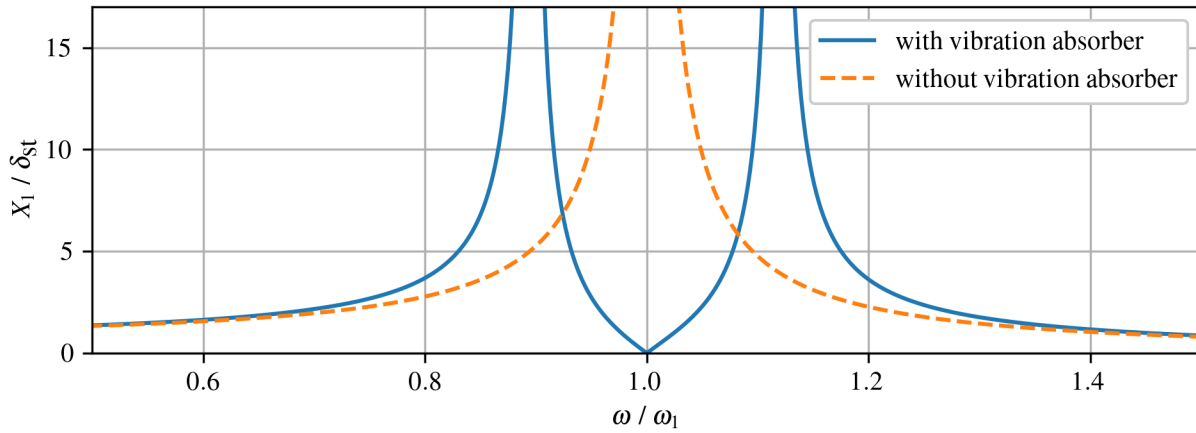

Figure 6.5: Frequency response of the undamped system with and without the vibration absorber.

6.3.2 Vibration Absorption for Damped Systems

As shown in section 6.3.1 and figure 6.5 in particular, vibration absorption for undamped systems only shift the resonance response from part of the spectrum to another. However, it is communally desired to limit the resonance response of the system while also absorbing vibration energy at one specific frequency. While not derived here, the frequency response of a damped vibration absorber like that shown in figure 6.4 (but with the addition of a damper) can be expressed as the dimensionless amplitude of the response of the primary mass:

$$\frac{X_1}{\delta_{st}} = \sqrt{\frac{(2\zeta r)^2 + (r^2 - \beta^2)^2}{(2\zeta r)^2 (r^2 - 1 + \mu r^2)^2 + (\mu r^2 \beta^2 - (r^2 - 1)(r^2 - \beta^2))^2}} \quad (6.22)$$

This expression requires four design variables $[\mu, \beta, r, \zeta]$ to be set by the practitioner. First, ω_1 is the natural frequency of the primary mass onto which the vibration absorber is attached, and is defined as:

$$\omega_1 = \sqrt{k_1/m_1} \quad (6.23)$$

which leads to a similar expression for the frequency of the vibration absorber $\omega_2 = \sqrt{k_2/m_2}$. Next, we define the ratio of natural frequencies $\beta = \omega_2/\omega_1$ and the ratio of the masses $\mu = m_2/m_1$. However, to function as a vibration absorber, it is often desired to set $\beta = 1$. Next, we build an expression for the “mixed damping ratio”:

$$\zeta = \frac{c}{2m_2\omega_1} \quad (6.24)$$

where c is the damping value of the added damper. Again, we define $r = \omega/\omega_1$ to create a variable of the driving frequency to the frequency of the system. Figure 6.6 shows how the selection of the four design variables $[\mu, \beta, r, \zeta]$ results in different spreads of the response of the primary system mass. As the mixed damping ratio increases, the response of the system converges on that of a system without a vibration absorber as the system mass and vibration absorber are more tightly coupled.

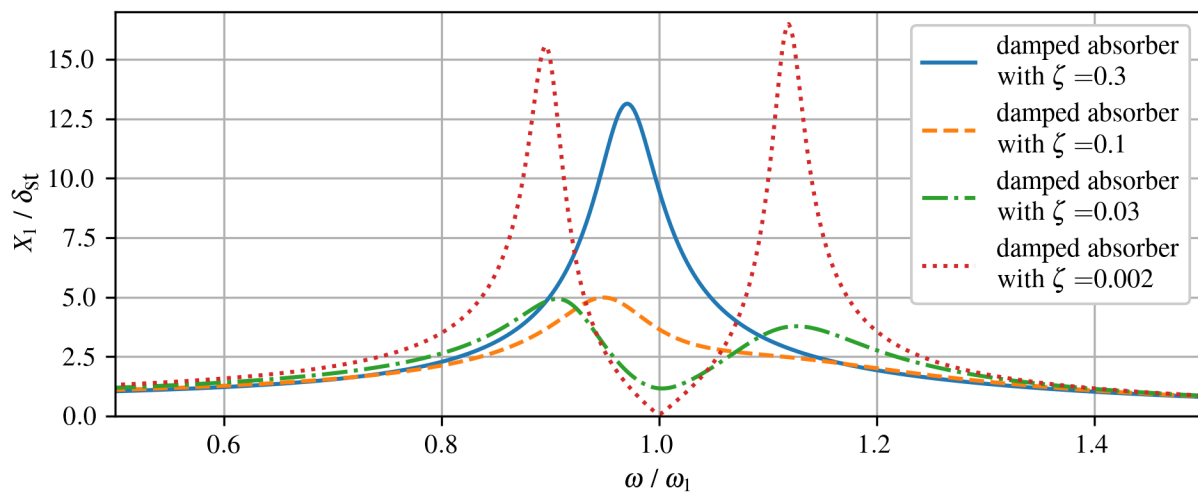

Figure 6.6: Frequency response of a 1-DOF system with various damped vibration absorbers.

Vibration Case Study 6.2 Tuned Mass Dampers in Civil Structures

Figure 6.7: Illustration of Taipei 101's main tuned mass damper. ^a

A tuned mass dampers (TMD), also known as a harmonic absorber or seismic damper, are devices that are designed into a structure to mitigate structural vibration. The mass is typically a block of steel or concrete and is mounted on suspended cables to create a pendulum and damped in relation to the structure. By tuning the oscillating frequency of the damping system to be near the same natural frequency of the structure, energy is transferred to the mass and extracted through the dampers. Thereby reducing vibration which prevents discomfort or damage. While discussed here in the context of tall buildings, tuned mass dampers are also frequently found in automobile components and power transmission lines.

^aadapted from Someformofhuman, CC BY-SA 4.0 <<https://creativecommons.org/licenses/by-sa/4.0/>>, via Wikimedia Commons

6.4 Active Vibration Suppression

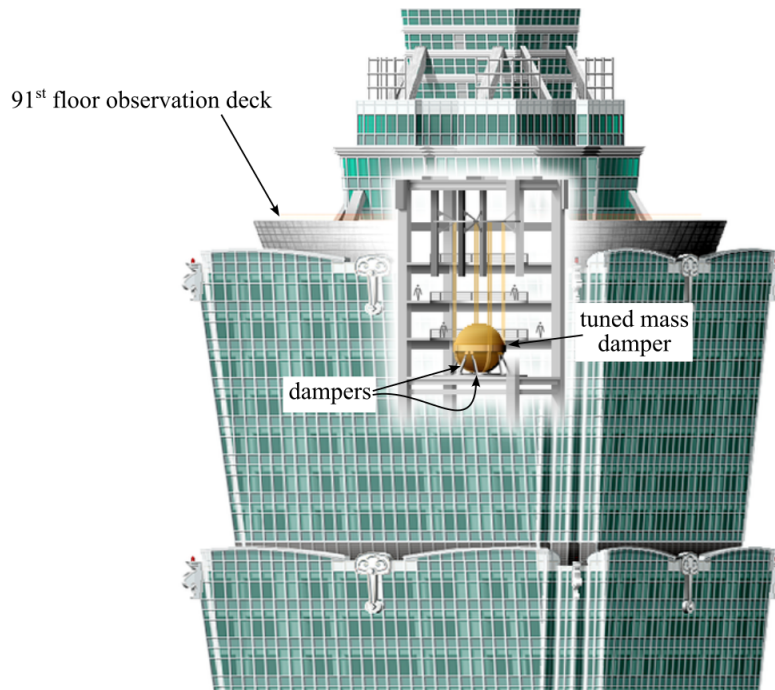
Vibrations in systems can be mitigated through a number of active systems; typically it's easiest to consider this as an actuator that adds energy to the system at the correct time to cancel out vibrations.

6.4.1 Metrics for Vibration Control

There are various performance indicators that one can use to judge the performance of an active control scheme. They depend on the system order (1st, 2nd) and the excitation experienced by the system. For simplicity in this introductory text, we will define four performance indicators subjected to a step response, each shown in figure 6.8. The performance indicators are:

- peak time (t_p) is the time to the first peak.
- peak value (x_p) is the maximum value experiences by the system
- settling time (t_s) is the time it takes the system to get within an error ($\pm\epsilon\%$) of the steady-state displacement (x_{ss}) and stay there.
- max percentage overshoot (M_p) is defined as $M_p = (x_p/x_{ss} - 1) \cdot 100$.

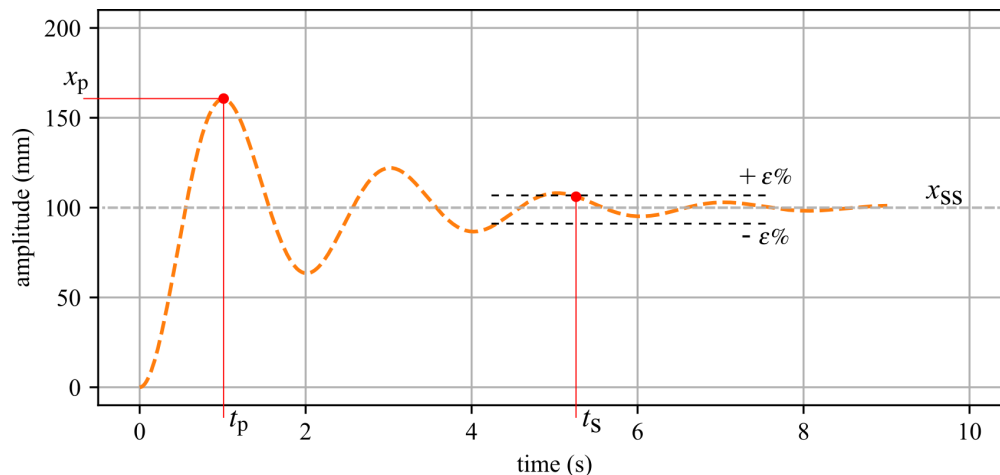

Figure 6.8: Graphical representation of key 2nd order performance indicators

6.4.2 Position-Derivative (PD) Control

Active vibration control adds energy to the system in order to mitigate the vibrations in the system. As depicted in figure 6.9(a), an active vibration control system requires a sensor to acquire data from the system, control hardware, and algorithms to process this data, and an actuator to exert physical control on the system. These systems together are called a feedback loop, as a movement in the mass results in a controlled force (f_u) being exerted on the system. This control force is diagrammed in figure 6.9(b).

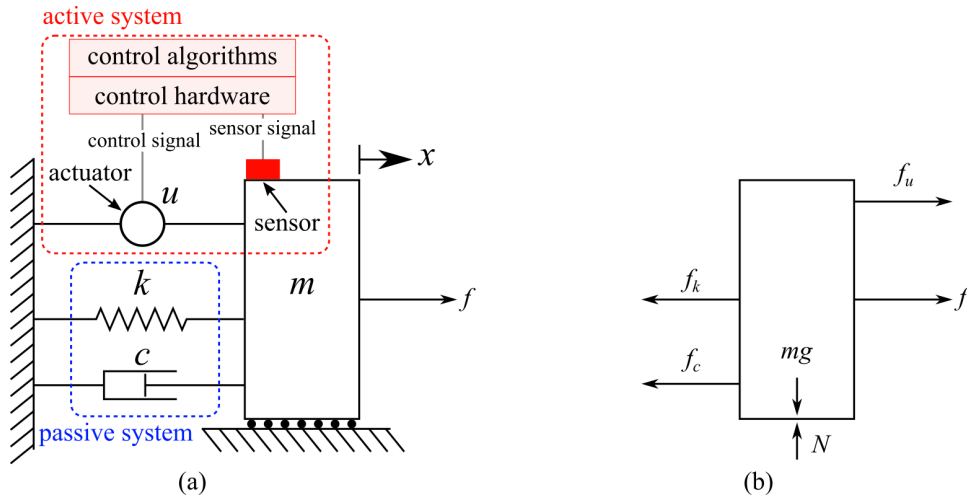

Figure 6.9: Active vibration control system showing: (a) the system with a feedback loop that takes a signal from the sensor, converts it to a control signal, and drives the actuator; and (b) the free body diagram.

Adding the control force to the EOM for the 1-DOF system presented in figure 6.9 results in:

$$m\ddot{x} + c\dot{x} + kx = F(t) = f + f_u \quad (6.25)$$

A common method for providing control for vibration suppression is called position and derivative control or PD-control. A PD-controller is a state-variable feedback controller as it uses velocity and displacement obtained from the measured acceleration, assuming that the acceleration is properly integrated. PD-control measures the position and velocity of the mass and uses these to compute the control force needed to mitigate the vibration to an acceptable level. A simple way to code a PD-controller is to provide a control force proportional to the displacement velocity (derivative of displacement) of the mass such that:

$$f_u = -g_1x - g_2\dot{x} \quad (6.26)$$

where g_1 and g_2 are the proportional gains of the systems. The control gains can be constants determined by the designer or variables updated through time by an algorithm. Here we will consider the gains to be constant, therefore, the EOM for the closed-loop system in figure 6.9 becomes:

$$m\ddot{x} + (c + g_2)\dot{x} + (k + g_1)x = F(t) = f \quad (6.27)$$

This formulation lets g_1 act as additional stiffness while g_2 acts as additional damping. This closed-loop EOM can be used to solve for the effective natural frequency of the system, given by:

$$\omega_n = \sqrt{\frac{k + g_1}{m}} \quad (6.28)$$

and the effective damping ratio of the system

$$\zeta = \frac{c + g_2}{2\sqrt{m(k + g_1)}} \quad (6.29)$$

Review 6.1 Nicolas Minorsky and the Need for Better Control

Continuous control systems have been widely used for centuries. For example, consider that the centrifugal governor which uses spinning weights was used by Christiaan Huygens in the 1600s in the Netherlands to regulate the gap between millstones in windmills or by James Watt who famously linked a stem regulator to a centrifugal governor to control steam turbines.

Arguably, the Russian American engineer Nicolas Minorsky was the first to develop the theoretical analysis for the three-term control we now call PID. This was done in 1922 while he was researching and designing automatic ship steering for the US Navy. He based his work on watching how a ship's helmsman responds to wave loading on a ship, with a delayed input to the helm that not only considered the current ship course but also past errors and the desired rate of change for the ship. For a helmsman, the goal is stability, not absolute control, which simplifies how one thinks about the challenge of control.

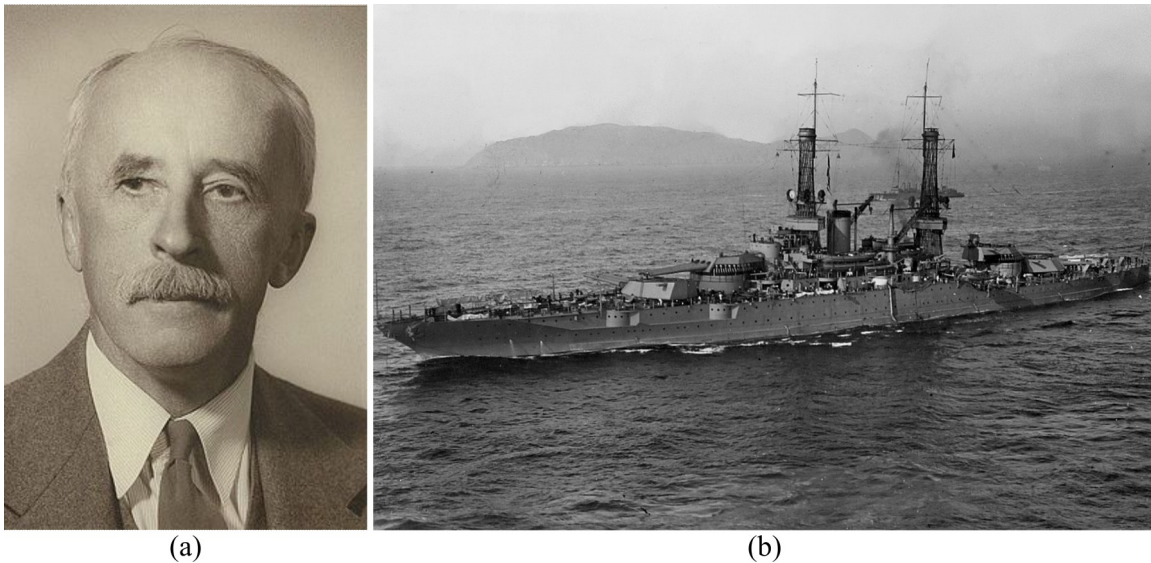

Figure 6.10: Historical perspective of PID control showing: (a) Portrait of Nicolas Minorsky^a and (b) the battleship USS New Mexico (BB-40) of the United States Navy which was the first to implement PID control in its steering^b.

^aPeter Minorsky, grandson of Nicolas Minorsky, CC BY-SA 1.0 <<https://creativecommons.org/licenses/by-sa/1.0/>>, via Wikimedia Commons

^bU.S. Navy, Public domain, via Wikimedia Commons

6.4.3 Proportional-Integral-Derivative (PID) Control

Proportional-Integral-Derivative (PID) Control is a three-term controller that employs feedback that is widely used in continuous control systems, including for the control of structural systems. A PID controller seeks to minimize the measured error value $e(t)$ between a desired setpoint (SP) and a measured process variable (PV) by applying corrections based on the proportional (P), integral (I), and derivative (D) terms (denoted P, I, and D respectively), from which it gets its name.

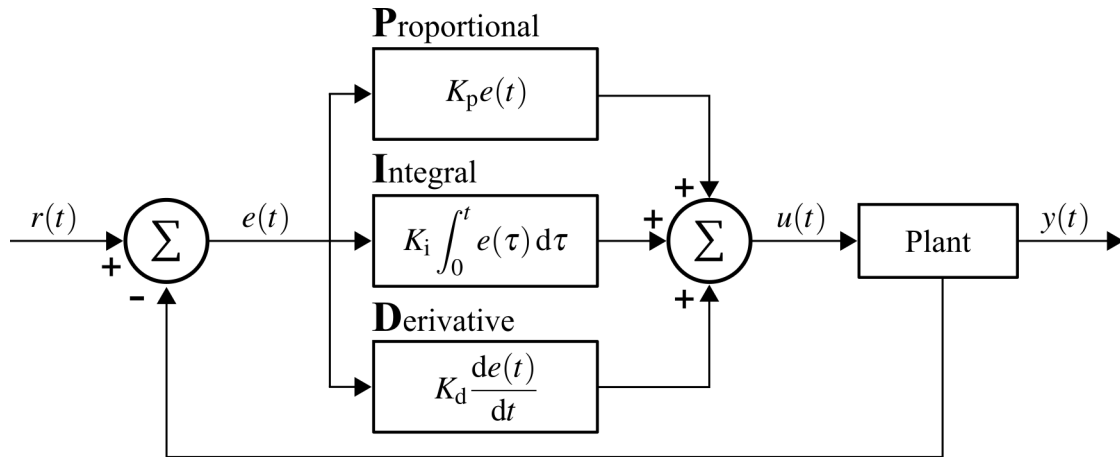

Figure 6.11: Generalized PID controller for a system with feedback, where $r(t)$ is the desired setpoint (SP) and $y(t)$ is the measured process value (PV).

The overall control equation is defined as

$$u(t) = K_p e(t) + K_i \int_0^t e(\tau) d\tau + K_d \frac{de(t)}{dt} \tag{6.30}$$

where K_p , K_i , and K_d are non-negative coefficients for the proportional, integral, and derivative terms, respectively. The PID controller is diagrammed in figure 6.11 for a system with feedback control, such as that shown in figure 6.9. Moreover, in the Laplace-derived s domain, the transfer function of the PID controller is defined as

$$\mathcal{L}[s] = K_p + \frac{K_i}{s} + K_d s \tag{6.31}$$

where s is the complex frequency. A temporal response for the 1-DOF shown in figure 6.9 when controlled with a PID controller is reported in figure 6.12.

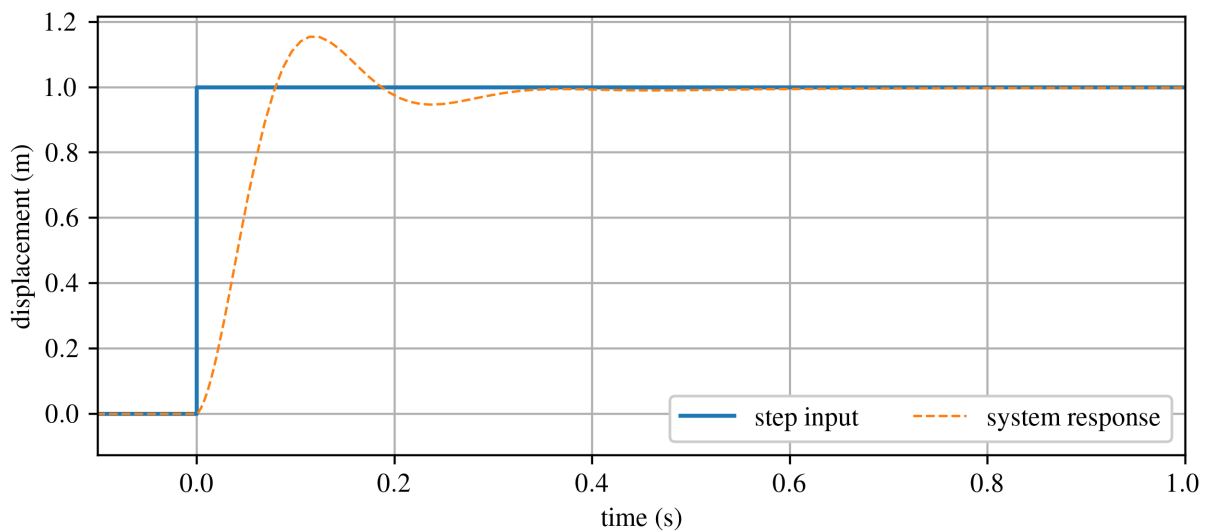

Figure 6.12: System response for a 1-DOF system controlled with a PID.

7 Experimental Vibrations

Experimental testing requires the practitioner to understand the basics of testing hardware and digital signal processing. An understanding of how to acquire and process vibration data is key to being able to apply one's knowledge of vibrations to real-world systems.

Vibration Case Study 7.1 Challenges in Structural Monitoring

On August 14, 2018, the Ponte Morandi viaduct in Genoa Italy collapsed, killing 43 and displacing hundreds of people from their homes. The Morandi viaduct was a cable-stayed bridge with uniquely few stays, typically only two per span. The Stays were a hybrid of steel cables overlaid with concrete. The concrete overlay made the direct inspection of the stays impossible.

While the exact cause may never be known, is suspected that one of the stay cables within the concrete failed due to corrosion and poor maintenance causing a bridge with very little redundancy in its design to fail^a.

In 2017, researchers from the Polytechnic University of Milan instrumented and studied the vibration characteristics of the bridge and noted that the modal frequencies of the stays on pillar 9 (the one that collapsed) were more than 10% different than other stays on the bridge. While it's always hard to draw conclusions from one test, comparing modal frequencies between two similar structures can be useful for tracking damage.



Figure 7.1: The Ponte Morandi bridge, showing the bridge: a) before the collapse^b, and; b) after collapse^c.

^aRymsza, Janusz. "Causes of the Collapse of the Polcevera Viaduct in Genoa, Italy." Applied Sciences 11, no. 17 (2021): 8098. <https://doi.org/10.3390/app11178098>.

^bDavide Papalini, CC BY-SA 3.0 <<https://creativecommons.org/licenses/by-sa/3.0/>>, via Wikimedia Commons

^cMichele Ferraris, CC BY-SA 4.0 <<https://creativecommons.org/licenses/by-sa/4.0/>>, via Wikimedia Commons

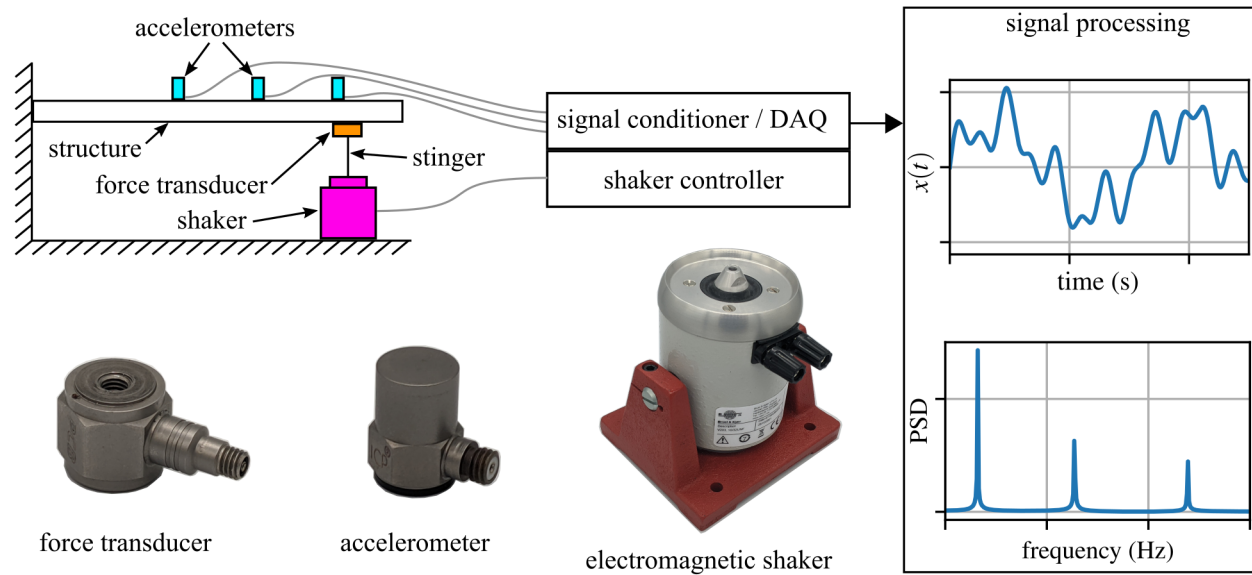

Figure 7.2: Key components for performing experimental modal analysis.

The measurement of vibrating systems requires specialized hardware. While a variety of vendors sell vibration measurement systems in a number of form factors, the general hardware requirements remain constant. The basic hardware requirements are: *Exciter* - A system to provide a measurable input to the system, *Transducers* - Sensors used for converting the mechanical movements of the structure to signals, and *data acquisition* - Hardware for digitizing the signal generated by the transducers. Figure 7.2 shows some of the key systems required for vibration testing and their interactions.

7.1 Sensing and Data Acquisition

The output of a vibrating system is measured through a combination of sensors and data acquisition systems.

7.1.1 Accelerometers

Accelerometers are by far the most common type of sensor used for measuring vibrations. Various types of Accelerometers exist, including Micro-electromechanical systems (MEMS) based systems that are commonly found in cell phones, piezo-resistive-based systems used for high acceleration loading (greater than $10,000 g_n$), or piezo-electric sensors commonly deployed in industrial settings. In terms of dedicated vibration testing, piezo-electric sensors are the most common sensor system.

Piezo-electric sensors use a piezo-electric material to convert small movements into a small electrical charge (measured in Coulomb) in and out of the piezo-electric material. On its own, the signal encoded by this charge is hard to measure and susceptible to electromagnetic noise if run over medium to long wires. Therefore, amplifiers are added to the sensors to assist in transferring this signal back to the data acquisition; thereby creating Integrated Electronics Piezo-Electric (IEPE) sensors. Figure 7.3(a) shows the cross section of a common IEPE sensor. Through

tuning the piezo-electric material and packaging, IEPE sensors can be made to measure a variety of applications (figure 7.3(b)). Table 1 reports specifications for five different IEPE sensors that are used to measure a range of applications from the structural motion of buildings to packages subjected to high-shock loading (e.g., missiles, plane crashes).

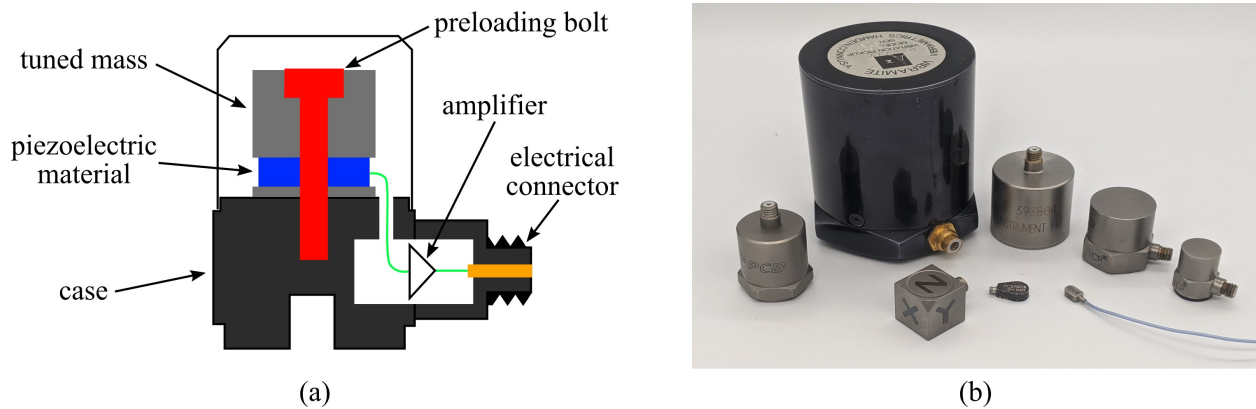

Figure 7.3: Integrated Electronics Piezo-Electric (IEPE) accelerometers, showing: (a) the cross-section of a typical IEPE) accelerometer with key components annotated, and; (b) selection of IEPE accelerometers for various applications.

Table 1: Specifications for various IEPE accelerometers.

specifications	accelerometers				
model number	PCB 393B31	PCB 393B04	PCB 352C67	PCB 352A21	PCB 352A92
Sensitivity($\pm 10\%$)	10.0 V/g	1000 mV/g	100 mV/g	10 mV/g	0.25 mV/g
Measurement Range	± 0.5 g pk	± 5 g pk	± 50 g pk	± 500 g pk	± 20 kg pk
Frequency Range($\pm 5\%$)	0.1 to 200 Hz	0.06 to 450 Hz	0.5 to 10 kHz	1.0 to 10 kHz	1.2 to 10 kHz
Resonant Frequency	>700 Hz	>2.5 kHz	>35 kHz	>50 kHz	>100 kHz
Non-Linearity	$\leq 1\%$	$\leq 1\%$	$\leq 1\%$	$\leq 1\%$	$\leq 1\%$
Transverse Sensitivity	$\leq 5\%$	$\leq 5\%$	$\leq 5\%$	$\leq 5\%$	$\leq 5\%$

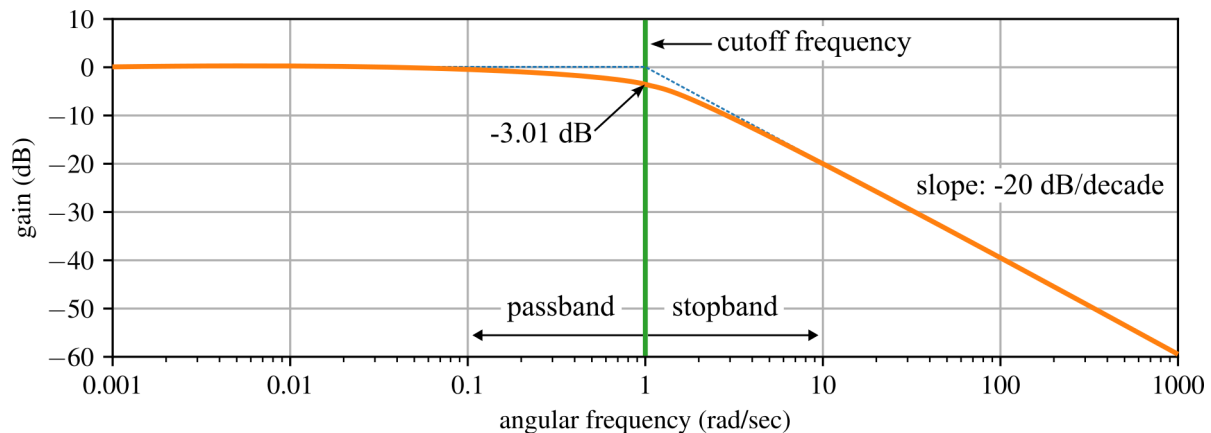

Figure 7.4: Graph of a generic frequency roll-off where the cutoff frequency is at -3.01 dB^a.

The *frequency range* of a sensor reports the frequency of vibration the sensor is designed to acquire. The upper limit is defined as the cutoff frequency of the sensor which is typically defined as the frequency at which the sensor experiences -3.0 dB (relative unit) of signal power loss. However, at -3.0 dB the power of the measured signal is about half as strong as that of the ideal signal. Figure 7.4 shows a generic frequency roll-off chart. For the practitioner, it is important to note that the signal starts to die off well before the cutoff frequency. Therefore, it is important to be cognizant of a sensor's frequency response when trying to obtain measurements of signals near the upper end of an accelerometer.

7.1.2 Data Acquisition

Acquiring data from sensors was once a challenging task that has been greatly simplified by the development of modern hardware and software systems that are far too numerous to list here. One important item to note here is that IEPE sensors require IEPE data acquisition system, as shown in figure 7.5. As IEPE sensors generate very small signals, they require amplification before they can be accurately measured. Therefore, an IEPE data acquisition system consists of a front-end amplifier that is specifically designed to amplify these small signals, a signal conditioning circuit that filters and shapes the signals, and an analog-to-digital converter (ADC) that converts the analog signals to digital signals to be analyzed by a computer.

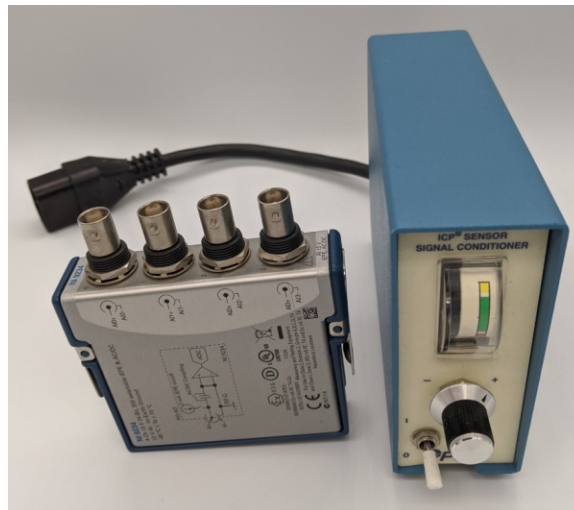

Figure 7.5: Integrated Electronics Piezo-Electric (IEPE) data acquisition systems in various form factors.

^aPDerivative work: KrishnavedalaOriginal: Omegatron, CC BY-SA 3.0 <<https://creativecommons.org/licenses/by-sa/3.0/>>, via Wikimedia Commons

7.2 Controlled Force Excitation

To develop an accurate understanding of vibrating systems, it is important to understand the energy input. Moreover, it is important to test systems under the vibration inputs they may encounter during transportation, operation, or storage as this can help identify potential weaknesses or design flaws in the product.

7.2.1 Modal Hammers

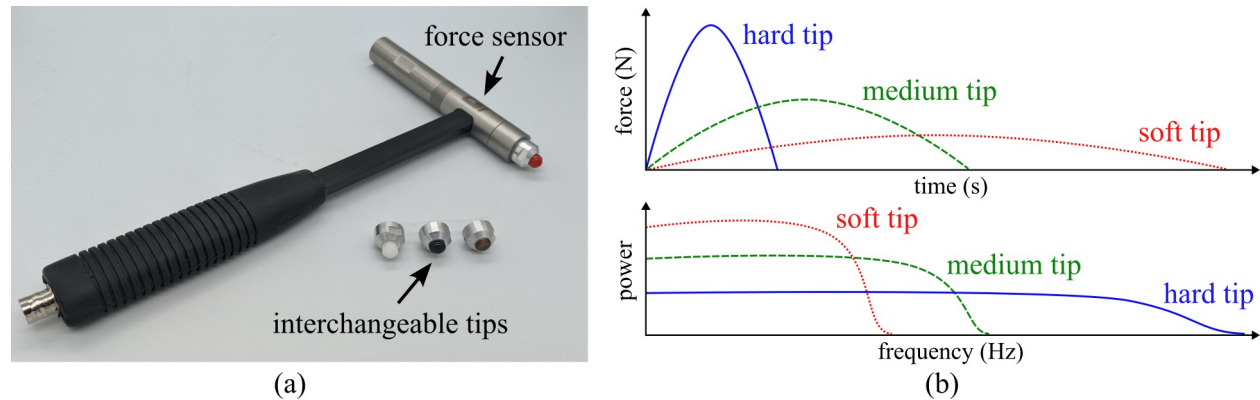

Figure 7.6: Model hammer, showing: (a) instrumented hammer with interchangeable tips, and; (b) the temporal and frequency response from various tips.

A modal hammer is an instrumented hammer used to impart a measured impact force into the structure. The frequency range of the resulting vibrations is determined by the duration of the impact. A shorter impact duration leads to higher frequencies being excited. To achieve varying frequency bandwidths with the same amount of impact energy, special hammer tips of different stiffnesses can be utilized. Figure 7.6 shows a model hammer with interchangeable tips and the responses generated by the tips. In general, there are three factors to be considered when selecting the proper modal hammer.

Factor 1: Frequency bandwidth. Softer hammer tips result in longer pulse durations and narrower frequency bandwidths, while harder tips lead to shorter pulse durations and broader frequency bandwidths. However, when using a hard tip, the power spectral density of the excitation may be insufficient to excite vibration modes in the system. In such cases, increasing the impact force by swinging the hammer harder or adding a head extender may be attempted, but there is a risk of overloading the IEPE force transducer. An alternative solution is to switch to a hammer model with a larger measurement range or use a softer tip to concentrate the impact energy at lower frequencies. Moreover, the duration of the pulse may also be affected by the stiffness of the specimen being impacted.

Factor 2: Energy of the impact. The diverse shapes, masses, and material properties (e.g., stiffness or damping) of objects being tested necessitate a range of force pulses with varying parameters to achieve optimal excitation. Compact objects typically have higher resonance frequencies and require less energy to be excited than larger objects. As a result, a short-duration force pulse can be generated using small or medium-sized hammers. In contrast, larger structures require higher-energy impacts, which are typically concentrated in a low-frequency bandwidth. Modal hammers are available in various masses with measurement ranges ranging from 100 N to 20 kN, allowing practitioners to deliver force pulses with different energies without requiring large swings. As large swings make it difficult to control the force and angle of the hammer tip's impact on the structure.

Factor 3: Tests repeatability. Hammer impacts performed by the practitioner during testing may vary in terms of impact energy, the frequency bandwidth of excited vibrations, and the angle of impact. Therefore, it is common practice to average multiple results obtained during testing to develop high-quality and consistent data.

7.2.2 Electrodynamic Shakers

An electrodynamic shaker can generate a wide range of frequencies and amplitudes that simulate different vibration environments to simulate real-world vibration environments. This is in contrast to a modal hammer that only subjects the measured item to an impulse force. An electrodynamic shaker is shown in figure 7.2. It consists of a strong electromagnet that generates a magnetic field and a moving coil. When an alternating electrical current is passed through the coil, it generates a magnetic field that interacts with the magnet, causing the instrumented system to vibrate. The vibration produced by the electrodynamic shaker can be controlled by adjusting the frequency, amplitude, and waveform of the electrical signal applied to the coil through an amplifier.

7.3 Digital Signal Processing

An analog signal is a continuous-time signal that can take any value within a certain range, while a digital signal is a discrete-time signal that takes on only a finite number of values at discrete time intervals. Digitization in signal processing is the process of converting an analog signal into a digital form.

7.3.1 Sampling and Quantization

The process of digitization involves two main steps: sampling and quantization and is visualized in figure 7.7 for a sinusoidal and a more complex signal. In the sampling step, the continuous analog signal is measured at regular time intervals, known as the sampling rate; measured in samples-per-second (S/s). The resulting discrete-time signal is a sequence of samples that represent the value of the analog signal at each sampling instant. In the quantization step, each sample is converted from its continuous value to a digital value that can be represented using a finite number of bits. The accuracy of the digitized signal depends on the number of bits used for quantization; the more bits used, the more accurately the signal can be represented.

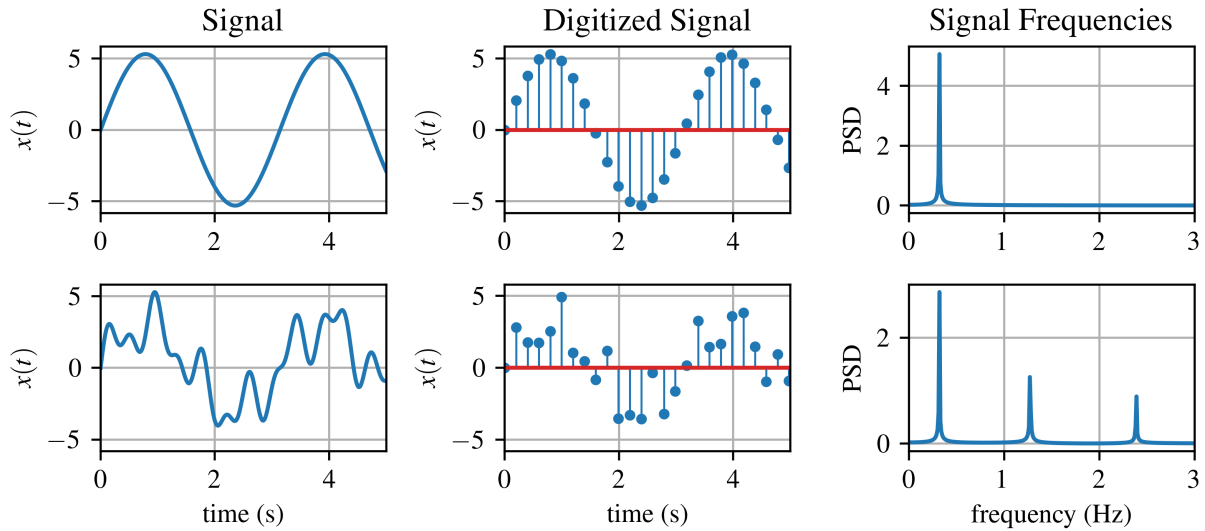

Figure 7.7: Digitization of two continuous time-series signals sampled at 5 S/s.

Review 7.1 Harry Nyquist

Harry Nyquist (February 7, 1889 - April 4, 1976) was a Swedish physicist and electronic engineer. His parents emigrated to the U.S. in 1907. He attended the University of North Dakota starting in 1912 where he obtained a B.S. in 1914 and an M.S. in 1915, both in electrical engineering (entry to M.S. was 3 years!). Thereafter, he went to Yale University where he received a Ph.D. in physics in 1917.



Figure 7.8: Picture of Harry Nyquist from the American Institute of Physics.^a

^aFair use, via Wikimedia Commons

7.3.2 Aliasing

In signal processing, aliasing is an effect that causes different signals to become indistinguishable from each other, as shown in figure 7.9. In this way, the signals become an alias of one another when sampled. Aliasing accounts for the development of distortion or artifact in a reconstructed signal when compared to the original continuous signal. Aliasing occurs when a continuous-time signal is sampled at a rate that is too low, resulting in a higher-frequency component in the signal being incorrectly represented as a lower-frequency component due to undersampling.

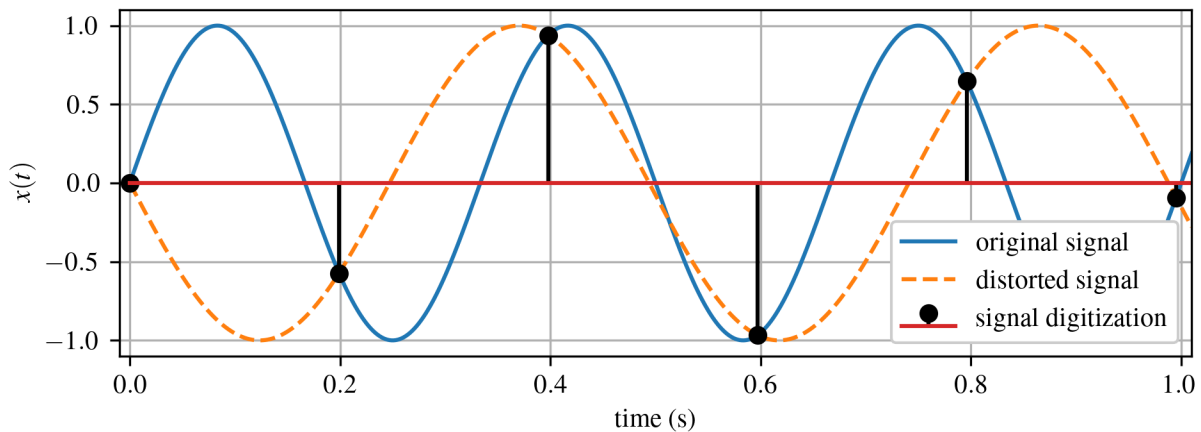

Figure 7.9: Aliasing of a 3 Hz signal that is sampled at 5 S/s where the 3 Hz signal folds back on itself to create a 2 Hz signal.

The Nyquist-Shannon sampling theorem is a theorem in the field of signal processing that defines the sample rate that permits a discrete sequence of samples to sample a continuous-time signal of finite bandwidth. It states that a signal must be sampled at a rate at least twice its highest frequency component to be accurately the frequency domain of the signal; this is known as the Nyquist limit. Otherwise, the higher-frequency components of the signal will “fold” back into the lower-frequency range, resulting in a distorted representation of the signal. Moreover, the signal must be sampled at twice its highest frequency component with one additional sample to accurately reproduce the temporal domain of the signal. For example, suppose a sine wave with a frequency of 3 Hz is sampled at a rate of 5 S/s; as diagrammed in figure 7.9. According to the Nyquist-Shannon sampling theorem, the signal should be sampled at a rate of at least 6 S/s plus one sample to rebuild the signal in the temporal domain. Because the sampling rate is lower than the Nyquist rate, the higher-frequency component of the signal (3 Hz) will be aliased to a lower frequency (2 Hz), resulting in the distorted representation of the signal shown by the dashed orange line in figure 7.9.

Rebuilding discretely sampled continuous signals requires much more than just sampling at the Nyquist limit of $2 \times$ the desired frequency content of the signal plus one additional data point. This is because the Nyquist limit only applies to rebuilding perfect sinusoidal signals and real-world signals are complex. A good rule of thumb is that a signal must be sampled at least 10 times per cycle to accurately rebuild the temporal response of the signal.

7.3.3 Time-Frequency Analysis

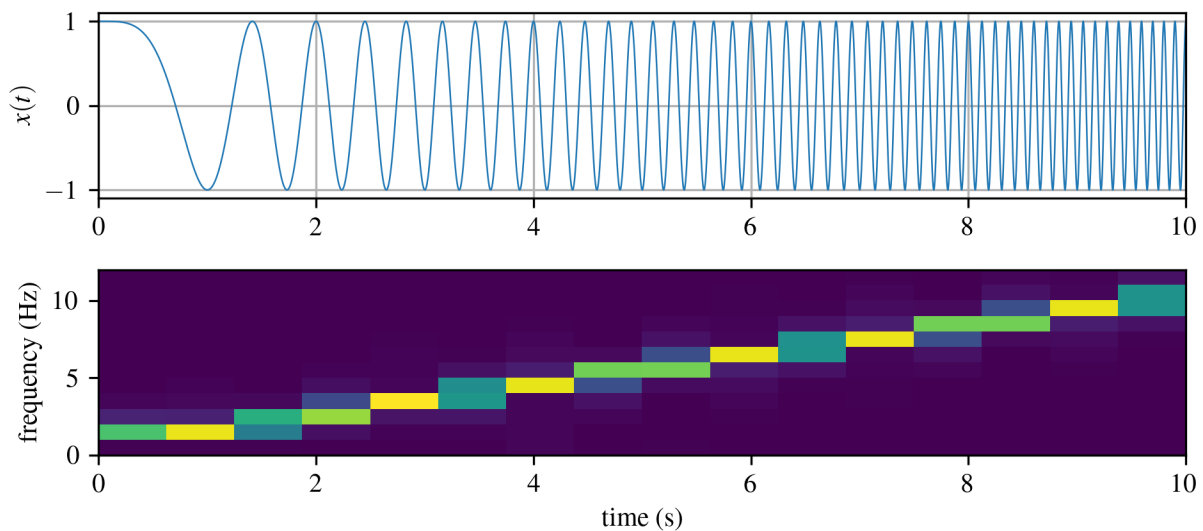

Figure 7.10: Spectrogram of a 0-10 Hz chirp signal.

The frequency components of a signal can change over time, requiring time-frequency techniques to analyze. Of these, a spectrogram such as that shown in figure 7.10 is a visual representation of the spectrum of frequencies of a signal over time. The spectrogram is created by dividing the signal into short time windows and computing the Fourier transform of each window. By applying the Fourier transform to each time window of the signal, the spectrogram displays the variation of the frequency content of the signal over time. Spectrograms can be used for a variety of purposes, such as identifying and analyzing patterns in the frequency content of a signal, detecting and visualizing changes in the frequency content over time, and identifying specific frequency components that may be associated with modes of the vibrating system.

8 Structural Dynamics

The dynamic response of civil infrastructures, including buildings, bridges, and towers, can be studied by applying fundamental vibrations concepts studied in the previous chapters.

8.1 Single-story frame

Let's start by considering the single-story frame shown in figure 8.1 (a) in free vibration (no external load is applied to the structure). The frame has height H and bay width L . As shown in figure 8.1, the frame consists of two columns with a modulus of elasticity E and moment of inertia (second moment of the cross-sectional area) I . The columns are fixed at the base. The frame in figure 8.1 (a) can be modeled as a single-degree of freedom (SDOF) system under the following assumptions:

- Shear building: flexible columns ($EI \neq 0$), beam infinitely rigid ($EI_b = \infty$), axial deformations of beams and columns negligible ($EA = 0$);
- Lumped mass system: floor-mass concentrated at the floor level.

Figure 8.1 (b) illustrates a SDOF with mass m and stiffness k that can be used to model the dynamic behavior of the single-story frame considering no damping ($\zeta = 0$).

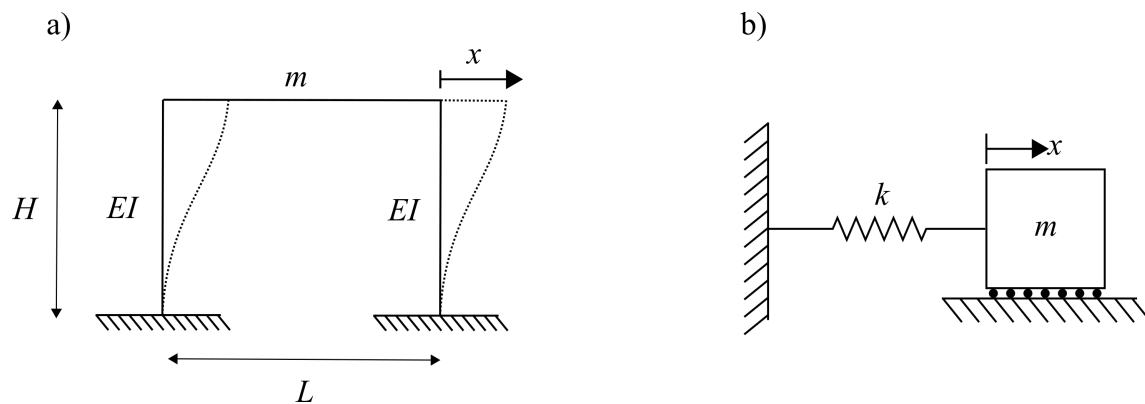

Figure 8.1: (a) Single story frame; (b) undamped single degree of freedom system.

The response of a SDOF system can be written in general notation as:

$$x(t) = x_0 \cos(\omega_n t) + \frac{v_0}{\omega_n} \sin(\omega_n t) \quad (8.1)$$

where ω_n is the natural frequency of the frame, x_0 and v_0 are the initial conditions. In order to find ω_n , we need to calculate the stiffness of the system. The mass is usually given.

The stiffness of the system can be found by applying Hooke's law: $F = kx$. To find k , let's imagine applying an arbitrary lateral force F to the frame and analyzing a single column. At the top, the column will be subjected to a force F and to a moment M_0 , as schematically shown in figure 8.2 (a). Applying the equilibrium equations to the column, it can be found that $M_0 = \frac{FH}{2}$.

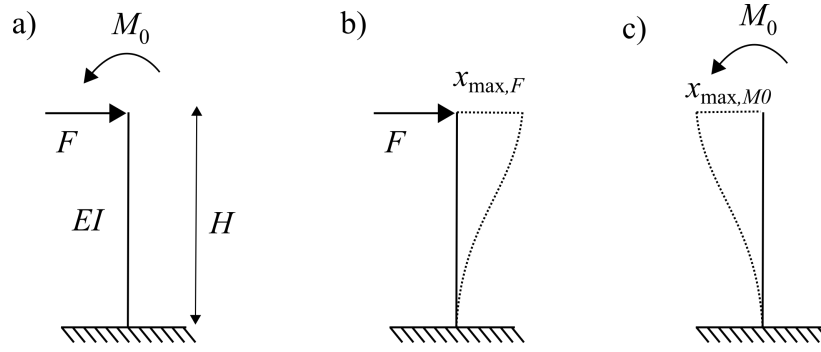

Figure 8.2: Single column subjected to: (a) force and moment; (b) force only; (c) moment only.

Since the system is linear, we can calculate the effects of F and M_0 separately and then summed them together (superposition principle). The maximum deflection due to F occurs at the top of the column, as shown in figure 8.2 (b), and it is equal to:

$$x_{\max,F} = \frac{FH^3}{3EI} \quad (8.2)$$

while the maximum deflection caused by M_0 (figure 8.2 (c)) is:

$$x_{\max,M0} = \frac{M_0H^2}{2EI} \quad (8.3)$$

The displacements in equation 8.2 and 8.3 were found using engineering tables. The total displacement x at the top of the column is obtained from the sum of the two displacements:

$$x = \frac{FH^3}{3EI} - \frac{M_0H^2}{2EI} \quad (8.4)$$

where the $x_{\max,M0}$ is negative in sign because the displacement caused by M_0 goes in opposite direction to $x_{\max,F}$. Replacing $M_0 = \frac{FH}{2}$ in equation 8.4:

$$x = \frac{FH^3}{3EI} - \frac{FH^3}{4EI} = \frac{FH^3}{12EI} \quad (8.5)$$

Applying Hooke's law:

$$F = k_c x = k_c \frac{FH^3}{12EI} \quad (8.6)$$

where k_c is the stiffness of the column. Therefore:

$$k_c = \frac{12EI}{H^3} \quad (8.7)$$

Since the frame has two columns, the total stiffness of the SDOF system will be:

$$k = \sum_{\text{columns}} k_c = \sum_2 \frac{12EI}{H^3} \quad (8.8)$$

where k is also called *lateral stiffness*. Note that the lateral stiffness of the frame is independent on the length of the bay L and it depends only on the properties of the columns (E , I , and H). It is possible at this point to calculate the natural frequency of the frame:

$$\omega_n = \sqrt{\frac{k}{m}} = \sqrt{\frac{\sum_2 \frac{12EI}{H^3}}{m}} \quad (8.9)$$

If the columns have same properties, equation 8.9 becomes:

$$\omega_n = \sqrt{\frac{k}{m}} = \sqrt{\frac{24EI}{H^3 m}} \quad (8.10)$$

Finally, the response of the system to initial conditions x_0 and v_0 can be obtained:

$$x(t) = x_0 \cos(\omega_n t) + \frac{v_0}{\omega_n} \sin(\omega_n t) \quad (8.11)$$

Example 8.1 Single-story Frame

Let's consider the single-story frame shown in figure 8.1 with mass $m = 0.15 \text{ kip s}^2/\text{ft}$, $L = 12 \text{ ft}$, $EI = 1800 \text{ kip ft}^2$. a) Determine the EOM and the natural period of the frame; b) assume that the moment of inertia of the right column is $2I$. Will the EOM change?

Solution a) :

The frame can be modeled as a single degree of freedom in free vibration. Therefore, the EOM is:

$$m\ddot{x} + kx = 0 \quad (8.12)$$

The lateral stiffness of the system is:

$$k = \sum_{\text{columns}} k_c = \sum_2 \frac{12EI}{H^3} = \frac{24EI}{H^3} \quad (8.13)$$

Thus, the natural frequency and period are:

$$\omega_n = \sqrt{\frac{k}{m}} = \sqrt{\frac{24EI}{mH^3}} = \sqrt{\frac{1800}{0.15 \cdot 12^3}} = 12.91 \frac{\text{rad}}{\text{s}} \quad (8.14)$$

$$T_n = \frac{2\pi}{\omega_n} = 0.48\text{s} \quad (8.15)$$

Solution b) :

The EOM won't change, but the lateral stiffness of the system will be:

$$k = \sum_{\text{columns}} k_c = \frac{12EI}{H^3} + \frac{24EI}{H^3} = \frac{36EI}{H^3} \quad (8.16)$$

The same principle can be applied to a single-story frame with damping ratio $\zeta \neq 0$. In this case, the displacement of the frame will be given by:

$$x(t) = e^{(-\zeta \omega_n t)} \left(\frac{(v_0 + x_0) \omega_n}{\omega_d} \cos(\omega_d t) + x_0 \sin(\omega_d t) \right) \quad (8.17)$$

where ω_d is the damped natural frequency of the system:

$$\omega_d = \omega_n \sqrt{1 - \zeta^2} \quad (8.18)$$

8.2 Duhamel's Integral

In Chapter 4, the frequency response method was used to solve the EOM of an SDOF system subjected to an arbitrary force. Here, an alternative method widely employed in structural dynamics to find the solution of the EOM is presented. This method exploits a specific integral, named Duhamel's integral.

Let's consider an underdamped SDOF system subjected to an arbitrary force $F(t)$. The EOM is:

$$m\ddot{x} + c\dot{x} + kx = F(t) \quad (8.19)$$

Let's assume that the system is at rest: $x(0) = 0$ and $\dot{x} = 0$. The assumption underlying Duhamel's integral method is that a generic force $F(t)$ can be expressed as a sequence of impulses of very small duration and the response of the system as the sum of the response to individual unit impulses.

An impulsive force can be defined as a very large force applied in a very short time interval. figure 8.3 (a) shows an impulsive force $F(t) = \frac{1}{\varepsilon}$ applied at time $t = \tau$. Assuming to apply an impulsive force to a generic mass m and applying Newton's second law:

$$m\ddot{x} = F(t) \quad (8.20)$$

and integrating both sides between two generic time instants t_1 and t_2 yields:

$$\int_{t_1}^{t_2} F(t) dt = m(\dot{x}_1 - \dot{x}_2) \quad (8.21)$$

where the left-hand side of the equation represents the magnitude of the force and the right-hand side the change in momentum.

In the limit case in which ε tends to 0, $F(t)$ tends to 1 and the impulsive force is called *unit impulse*. In the case of a unit impulse, $\int_{t_1}^{t_2} F(t) dt = 1$ and t_1 tends to t_2 . Therefore, the velocity of the mass can be found as:

$$\dot{x}(\tau) = \frac{1}{m} \quad (8.22)$$

A similar concept applies to an SDOF system. Since the impulse is applied in a very short time interval, the spring and the damper do not have the time to react. When we apply a unit impulse to an underdamped SDOF, the system will start vibrating with velocity $\dot{x}(\tau)$ given by equation 8.22 and displacement $x(\tau) = 0$. The response of the system is given by the following equation:

$$x(t) = h(t - \tau) = \frac{1}{m\omega_d} e^{-\zeta \omega_n (t - \tau)} \sin(\omega_d (t - \tau)) \quad (8.23)$$

where τ is the time instant at which the impulse is applied.

NOTE

The Dirac delta function $\delta(t - \tau)$ mathematically defines a unit impulse centered at $t = \tau$.

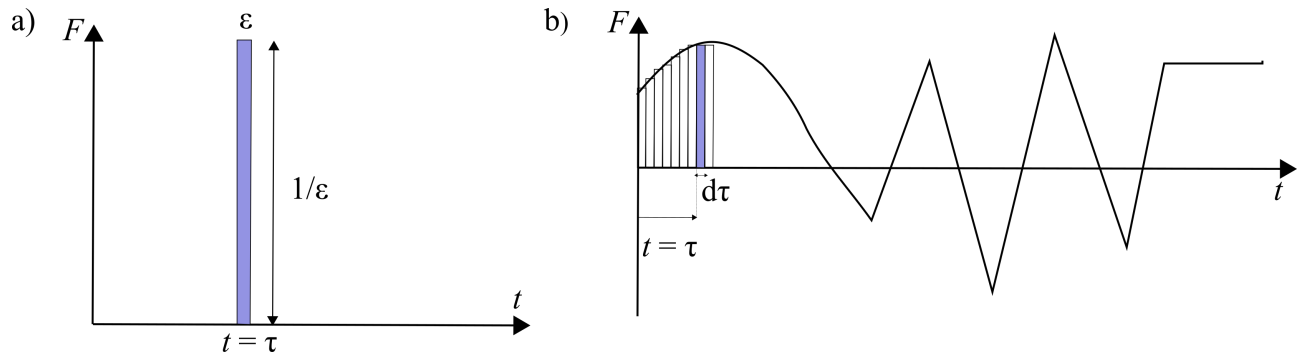

Figure 8.3: (a) Impulsive force; (b) arbitrary force decomposed in a series of impulses.

Let's now consider a force $F(t)$ varying arbitrarily with time. As shown in figure 8.3 (b), $F(t)$ can be represented as a sequence of infinitesimally short impulses. The response of a linear system to $F(t)$ can be therefore expressed as the response to a series impulses, following:

$$x(t) = \int_0^t p(\tau)h(t - \tau)d\tau \quad (8.24)$$

where $h(t - \tau)$ is the response to a unit impulse and $p(\tau)$ is the magnitude of the actual impulse. For the case of an underdamped SDOF system, equation 8.24 can be re-written as:

$$x(t) = \frac{1}{m\omega_d} \int_0^t p(\tau)e^{-\zeta\omega_n(t-\tau)} \sin(\omega_d(t - \tau))d\tau \quad (8.25)$$

equation 8.25 represents the *Duhamel's integral*.

Similarly, the response of an undamped SDOF system to an arbitrary force can be expressed through the Duhamel's integral as:

$$x(t) = \frac{1}{m\omega_n} \int_0^t p(\tau)\sin(\omega_n(t - \tau))d\tau \quad (8.26)$$

If $F(t)$ is characterized by a simple function, Duhamel's integral can be evaluated in closed form. If the equation of $F(t)$ is complicated, Duhamel's integral can be solved with numerical methods. Equation 8.25 and 8.26 apply when the initial conditions are zero (the system is at rest). If the initial conditions are different than zero, we need to add the free vibration response of the system to equation 8.25 and (8.26), respectively.

Example 8.2 Solving for Response due to Step Function Loading

Let's consider an undamped SDOF system subjected to a step function force with constant amplitude F_0 , as schematically represented in figure 8.4. Assume that the system is at rest (initial conditions: $x(0) = \dot{x}(0) = 0$) and compute the system response $x(t)$.

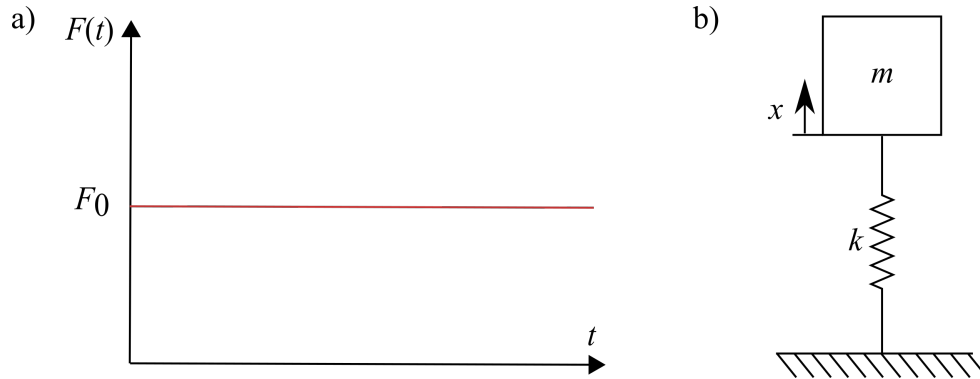

Figure 8.4: (a) Step function force; (b) undamped SDOF system.

Solution:

The system is undamped, therefore we can use the Duhamel's integral in equation 8.26 to find $x(t)$:

$$x(t) = \frac{1}{m\omega_n} \int_0^t F_0 \sin(\omega_n(t - \tau)) d\tau \quad (8.27)$$

Considering that F_0 is constant:

$$x(t) = \frac{F_0}{m\omega_n} \left[\frac{\cos(\omega_n(t - \tau))}{\omega_n} \right]_0^t = \frac{F_0}{m\omega_n^2} [1 - \cos(\omega_n t)] \quad (8.28)$$

Reminding that $\omega_n^2 = k/m$, $x(t)$ becomes:

$$x(t) = \frac{F_0}{k} [1 - \cos(\omega_n t)] \quad (8.29)$$

where $\frac{F_0}{k}$ is the displacement that the system would undergo if the force F_0 was applied statically. In the case of underdamped SDOF system, the response becomes:

$$x(t) = \frac{F_0}{k} \left[1 - e^{-\zeta\omega_n t} \left(\cos(\omega_d t) + \frac{\zeta}{\sqrt{1 - \zeta^2}} \sin(\omega_d t) \right) \right] \quad (8.30)$$

8.3 Two-story frame

The concepts discussed in Sec. 1 can be extended to the 2-story frame represented in figure 8.5. In fact, a 2-story frame can be modeled as a 2-DOF system under the following assumptions:

- shear building: flexible columns ($EI \neq 0$), beam infinitely rigid ($EI_b = \infty$), axial deformations of beams and columns negligible ($EA = 0$);
- lumped mass system: floor-mass concentrated at the floor level.

Under such assumptions and free vibrations, we expect that the building moves following the deformed shape reported in figure 8.5 (dotted line). Let's call the degrees of freedom of the frame $x_1(t)$ and $x_2(t)$.

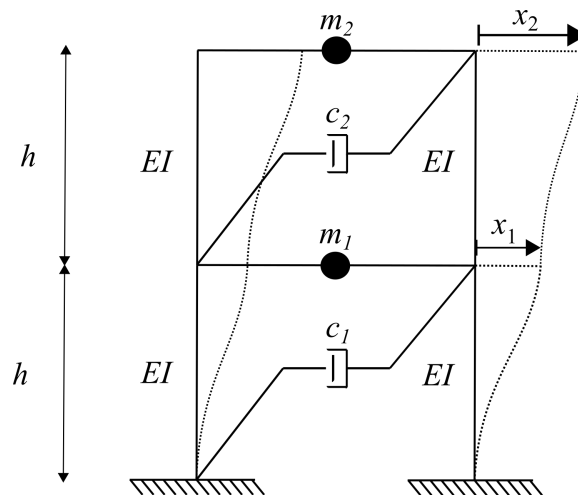

Figure 8.5: 2-story frame with lumped masses.

The forces acting on the 2-DOF system are reported in figure 8.6. It follows that the equation of motion of the two masses are:

$$\begin{aligned} m_1 \ddot{x}_1 + k_1 x_1 + k_2 (x_2 - x_1) + c_1 \dot{x}_1 + c_2 (\dot{x}_2 - \dot{x}_1) &= 0 \\ m_2 \ddot{x}_2 - k_2 (x_2 - x_1) - c_2 (\dot{x}_2 - \dot{x}_1) &= 0 \end{aligned} \quad (8.31)$$

In matrix notation, these two equations become:

$$\begin{bmatrix} m_1 & 0 \\ 0 & m_2 \end{bmatrix} \begin{bmatrix} \ddot{x}_1 \\ \ddot{x}_2 \end{bmatrix} + \begin{bmatrix} k_1 + k_2 & -k_2 \\ -k_2 & k_2 \end{bmatrix} \begin{bmatrix} x_1 \\ x_2 \end{bmatrix} + \begin{bmatrix} c_1 + c_2 & -c_2 \\ -c_2 & c_2 \end{bmatrix} \begin{bmatrix} \dot{x}_1 \\ \dot{x}_2 \end{bmatrix} = \begin{bmatrix} 0 \\ 0 \end{bmatrix} \quad (8.32)$$

where we can define the mass matrix M as:

$$M = \begin{bmatrix} m_1 & 0 \\ 0 & m_2 \end{bmatrix} \quad (8.33)$$

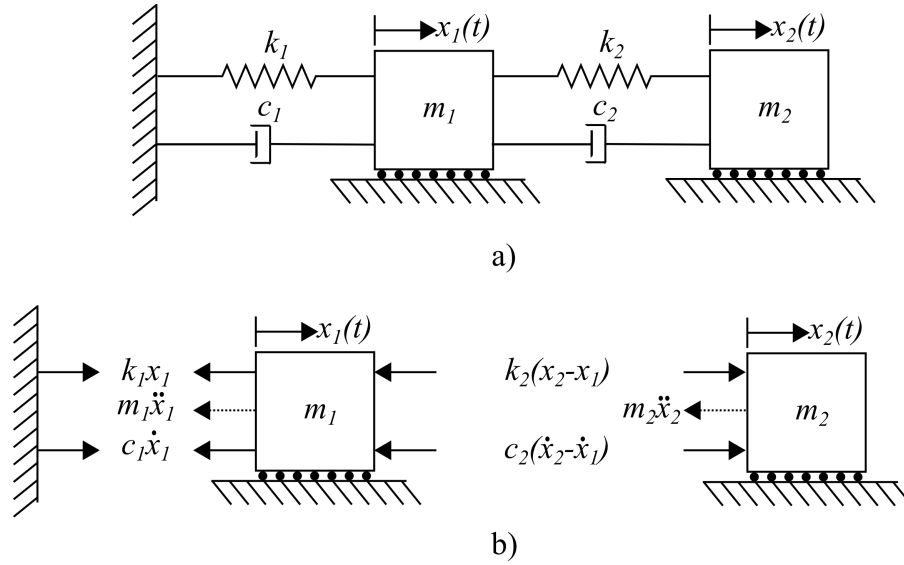

Figure 8.6: (a) 2-DOF system used to model the 2-story frame; (b) free body diagram of the two masses.

the stiffness matrix K as:

$$K = \begin{bmatrix} k_1 + k_2 & -k_2 \\ -k_2 & k_2 \end{bmatrix} \quad (8.34)$$

and the damping matrix C as:

$$C = \begin{bmatrix} c_1 + c_2 & -c_2 \\ -c_2 & c_2 \end{bmatrix} \quad (8.35)$$

While mass and damping of a frame are usually given, the stiffness values k_1 and k_2 need to be calculated as a function of the columns properties (EI) and geometry (h). As demonstrated in Sec. 1, the stiffness of a column with clamped ends can be determined as:

$$k_c = \frac{12EI}{h^3} \quad (8.36)$$

The lateral stiffness of each floor can be computed as the sum of the stiffness of the columns at that floor:

$$k = \sum_{\text{columns}} k_c = \sum_2 \frac{12EI}{h^3} \quad (8.37)$$

Therefore, for the frame in figure 8.5, the stiffness values are:

$$k_1 = k_2 = \frac{24EI}{h^3} \quad (8.38)$$

The solution of the EOM in Eq.(8.32) was derived in Chapter 5 and can be summarized as:

$$\begin{bmatrix} x_1(t) \\ x_2(t) \end{bmatrix} = [\mathbf{u}_1 \quad \mathbf{u}_2] \begin{bmatrix} A_1 \sin(\omega_1 t + \phi_1) \\ A_2 \sin(\omega_2 t + \phi_2) \end{bmatrix}, \quad \omega_1 \text{ or } \omega_2 \neq 0 \quad (8.39)$$

where \mathbf{u}_1 and \mathbf{u}_2 are eigenvectors (or mode shapes), ω_1 and ω_2 are the natural frequency of vibration, ϕ_1 , ϕ_2 , A_1 , and A_2 are constants that can be found based on the initial conditions (see Chapter 5 for more details).

Example 8.3 Finding the Structural Response of a Two Story Building

Consider the frame in figure 8.7. Determine the natural frequency of vibration and mode shapes of the system.

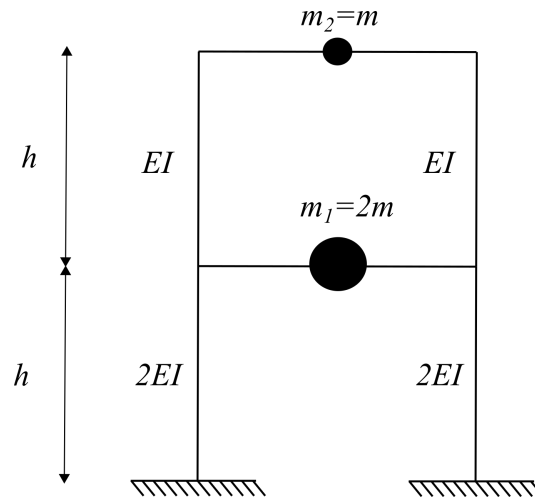

Figure 8.7: Example of a 2-story frame with floors with different dynamic properties.

Solution:

Assumption: the frame can be modeled as a shear building with mass lumped at the floor levels. The lateral stiffness at the first floor is:

$$k_1 = 2 \frac{12(2EI)}{h^3} = \frac{48EI}{h^3} \quad (8.40)$$

The lateral stiffness at the second floor is:

$$k_2 = 2 \frac{12(EI)}{h^3} = \frac{24EI}{h^3} \quad (8.41)$$

Therefore, the stiffness matrix can be written as:

$$K = \begin{bmatrix} \frac{48EI}{h^3} + \frac{24EI}{h^3} & -\frac{24EI}{h^3} \\ -\frac{24EI}{h^3} & \frac{24EI}{h^3} \end{bmatrix} = \frac{24EI}{h^3} \begin{bmatrix} 3 & -1 \\ -1 & 1 \end{bmatrix} \quad (8.42)$$

The EOM of the system is:

$$\begin{bmatrix} 2m & 0 \\ 0 & m \end{bmatrix} \begin{bmatrix} \ddot{x}_1 \\ \ddot{x}_2 \end{bmatrix} + \frac{24EI}{h^3} \begin{bmatrix} 3 & -1 \\ -1 & 1 \end{bmatrix} \begin{bmatrix} x_1 \\ x_2 \end{bmatrix} = \begin{bmatrix} p_1 \\ p_2 \end{bmatrix} \quad (8.43)$$

In order to determine the natural frequency of vibration and the mode shapes of the system, we need to solve the characteristic equation:

$$\det(-\omega^2 M + K) = 0 \quad (8.44)$$

leading to:

$$2m^2 \omega^4 + 5km\omega^2 + 2k = 0 \quad (8.45)$$

This equation has two solutions:

$$\omega_1^2 = \frac{k}{2m} \quad (8.46)$$

$$\omega_2^2 = \frac{2k}{m} \quad (8.47)$$

Therefore, the two natural frequencies of vibration of the system are:

$$\omega_1 = \sqrt{\frac{k}{2m}} \quad (8.48)$$

$$\omega_2 = \sqrt{\frac{2k}{m}} \quad (8.49)$$

where $k = \frac{24EI}{h^3}$. The mode shapes of the frame can be found by solving the following equation:

$$(-\omega_1^2 M + K)\mathbf{u}_1 = 0 \quad (8.50)$$

Replacing mass and stiffness matrix the equation becomes:

$$\left(-\frac{k}{2m} \begin{bmatrix} 2m & 0 \\ 0 & m \end{bmatrix} + k \begin{bmatrix} 3 & -1 \\ -1 & 1 \end{bmatrix} \right) \begin{bmatrix} u_{11} \\ u_{21} \end{bmatrix} = \begin{bmatrix} 0 \\ 0 \end{bmatrix} \quad (8.51)$$

simplified to

$$\begin{bmatrix} 2k & -k \\ -k & \frac{k}{2} \end{bmatrix} \begin{bmatrix} u_{11} \\ u_{21} \end{bmatrix} = \begin{bmatrix} 0 \\ 0 \end{bmatrix} \quad (8.52)$$

leading to two equations:

$$2ku_{11} - ku_{21} = 0, \text{ and } -ku_{11} + \frac{k}{2}u_{21} = 0 \quad (8.53)$$

It follows that:

$$2u_{11} = u_{21}, \text{ and } u_{11} = \frac{1}{2}u_{21} \quad (8.54)$$

To obtain a numerical value, we arbitrarily assign a value to one of the elements. Here, let $u_{21} = 1$ so let $u_{11} = 1/2$. Therefore,

$$\mathbf{u}_1 = \begin{bmatrix} \frac{1}{2} \\ 1 \end{bmatrix} \quad (8.55)$$

Similarly, \mathbf{u}_2 can be obtained by solving the following equation:

$$(-\omega_2^2 M + K)\mathbf{u}_2 = 0 \quad (8.56)$$

leading to:

$$\mathbf{u}_2 = \begin{bmatrix} -1 \\ 1 \end{bmatrix} \quad (8.57)$$

Figure 8.8 represents the two-mode shapes of the building.

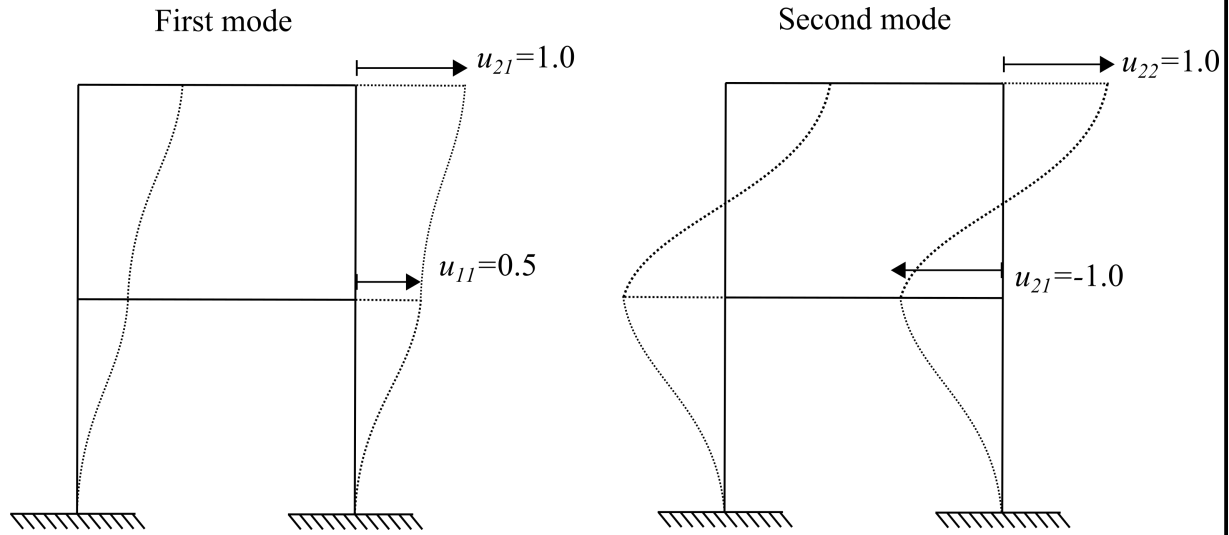

Figure 8.8: Mode shapes of the 2-story frame.

The temporal response of the system is given by:

$$\begin{bmatrix} x_1(t) \\ x_2(t) \end{bmatrix} = [\mathbf{u}_1 \quad \mathbf{u}_2] \begin{bmatrix} A_1 \sin(\omega_1 t + \phi_1) \\ A_2 \sin(\omega_2 t + \phi_2) \end{bmatrix}, \quad \omega_1 \text{ or } \omega_2 \neq 0 \quad (8.58)$$

where $\mathbf{u} = [\mathbf{u}_1, \mathbf{u}_2]$ is the time invariant part of the equation.